Charles Large

SOFAS

Antonio Citterio



Description

A very comfortable seat, the sofa is a welcoming shelter to lie down in. This is the new concept of the Charles system by Antonio Citterio, which has become in time a classical element of interior design, a huge market success since its creation in 1997. A wide depth reshapes its line.

Technical information

Internal frame:

tubular steel and steel profiles

Internal frame upholstery:

Bayfit® (Bayer®) flexible cold shaped polyurethane foam, polyester fibre cover

Seat cushion upholstery (home):

shaped polyurethane of different density, sterilized down, polyester fibre cover

Seat cushion upholstery (public spaces):

shaped polyurethane of different density, polyester fibre, polyester fibre cover

Back cushion (CH48_C-CH72_C):

upholstery : polyester fibre, typology : box style

Feet:

bronzed nickel painted, bright brushed or painted black chrome die-cast aluminium

Ferrules:

thermoplastic material

Cover:

fabric or leather

Technical drawings

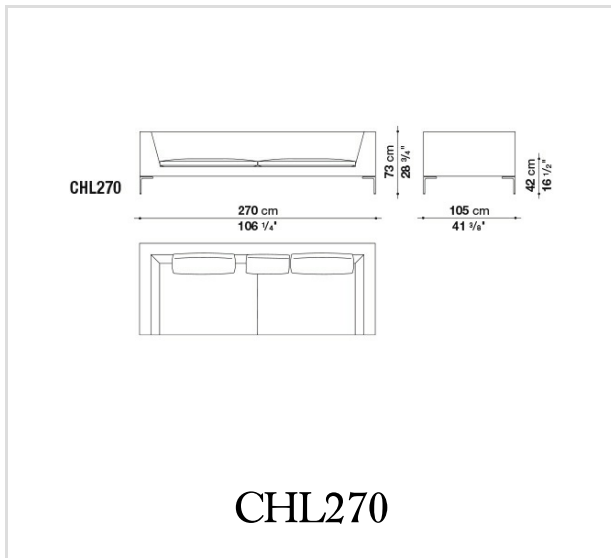

CHL270

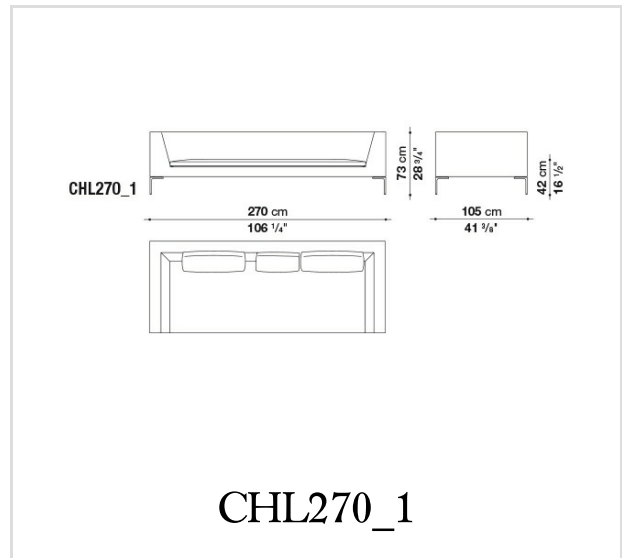

CHL270_1

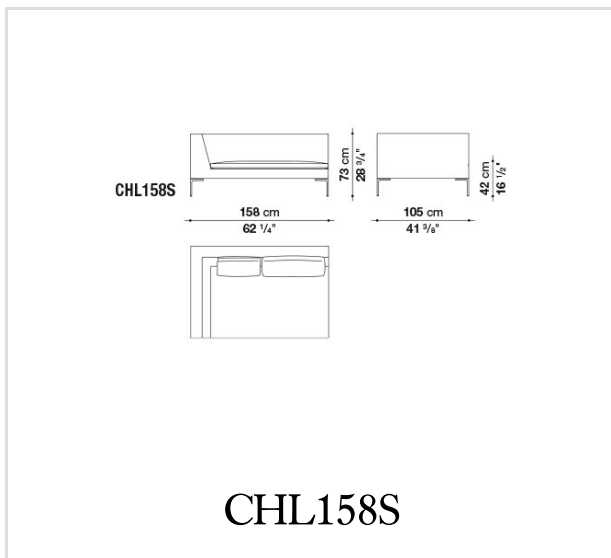

CHL158S

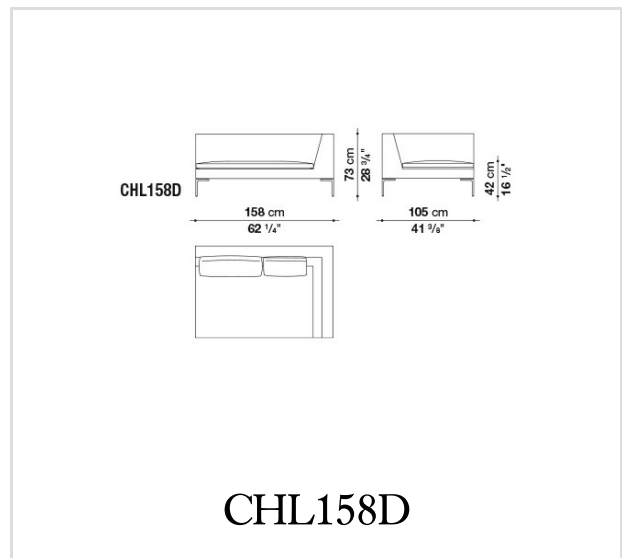

CHL158D

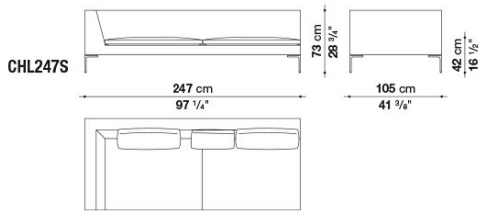

CHL247S

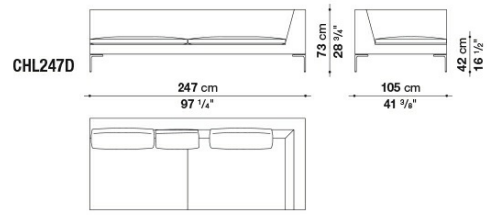

CHL247D

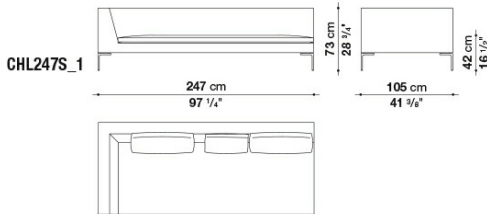

CHL247S_1

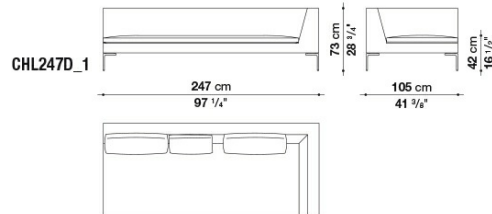

CHL247D_1

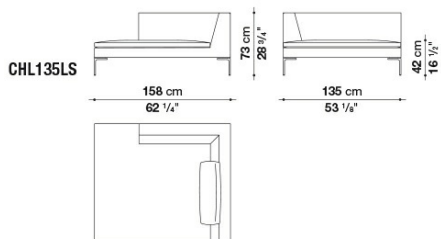

CHL135LS

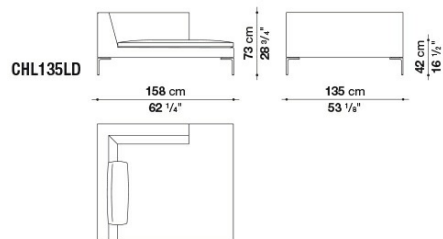

CHL135LD

CHL247LS_1

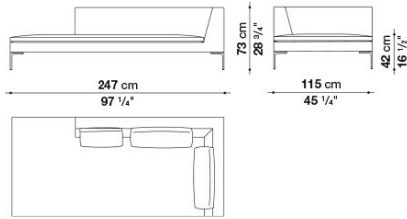

CHL247LS_1

CHL247LD_1

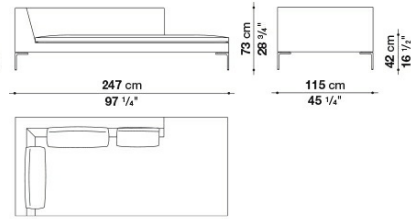

CHL247LD_1

B&B Italia reserves the right to make technological and aesthetic improvements to its models, including changes to the sizes and materials, without notice. The technical drawings do not define the details of the product. The measurements shown are indicative and may undergo changes. In particular, the dimensions relevant to the padded parts are subject to usage tolerances over time caused by the normal adjustment of the padding. For the specific information, please contact the dealer closest to you.