

---

# Mirto Indoor

CHAIRS

*Antonio Citterio*



## Description

The classic director's chair (a fixed variant that comes with or without arms and a folding version) is reinvented with contemporary sophistication and meticulous attention to detail and proportions, not to mention the grain of leather used on the seat and the back. The structure of the chair is available in light or dark tones, whereas the leather is available in natural or black. Different shades are able to offer different images for a different kind of feel.

---

## Technical information

### Frame:

black painted, pewter painted or painted black chrome die-cast aluminium

### Internal components:

thermoplastic material and steel

### Ferrules:

thermoplastic elastomer

### Cover:

natural, black, dark brown, bordeaux, bottle green or mud green embossed thick leather

# Technical drawings

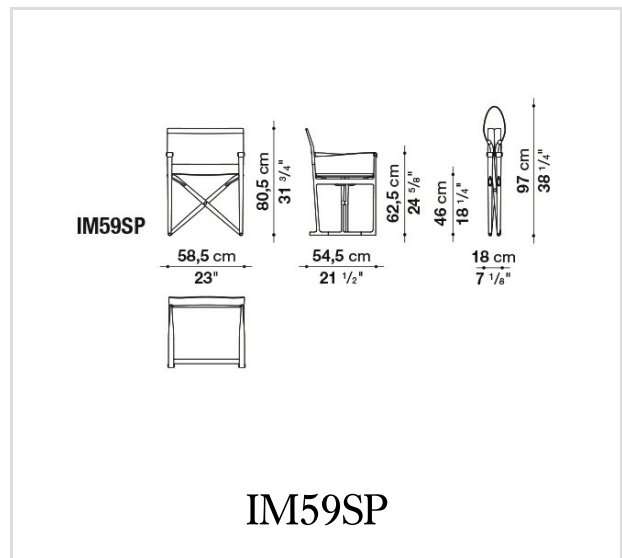
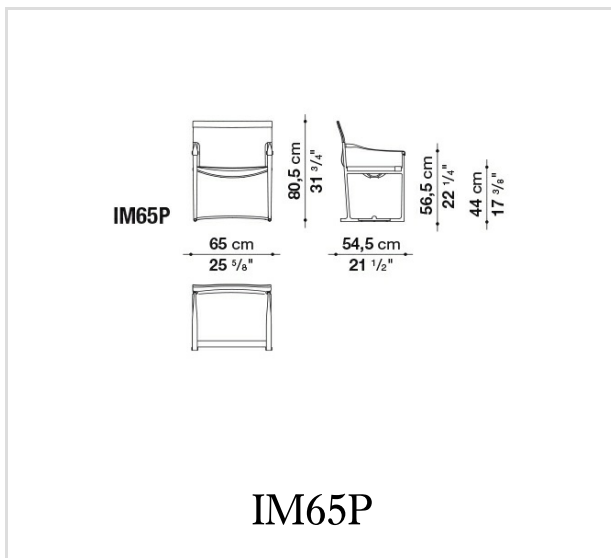
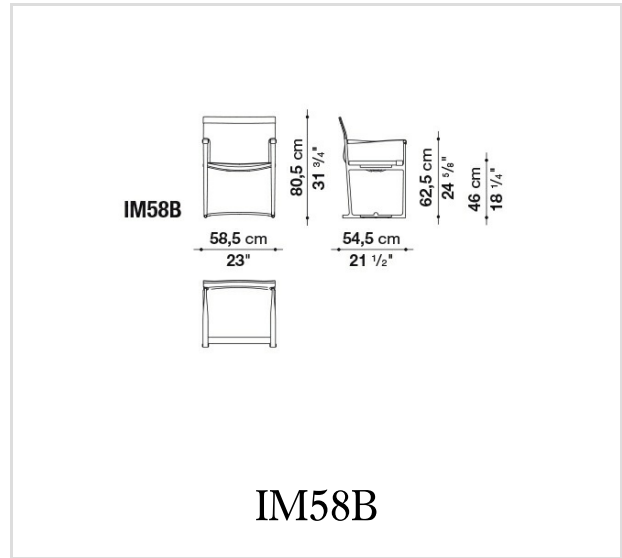
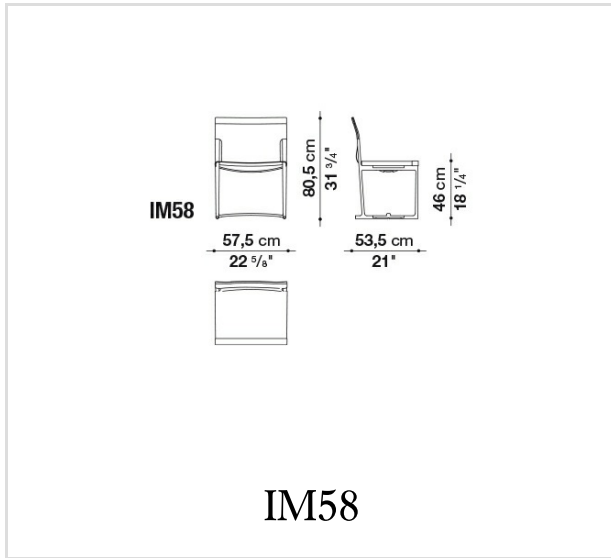

B&B Italia reserves the right to make technological and aesthetic improvements to its models, including changes to the sizes and materials, without notice. The technical drawings do not define the details of the product. The measurements shown are indicative and may undergo changes. In particular, the dimensions relevant to the padded parts are subject to usage tolerances over time caused by the normal adjustment of the padding. For the specific information, please contact the dealer closest to you.