

TECHNICAL CATALOGUE

Collezione Home — HOME COLLECTION



Indice prodotti / Product index

01 Tavoli /

Table

- [8 Adam](#)
- [10 Clemo-T](#)
- [12 Dolm](#)
- [14 Dolm Plus](#)
- [16 Eros](#)
- [18 Eyl](#)
- [20 Haumea-T](#)
- [24 Maat](#)
- [28 Manto](#)
- [32 Manto Oval](#)
- [34 Oto](#)
- [36 Oto Big](#)
- [38 Oto Medium](#)
- [40 Platium](#)
- [42 Platium Round](#)
- [44 Platium System](#)
- [46 Platium W](#)
- [48 Prism](#)
- [50 Shiro](#)
- [52 Simpòdio](#)
- [54 Simpòdio System](#)
- [56 Yol](#)
- [58 Yol Sect](#)
- [62 Zen](#)
- [64 Zen Black](#)
- [66 Lazy Susan](#)

- [68 Informazioni tecniche/
Technical informations](#)

02 Sedute /

Seatings

- [86 0414](#)
- [88 0419](#)
- [90 Akiko](#)
- [92 Jackie](#)
- [94 Janette](#)
- [96 Keyko](#)
- [98 Livrette](#)
- [100 Thea](#)
- [102 Thea Queen](#)

- [104 Informazioni tecniche/
Technical informations](#)

03 Carrelli /

Trolleys

- [114 Mister](#)
- [116 Riki](#)

- [118 Informazioni tecniche/
Technical informations](#)

04 Panche e Pouf /

Benches and Pouffe

- [124 Audrey Pouf](#)
- [126 Cloud Pouf](#)
- [128 Lilas Bench](#)
- [130 Lou](#)
- [132 Oly](#)
- [134 Stami Bench](#)
- [136 Stami DayBed](#)
- [138 Stami Pouf](#)
- [140 Twelve DayBed](#)

- [142 Informazioni tecniche/
Technical informations](#)

05 Divani e poltrone /

Sofas and armchairs

- [152 0417](#)
- [154 Akiko Lounge](#)
- [156 Audrey](#)
- [158 Audrey Motion](#)
- [160 Audrey Poltrona](#)
- [162 Cloud](#)
- [164 Cloud Infinity](#)
- [166 Cloud Poltrona](#)
- [168 Elissa](#)
- [170 Elissa Sectional](#)
- [174 Fiona](#)
- [176 Fiona Soft](#)
- [178 First](#)
- [180 First Modulare](#)
- [182 First Poltrona & Pouf](#)
- [184 Lilas](#)
- [186 Lilas Mosaïque](#)
- [188 Livre](#)
- [190 Sophie](#)
- [192 Sophie Sofa](#)
- [194 Stami Lounge](#)

- [196 Informazioni tecniche/
Technical informations](#)

06 Tavolini /

Coffee Tables

- [226 1968](#)
- [228 Chantal](#)
- [230 Clemo](#)
- [234 Connection](#)
- [236 Cookies](#)
- [238 Cookies Circle](#)
- [240 Dama](#)
- [242 Drummers](#)
- [244 Fante](#)
- [246 Faraday](#)
- [248 George 1](#)
- [250 George 2](#)
- [252 Golden Moon](#)
- [254 Gong](#)
- [256 Haumea](#)
- [260 Monete](#)
- [264 Nori](#)
- [266 Nox](#)
- [268 Oto Mini](#)
- [270 Prism Low](#)
- [272 Raj 1](#)
- [274 Raj 2](#)
- [276 Raj 3](#)
- [278 Raj 6](#)
- [280 Re-verre](#)
- [282 Selce](#)
- [284 Sensei](#)
- [286 Sir T 32/Sir T 32 C](#)
- [288 T33](#)
- [290 T35 R](#)
- [292 T 35 Trio](#)
- [294 Tetris](#)
- [296 Twelve](#)
- [298 Zen Black Low](#)
- [300 Zen Low](#)

- [302 Informazioni tecniche/
Technical informations](#)

Indice prodotti / Product index

07 Consolle / Consoles

322 [Athus Console](#)
324 [Dolm Console](#)
326 [Hanami](#)
328 [Sensei Console](#)
330 [Tama Console](#)

332 [Informazioni tecniche/
Technical informations](#)

08 Contenitori / Storage Units

338 [5th Avenue](#)
340 [5th Avenue Crédence](#)
342 [Athus](#)
344 [Diedro](#)
346 [Gastone](#)
348 [Gastone Low](#)
350 [Hide&Seek](#)
354 [Kumi Credenza](#)
356 [Pandora](#)
358 [Pandora Cashmere](#)
360 [Pandora Craquelé](#)
362 [Pandora Light](#)
364 [Soda](#)
368 [Tama](#)
370 [Tama Crédence](#)
372 [Tama Vitrine](#)

374 [Informazioni tecniche/
Technical informations](#)

09 Librerie e boiserie / Shelving systems and boiserie

390 [Brera](#)
392 [Brera 23](#)
394 [Drizzle](#)
396 [Isola](#)
400 [Navigli](#)
402 [Pleiadi](#)
404 [Prism Divider](#)
408 [Roundcut](#)
410 [Syil](#)
412 [Tortona](#)

414 [Informazioni tecniche/
Technical informations](#)

Indice prodotti / Product index

13 Divisori / Dividers

496 [Chloé](#)
498 [Shield](#)

500 [Informazioni tecniche/
Technical informations](#)

14 Lampade / Lightings

506 [Bolle](#)
508 [Bolle Aria](#)
510 [Bolle Cielo](#)
512 [Bolle Orizzontale](#)
514 [Bolle Sola](#)
516 [Bolle Tavolo 1](#)
518 [Bolle Tavolo 3](#)
520 [Bolle Tela](#)
522 [Bolle Terra](#)
524 [Bolle Verticale](#)
526 [Bonfire](#)
528 [Diantha](#)
530 [Diantha Terra](#)
532 [Epsilon](#)
534 [Epsilon Sola](#)
536 [Eris](#)
538 [Jolie](#)
540 [Jolie Applique](#)
542 [Key-to-Heaven](#)
544 [Key-to-Heaven Fix](#)
546 [Narghilè](#)
548 [Ori](#)
550 [Spectrum](#)

552 [Informazioni tecniche/
Technical informations](#)

15 Specchi / Mirrors

568 [Black&White Beats](#)
570 [Cubista](#)
572 [Dream](#)
574 [Garda](#)
576 [Gemma](#)
578 [Keplero](#)
580 [Leaf](#)
582 [Lebel 10](#)
584 [Niagara](#)
586 [Odette](#)
588 [Selene Mirror](#)
590 [Soft](#)
592 [Sole](#)
594 [Zed](#)
596 [Zeiss Mirror](#)

598 [Informazioni tecniche/
Technical informations](#)

10 Letti / Beds

432 [Eve](#)
434 [Lilas Bed](#)
436 [Xeni](#)
438 [Yuki](#)

440 [Informazioni tecniche/
Technical informations](#)

11 Complementi notte / Night accessories

450 [Duale](#)
452 [Holly Comò](#)
454 [Holly Comodino](#)
456 [Kumi Comò](#)
458 [Stami Night](#)
460 [Twelve C](#)

462 [Informazioni tecniche/
Technical informations](#)

12 Scrittoi e Vanity / Desks and Vanity

470 [Lui](#)
472 [President Junior/President Senior](#)
474 [President Junior/President Senior 50th](#)
476 [Prism Desk](#)
478 [Selene](#)
480 [Soho](#)
482 [Stami](#)
484 [Tama Secrétaire](#)
486 [Venere](#)

488 [Informazioni tecniche/
Technical informations](#)

16 Elementi decorativi / Decorative elements

608 [Lazy Susan](#)
610 [Leaf Sculpture](#)

612 [Informazioni tecniche/
Technical informations](#)

17 Tappeti / Rugs

618 [Metaphores](#)
622 [Resia](#)
624 [Ruggy](#)

626 [Informazioni tecniche/
Technical informations](#)

18 Accessori / Accessories

634 [Vase 1968](#)
636 [Candle Holder](#)
637 [Candle Holder Hexagonal](#)
638 [Desk Card Holder](#)
640 [Desk Set](#)
642 [Flabello](#)
644 [Folded Tray](#)
646 [Moonlight](#)
647 [Mouse Pad](#)
648 [Odette Tray](#)
650 [Paperweight](#)
652 [Pleiadi](#)
654 [Segno](#)
655 [Teddy](#)
656 [Tic Tac 14](#)
658 [Tip Tap Toe](#)

660 [Informazioni tecniche/
Technical informations](#)

01 Tavoli /

Table

8	Adam
10	Clemo-T
12	Dolm
14	Dolm Plus
16	Eros
18	Eyl
20	Haumea-T
24	Maat
28	Manto
32	Manto Oval
34	Oto
36	Oto Big
38	Oto Medium
40	Platium
42	Platium Round
44	Platium System
46	Platium W
48	Prism
50	Shiro
52	Simpòdio
54	Simpòdio System
56	Yol
58	Yol Sect
62	Zen
64	Zen Black
66	Lazy Susan
68	Informazioni tecniche/ Technical informations

Adam

Studio G&R / 1971

Tavolo in cristallo trasparente. Basamenti in cristallo 15mm, curvati a fuoco e molati a mano. Parti metalliche cromate. Disponibile anche senza parti metalliche (altezza finita: 72 cm). Su richiesta si realizzano piani con dimensioni speciali.

Table in transparent glass. Bases in 15mm glass curved by fire and hand bevelled. Chromed metal clips. Also available without metal parts (total height: 72 cm). Customised sizes for the top on request.

! Per piani di dimensioni superiori a 260cm sono previste 4 basi.
Grazie al peso del cristallo il piano viene solo appoggiato sulla base e non necessita di fissaggio.

! For glass top larger than 260cm, 4 bases are provided.
Thanks to the weight of the glass, the top is only placed on the base and does not need to be fixed.



Cm	Inches
○ Ø 130 x 74 Ø 150 x 74	Ø 51¼" x 29¼" Ø 59¼" x 29¼"
○ 160 x 130 x 74 180 x 130 x 74 210 x 130 x 74	63" x 51¼" x 29¼" 71" x 51¼" x 29¼" 82¾" x 51¼" x 29¼"
○ 210 x 120 x 74 240 x 120 x 74 260 x 120 x 74	82¾" x 47¼" x 29¼" 94½" x 47¼" x 29¼" 102½" x 47¼" x 29¼"
○ Piano spessore 19mm 280 x 120 x 74 300 x 120 x 74	Top thickness 19mm 110¼" x 47¼" x 29¼" 118¼" x 47¼" x 29¼"

For technical drawing / p. 22

Pricelist 2023 / p. 10

PIANO/TOP



Cristallo trasparente
Transparent glass

PARTI METALLICHE /METAL PARTS



Metallo cromato
Chromed metal



▲ **CLEMO - T**
Marmo Arabescato Orobico Rosso / Parti metalliche in metallo brunito a mano "dark"
Arabescato Orobico Rosso marble / "Dark" hand burnished metal parts

Clema - T

Massimo Castagna / 2022

Tavolo in marmo 20mm Arabescato Orobico Rosso satinato, disponibile anche in Ceppo di Gré® spazzolato oppure in marmo Bianco Carrara Gioia spazzolato. Dettagli in metallo brunito a mano "dark".

Table in 20mm Arabescato Orobico Rosso satin marble. Also available in brushed Ceppo di Gré® or brushed Bianco Carrara Gioia marble. "Dark" hand burnished metal details.

NOTE TECNICHE SUI MATERIALI

CEPPO DI GRÉ® - MARMO | Il marmo è un materiale naturale di origine sedimentaria che può presentare particolarità come venature, lievi irregolarità superficiali, colorazioni differenti e cristallizzazioni. Queste peculiarità sono da attribuirsi alla naturalezza del materiale e non sono da considerarsi difetti ma caratteristiche tipiche del marmo. Ogni prodotto risulterà unico, esclusivo e non replicabile. I nostri marmi vengono trattati con un prodotto idrorepellente che permette una maggiore protezione della superficie stessa, aumentando l'impermeabilità. Questo trattamento non esclude la vulnerabilità del marmo alle sostanze acide.

TECHNICAL INFORMATION ON THE MATERIALS

CEPPO DI GRÉ® - MARBLE | The marble is a natural material of sedimentary origin that can present particularities such as veins, slight surface irregularities, different colors and crystallizations. These peculiarities are to be attributed to the naturalness of the material and are not to be considered defects but typical characteristics of marble. Each product will be unique, exclusive and non-replicable. Our marbles are treated with water-repellent products which affords greater protection to the surface of the marble, improving its impermeability. This treatment doesn't exclude the vulnerability of the marble to acid substances.



Cm

170 x 130 x 74
170 x 170 x 74
260 x 130 x 74
260 x 170 x 74

Inches

67" x 51¼" x 29¼"
67" x 67" x 29¼"
102½" x 51¼" x 29¼"
102½" x 67" x 29¼"

[For technical drawing / p.72](#)

[Pricelist 2023 / p.11](#)
[Homescapes, gentle attitude / pp.15-19](#)

STRUTTURA/STRUCTURE



Marmo Arabescato Orobico Rosso satinato
Arabescato Orobico Rosso satin marble

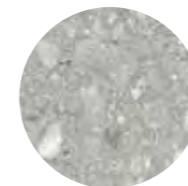

Ceppo di Gré® spazzolato
Brushed Ceppo di Gré®



Marmo Bianco Carrara Gioia spazzolato
Brushed Bianco Carrara Gioia marble

DETTAGLI/DETAILS



Metallo brunito a mano "dark"
"Dark" hand burnished metal



▲ DOLM
Piano in cristallo extralight / Base in cristallo retroverniciato nero brillante
Extralight glass top / Bright black painted glass

Dolm

Oscar e Gabriele Buratti / 2012

Tavolo con piano in cristallo extralight 15mm, retroverniciato solo nella parte centrale nei colori del campionario nella versione brillante. Piano con bisello alternato a 45°. Disponibile anche nella versione con piano non bisellato. Basi in legno rivestito in cristallo 6mm temperato retroverniciato brillante. La retroverniciatura del piano nella parte centrale è realizzabile esclusivamente nella versione brillante.

! La retroverniciatura del piano nella parte centrale è realizzabile esclusivamente nella versione brillante.

L'azienda si riserva di scegliere il colore della trave in metallo coordinandola con la finitura del cristallo.

Grazie al peso del cristallo il piano viene solo appoggiato sulla base e non necessita di fissaggio.

Table with 15mm extralight glass top, painted only in the middle part as per samples in the bright version. 45° alternated bevelled glass top. Also available in the version with not bevelled glass top. Wooden base covered by 6mm tempered bright painted glass. The painting of the glass top in the middle part can only be done in the bright version.

! The painting of the glass top in the middle part can only be done in the bright version.

The company reserves the right to choose the colour of the metal beam, matching it with the glass finish.

Thanks to the weight of the glass, the top is only placed on the base and does not need to be fixed.



Cm

200 x 100 x 74
240 x 100 x 74
280 x 110 x 74
320 x 110 x 74
360 x 110 x 74

Inches

78¾" x 39½" x 29¼"
94½" x 39½" x 29¼"
110¼" x 43½" x 29¼"
126" x 43½" x 29¼"
141¾" x 43½" x 29¼"

For technical drawing / p.72

Pricelist 2023 / p.12

PIANO/TOP



Cristallo extralight
Extralight glass

PARTE CENTRALE PIANO/ MIDDLE PART TOP



Cristallo retroverniciato brillante
nei colori del campionario
Bright painted glass
as per samples

BASE/BASE

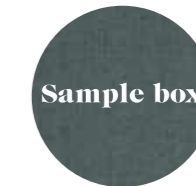

Cristallo retroverniciato brillante
nei colori del campionario
Bright painted glass
as per samples



▲ **DOLM PLUS**
Piano in cristallo verniciato "Cashmere" gold grey
"Cashmere" gold grey painted glass top

Dolm Plus

Oscar e Gabriele Buratti / 2019

Tavolo con piano in cristallo 15mm verniciato nella finitura esclusiva spazzolata "Cashmere" nei colori gold grey o anthracite oppure nella finitura esclusiva bronzo antico o piombo. Importante bisellatura di 60mm su tutti i lati del piano. Basi in legno rivestite in cristallo 6mm verniciato temperato nella stessa finitura del piano.

! L'azienda si riserva di scegliere il colore della trave in metallo coordinandola con la finitura del cristallo.

Grazie al peso del cristallo il piano viene solo appoggiato sulla base e non necessita di fissaggio.

NOTE TECNICHE SUI MATERIALI

CRISTALLO | Le finiture esclusive risultano dalla lavorazione manuale realizzata sul cristallo possono presentare striature e differenze cromatiche. Queste caratteristiche non devono essere considerate difetti ma elementi distintivi del processo artigianale che esaltano la bellezza e la peculiarità del pezzo unico.

Table with 15mm glass top painted with the exclusive "Cashmere" brushed finish in the colours gold grey or anthracite. Also available in the exclusive finish antique bronze or lead. Large bevel of 60mm on all the top edges. Wooden base covered by 6mm tempered painted glass in the same finish of the top.

! The company reserves the right to choose the colour of the metal beam, matching it with the glass finish.

Thanks to the weight of the glass, the top is only placed on the base and does not need to be fixed.

TECHNICAL INFORMATION ON THE MATERIALS

GLASS | Exclusive finishes, resulting from the craftsmanship on the glass, may show streaks and chromatic differences. These characteristics should not be considered imperfections but distinctive evidence of the hand-made process that enhance the beauty and peculiarity of the unique piece.



Cm

200 x 90 x 74
200 x 100 x 74
240 x 90 x 74
240 x 100 x 74
280 x 110 x 74

Inches

78¾" x 35½" x 29¼"
78¾" x 39½" x 29¼"
94½" x 35½" x 29¼"
94½" x 39½" x 29¼"
110¼" x 43½" x 29¼"

For technical drawing / p. 73

Pricelist 2023 / p. 13
Homescapes, sense of materials / p. 51
Homescapes, gentle attitude / p. 45



Cristallo verniciato
"Cashmere" gold grey
"Cashmere" gold grey
painted glass



Cristallo verniciato
"Cashmere" anthracite
"Cashmere" anthracite
painted glass

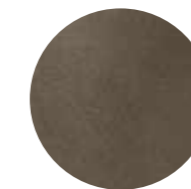

Cristallo verniciato
Bronzo antico
Antique bronze
painted glass

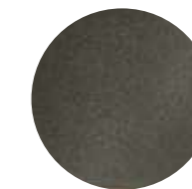

Cristallo verniciato
Piombo
Lead painted glass



▲ **EROS**
Cristallo trasparente / Parti metalliche in ottone cromato
Transparent glass / Chromed brass metal parts

Eros

Pierangelo Gallotti / 1971

Tavolo in cristallo trasparente o extralight. Parti metalliche cromate. Basamento in cristallo temperato 15mm. Per le versioni da 260x120cm il piano è sempre in cristallo trasparente 19mm. Su richiesta si realizzano piani con dimensioni speciali.

Table in transparent or extralight glass. Chromed metal parts. 15mm tempered glass base. For the versions from 260x120cm, the top is always in 19mm transparent glass. Customised sizes for the top on request.

! Per piani di dimensioni superiori a 240cm sono previste 2 basi.

! For glass top larger than 240cm, 2 bases are provided.

Grazie al peso del cristallo il piano viene solo appoggiato sulla base e non necessita di fissaggio.

Thanks to the weight of the glass, the top is only placed on the base and does not need to be fixed.



Cm	Inches
○ Ø 120 x 74	Ø 47 1/4" x 29 1/4"
○ Ø 130 x 74	Ø 51 1/4" x 29 1/4"
○ Ø 140 x 74	Ø 55 1/4" x 29 1/4"
○ Ø 150 x 74	Ø 59 1/4" x 29 1/4"
○ Ø 160 x 74	Ø 63" x 29 1/4"
□ 240 x 120 x 74	94 1/2" x 47 1/4" x 29 1/4"
○ 240 x 120 x 74	94 1/2" x 47 1/4" x 29 1/4"
□ Piano spessore 19mm	Top thickness 19mm
○ 260 x 120 x 74	102 1/2" x 47 1/4" x 29 1/4"
○ 280 x 120 x 74	110 1/4" x 47 1/4" x 29 1/4"
○ 300 x 120 x 74	118 1/4" x 47 1/4" x 29 1/4"
○ 260 x 120 x 74	102 1/2" x 47 1/4" x 29 1/4"
○ 280 x 120 x 74	110 1/4" x 47 1/4" x 29 1/4"
○ 300 x 120 x 74	118 1/4" x 47 1/4" x 29 1/4"

[For technical drawing / p. 73](#)

[Pricelist 2023 / p. 14](#)
[Homescapes, gentle attitude / p. 90](#)

PIANO/TOP



Cristallo trasparente
Transparent glass



Cristallo extralight
Extralight glass

PARTI METALLICHE / METAL PARTS



Metallo cromato
Chromed metal



▲ EYL
Piano in cristallo retroverniciato liquirizia satinato
Satin liquorice painted glass top

Eyl

Oscar e Gabriele Buratti / 2014

Tavolo con piano in cristallo 15mm retroverniciato nei colori del campionario, nella versione brillante o satinata. Piano con bisello 25mm. Base in legno rivestito in cristallo 6mm temperato retroverniciato nella stessa finitura del piano. Parti metalliche in acciaio inox lucido "supermirror". Disponibile anche versione in cristallo verniciato bronzo patinato (escluso per piani cm 280/300).

! Grazie al peso del cristallo il piano viene solo appoggiato sulla base e non necessita di fissaggio.

NOTE TECNICHE SUI MATERIALI

CRISTALLO - BRONZO PATINATO | Le finiture esclusive risultano dalla lavorazione manuale realizzata sul cristallo possono presentare striature e differenze cromatiche. Queste caratteristiche non devono essere considerate difetti ma elementi distintivi del processo artigianale che esaltano la bellezza e la peculiarità del pezzo unico.

Table with 15mm painted glass top as per samples in the bright or satin version. Glass top with 25mm bevelled edge. Wooden base covered by 6mm tempered painted glass in the same finish of the top. "Supermirror" bright stainless steel metal parts. Also available version with patinated bronze painted glass (excluding for glass tops cm 280/300).

! Thanks to the weight of the glass, the top is only placed on the base and does not need to be fixed.

TECHNICAL INFORMATION ON THE MATERIALS

GLASS - PATINATED BRONZE | Exclusive finishes, resulting from the craftsmanship on the glass, may show streaks and chromatic differences. These characteristics should not be considered imperfections but distinctive evidence of the hand-made process that enhance the beauty and peculiarity of the unique piece.



Cm

150 x 150 x 75
210 x 130 x 75
240 x 130 x 75
260 x 130 x 75
280 x 140 x 75
300 x 140 x 75

Inches

59¼" x 59¼" x 29¾"
82¾" x 51¼" x 29¾"
94½" x 51¼" x 29¾"
102½" x 51¼" x 29¾"
110¼" x 55¼" x 29¾"
118¼" x 55¼" x 29¾"

For technical drawing / p.74

Pricelist 2023 / p.15

PIANO/TOP



Cristallo brillante/satinato nei colori del campionario
Bright/satin painted glass version as per samples

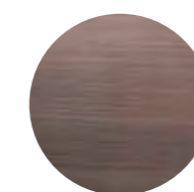

Bronzo patinato
Patinated bronze

PARTI METALLICHE/METAL PARTS



Acciaio inox lucido "supermirror"
"Supermirror" bright stainless steel

Haumea - T

Massimo Castagna / 2016

Tavolo con piano in cristallo trasparente temperato 15mm. Base in frassino tinto nero poro aperto, bianco poro aperto o laccato ruggine. Cilindro centrale in metallo ottonato lucido, brunito a mano, ramato, cromato nero, laccato bianco o nichelato lucido. Ciotola disponibile in ottone lucido, ottone cromato nero, ottone nichelato lucido o ottone laccato bianco. Vassoio amovibile. Disponibile nelle combinazioni sotto elencate. Su richiesta piano in cristallo "grigio Italia" temperato 12mm. Disponibile su richiesta versione lounge cm 65h.

! Per piani di dimensioni superiori a 260cm sono previste due basi.

Versione con due basi: grazie al peso del cristallo il piano viene solo appoggiato sulla base e non necessita di fissaggio.

NOTE TECNICHE SUI MATERIALI

OTTONE BRUNITO A MANO | L'ottone brunito a mano è ottenuto da un processo di ossidazione naturale eseguito manualmente. Il risultato di questa lavorazione è un prodotto che può presentare macchie e variazioni di colore che non sono da considerarsi imperfezioni ma caratteristiche che conferiscono ad ogni pezzo una particolare unicità, rendendolo esclusivo.

Table with 15mm transparent tempered glass top. Black or white open pore stained ash or rust lacquered wooden base. Central cylinder in bright brass-plated, hand burnished, copper-plated, black chromed, white lacquered or bright nickel-plated metal. Bowl available in bright brass, black chromed brass, bright nickel-plated brass or white lacquered brass. Removable tray. Available in the combinations as per our list below. 12mm smoked "grigio Italia" tempered glass top, on request. Lounge version height cm 65, available on request.

! For glass top larger than 260cm, two bases are provided.

Version with two bases: thanks to the weight of the glass, the top is only placed on the base and does not need to be fixed.

TECHNICAL INFORMATION ON THE MATERIALS

HAND BURNISHED BRASS | The hand burnished brass is the consequence of hand-made process of natural oxidation. The result of this processing is a product that may show marks and colour variations. These differences are inevitable and should not be considered imperfections but evidence of the hand-crafted process. They enhance the beauty and distinctiveness of a unique piece.



Cm

Ø 150 x 65 (lounge)
Ø 160 x 65 (lounge)
Ø 180 x 65 (lounge)

Ø 150 x 74
Ø 160 x 74
Ø 180 x 74

Inches

Ø 59¼" x 25¾"
Ø 63" x 25¾"
Ø 71" x 25¾"

Ø 59¼" x 29¼"
Ø 63" x 29¼"
Ø 71" x 29¼"

Cm

180 x 110 x 65 (lounge)
210 x 110 x 65 (lounge)
230 x 110 x 65 (lounge)

260 x 130 x 65 (lounge)
280 x 130 x 65 (lounge)
300 x 130 x 65 (lounge)

180 x 110 x 74
210 x 110 x 74
230 x 110 x 74

260 x 130 x 74
280 x 130 x 74
300 x 130 x 74

Inches

71" x 43½" x 25¾"
82¾" x 43½" x 25¾"
90¾" x 43½" x 25¾"

102½" x 51¼" x 25¾"
110¼" x 51¼" x 25¾"
118¼" x 51¼" x 25¾"

71" x 43½" x 29¼"
82¾" x 43½" x 29¼"
90¾" x 43½" x 29¼"

102½" x 51¼" x 29¼"
110¼" x 51¼" x 29¼"
118¼" x 51¼" x 29¼"

For technical drawing / p. 74

Pricelist 2023 / p. 16

COMBINAZIONI COMBINATIONS

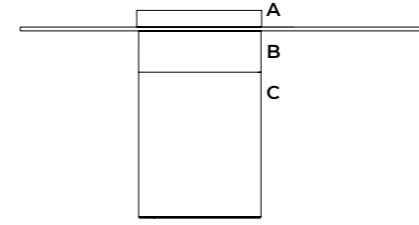

COMB. 1	A  Ottone lucido Bright brass	B  Ottone brunito Burnished brass	C  Frassino tinto nero poro aperto Black open pore stained ash	PIANO/TOP  Cristallo trasparente o "grigio Italia" Transparent or smoked "grigio Italia" glass
COMB. 2	A  Ottone lucido Bright brass	B  Ottone lucido Bright brass	C  Ruggine Rust	PIANO/TOP  Cristallo trasparente o "grigio Italia" Transparent or smoked "grigio Italia" glass
COMB. 3	A  Ottone cromato nero Black chromed brass	B  Ottone cromato nero Black chromed brass	C  Frassino tinto nero poro aperto Black open pore stained ash	PIANO/TOP  Cristallo trasparente o "grigio Italia" Transparent or smoked "grigio Italia" glass
COMB. 4	A  Ottone cromato nero Black chromed brass	B  Ottone ramato Coppered brass	C  Ruggine Rust	PIANO/TOP  Cristallo trasparente o "grigio Italia" Transparent or smoked "grigio Italia" glass
COMB. 5	A  Ottone cromato nero Black chromed brass	B  Ottone brunito Burnished brass	C  Ruggine Rust	PIANO/TOP  Cristallo trasparente o "grigio Italia" Transparent or smoked "grigio Italia" glass
COMB. 6	A  Ottone cromato nero Black chromed brass	B  Ottone brunito Burnished brass	C  Frassino tinto nero poro aperto Black open pore stained ash	PIANO/TOP  Cristallo trasparente o "grigio Italia" Transparent or smoked "grigio Italia" glass
COMB. 7	A  Ottone nichelato lucido Bright nickel-plated brass	B  Metallo nichelato lucido Bright nickel-plated metal	C  Bianco poro aperto White open pore	PIANO/TOP  Cristallo trasparente o "grigio Italia" Transparent or smoked "grigio Italia" glass
COMB. 8	A  Ottone laccato bianco opaco Mat white lacquered brass	B  Metallo laccato bianco lucido Glossy white lacquered metal	C  Bianco poro aperto White open pore	PIANO/TOP  Cristallo trasparente o "grigio Italia" Transparent or smoked "grigio Italia" glass



▲ HAUMEA - T
Combinazione 1: Piano in cristallo trasparente temperato / Base in frassino tinto nero poro aperto / Ottone brunito / Vassoio in ottone lucido
Combination 1: Transparent tempered glass top / Black open pore stained ash base / Burnished brass / Bright brass tray



Maat

Pietro Russo / 2017

Tavolo con struttura in alluminio spazzolato a mano e anodizzato nero. Dettagli in ottone lucido. Piano in marmo lucido naturale Bianco Statuario e Nero Marquinia stratificato e bisellato. Su richiesta realizzabile con piano in legno intarsiato con motivo "Tweed" o piano in cristallo 15mm retroverniciato nei colori del campionario nella versione brillante o satinata e bisello da 35mm. Disponibile versione con piano in cristallo 15mm verniciato nella finitura esclusiva bronzo antico e piombo con bisello da 35mm e struttura in alluminio e dettagli nella stessa finitura del piano.

! Versione con piano in cristallo: grazie al peso del cristallo il piano viene solo appoggiato sulla base e non necessita di fissaggio.

NOTE TECNICHE SUI MATERIALI

MARMO | Il marmo è un materiale naturale di origine sedimentaria che può presentare particolarità come venature, lievi irregolarità superficiali, colorazioni differenti e cristallizzazioni. Queste peculiarità sono da attribuirsi alla naturalezza del materiale e non sono da considerarsi difetti ma caratteristiche tipiche del marmo. Ogni prodotto risulterà unico, esclusivo e non replicabile.

I nostri marmi vengono trattati con un prodotto idrorepellente che permette una maggiore protezione della superficie stessa, aumentando l'impermeabilità. Questo trattamento non esclude la vulnerabilità del marmo alle sostanze acide.

CRISTALLO | Le finiture esclusive risultato della lavorazione manuale realizzata sul cristallo possono presentare striature e differenze cromatiche. Queste caratteristiche non devono essere considerate difetti ma elementi distintivi del processo artigianale che esaltano la bellezza e la peculiarità del pezzo unico.

INTARSIO | L'intarsio è una tecnica di lavorazione artigianale utilizzata per ottenere un particolare disegno e si realizza accostando elementi di materiali differenti (come legno e alluminio) oppure dello stesso materiale. Questa lavorazione rende il prodotto unico ed esclusivo. Le eventuali variazioni cromatiche e di venatura del legno sono da considerarsi caratteristiche del materiale stesso e non possono essere controllate.

Table with black hand brushed anodised aluminium structure. Bright brass details. Natural polished Bianco Statuario and Nero Marquinia marble laminated bevelled top. Also available in inlaid wooden top with "Tweed" pattern. 15mm painted glass top as per samples in the bright or satin version with 35mm bevel, on request. Available version with 15mm glass top painted in the exclusive antique bronze and lead finish with 35mm bevel and aluminium structure and details in the same finish of the glass top.

! Glass version top: thanks to the weight of the glass, the top is only placed on the base and does not need to be fixed.

TECHNICAL INFORMATION ON THE MATERIALS

MARBLE | The marble is a natural material of sedimentary origin that can present particularities such as veins, slight surface irregularities, different colors and crystallizations. These peculiarities are to be attributed to the naturalness of the material and are not to be considered defects but typical characteristics of marble. Each product will be unique, exclusive and non-replicable.

Our marbles are treated with water-repellent products which affords greater protection to the surface of the marble, improving its impermeability. This treatment doesn't exclude the vulnerability of the marble to acid substances.

GLASS | Exclusive finishes, resulting from the craftsmanship on the glass, may show streaks and chromatic differences. These characteristics should not be considered imperfections but distinctive evidence of the hand-made process that enhance the beauty and peculiarity of the unique piece.

INLAY | Inlay is an artisanal technique used to obtain a particular design and is made by combining elements of different materials (such as wood and aluminium) or of the same material. This process makes the product unique and exclusive. Any colour and grain variations of the wood are to be considered as characteristics of the material itself and cannot be controlled.



Cm Marmo

220 x 100 x 75,5
250 x 100 x 75,5
280 x 100 x 75,5

Legno intarsiato

220 x 100 x 76
250 x 100 x 76
280 x 100 x 76

Inches Marble

86¾" x 39½" x 29¾"
98½" x 39½" x 29¾"
110¼" x 39½" x 29¾"

Inlaid wood

86¾" x 39½" x 30"
98½" x 39½" x 30"
110¼" x 39½" x 30"

Cm Cristallo

220 x 100 x 74,5
250 x 100 x 74,5
280 x 100 x 74,5

Inches Glass

86¾" x 39½" x 29½"
98½" x 39½" x 29½"
110¼" x 39½" x 29½"

[For technical drawing / p.75](#)

[Pricelist 2023 / p.18](#)
[Homescapes, intimate portraits / p.74,77](#)

PIANO/TOP



**Marmo Bianco Statuario/
Nero Marquinia
lucido naturale**
Bianco Statuario/
Nero Marquinia marble
natural polished



**Legno intarsiato con
motivo "Tweed"**
Inlaid wood
with "Tweed" pattern



Sample box

**Cristallo brillante/satinato
nei colori del campionario**
Glass bright/satin version
as per samples

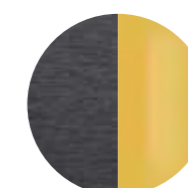

**Alluminio spazzolato nero/
ottone lucido**
Black brushed aluminium/
Bright brass

BASE/BASE

PIANO, BASE E DETTAGLI/ TOP, BASE AND DETAILS

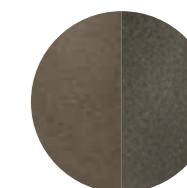

Bronzo antico / Piombo
Antique bronze / Lead



• MAAT
Piano in legno intarsiato con motivo "Tweed"
Inlaid wooden top with "Tweed" pattern



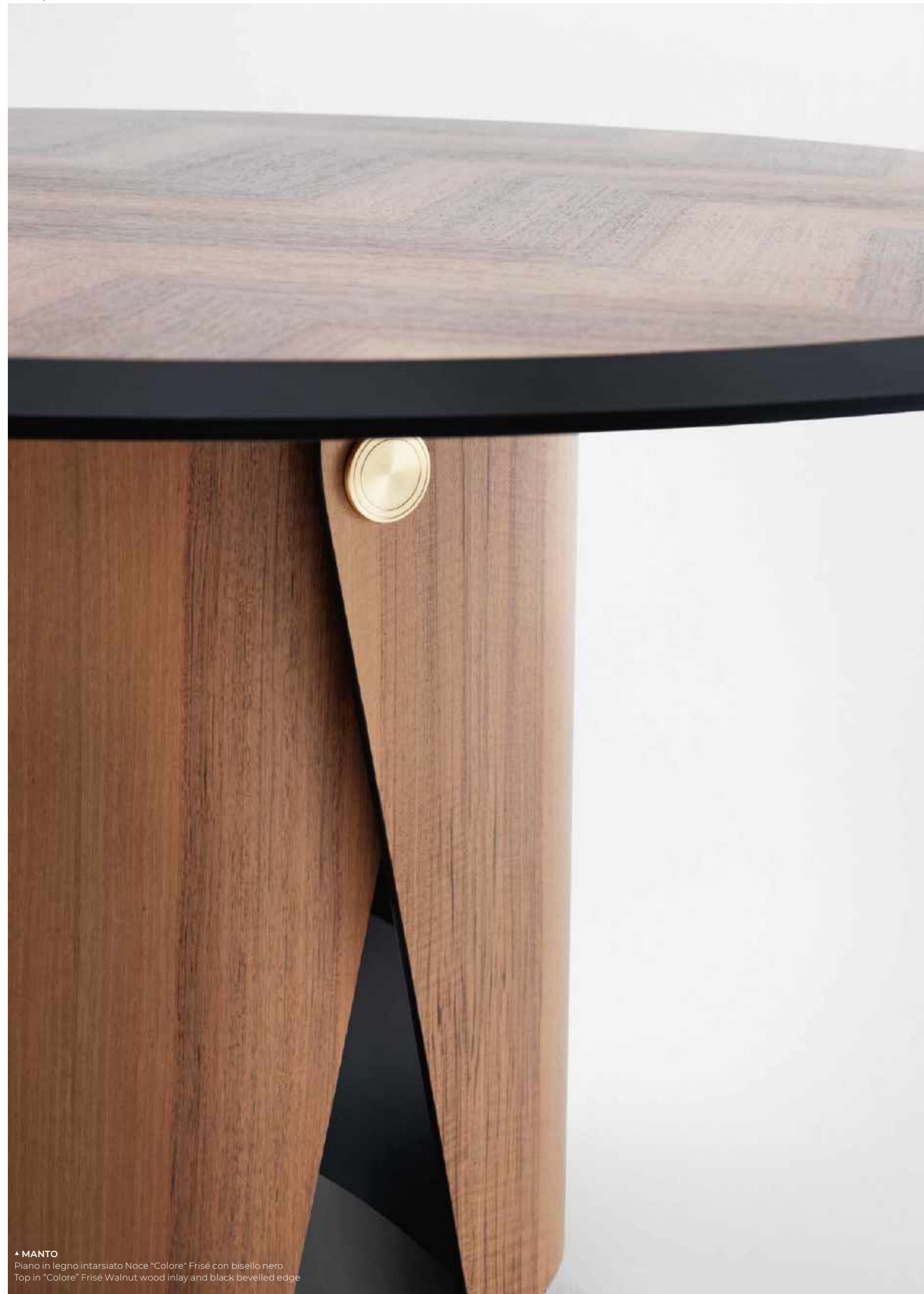

▲ MANTO
Piano in legno intarsiato Noce "Colore" Frisé con bisello nero
Top in "Colore" Frisé Walnut wood inlay and black bevelled edge

Manto

Pietro Russo / 2020

Tavolo con piano in legno Noce "Colore" Frisé intarsiato a spina di pesce con bisello da 60mm in colore nero. Disponibile anche con piano intarsiato in Noce "Colore" Frisé o Acero Frisé grigio scuro con bisello da 60mm nella stessa finitura. Base curvata con bottone in ottone lucido. Disponibile versione "total color" con piano e base curvata in legno con bottone in metallo laccati lucido nei colori "Rosso Persia", "Grigio Londra", "Nero Giza", "Bianco Camargue", "Verde Provenza", "Blu Pacifico", "Bordeaux Etruria" o "Rosa Jaipur". Lazy Susan in appoggio, su richiesta, disponibile nella stessa finitura del piano.

! Il legno è un materiale vivo che subisce un naturale processo di ossidazione che può causare cambiamenti cromatici. Venature e tonalità di colore differenti delle lastre non sono da considerarsi come difetti, ma caratteristiche che esaltano l'unicità del materiale.

NOTE TECNICHE SUI MATERIALI

INTARSIO | L'intarsio è una tecnica di lavorazione artigianale utilizzata per ottenere un particolare disegno e si realizza accostando elementi di materiali differenti (come legno e alluminio) oppure dello stesso materiale. Questa lavorazione rende il prodotto unico ed esclusivo. Le eventuali variazioni cromatiche e di venatura del legno sono da considerarsi caratteristiche del materiale stesso e non possono essere controllate.

Table with top in "Colore" Frisé Walnut herringbone wood inlay and 60mm black bevelled edge. Also available with inlay top in "Colore" Frisé Walnut or dark grey Frisé Maple with 60mm bevelled edge in the same finish. Curved base with bright brass button. Available version "total color" with top and curved base with metal button glossy lacquered in the colours Rosso Persia, "Grigio Londra", "Nero Giza", "Bianco Camargue", "Verde Provenza", "Blu Pacifico", "Bordeaux Etruria" or "Rosa Jaipur". Resting Lazy Susan on request, available in the same finish of the top.

! Wood is a living material and the natural oxidation process can cause chromatic changes. Different grain and colour shades of the wooden slabs are not to be considered as defects, but characteristics that enhance the uniqueness of the material.

TECHNICAL INFORMATION ON THE MATERIALS

INLAY | Inlay is an artisanal technique used to obtain a particular design and is made by combining elements of different materials (such as wood and aluminium) or of the same material. This process makes the product unique and exclusive. Any colour and grain variations of the wood are to be considered as characteristics of the material itself and cannot be controlled.



Cm

Ø 150 x 73
Ø 180 x 73

Lazy Susan

Ø 70 (Ø 150 x 73)
Ø 100 (Ø 180 x 73)

Inches

Ø 59¼" x 28¾"
Ø 71" x 28¾"

Lazy Susan

Ø 27¾" (Ø 59¼" x 28¾")
Ø 39½" (Ø 71" x 28¾")

[For technical drawing / p.75](#)

[Pricelist 2023 / p.19](#)
[Homescapes, embracing beauty / p.75](#)

PIANO/TOP

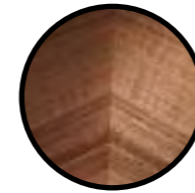

Legno Noce "Colore" Frisé con bisello nero
"Colore" Frisé Walnut wood with black bevelled edge

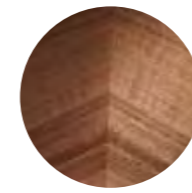

Legno Noce "Colore" Frisé "Colore" Frisé Walnut wood



Legno Acero Frisé grigio scuro
Maple Frisé dark grey wood

BOTTONE/BUTTON

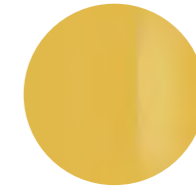

Ottone lucido
Bright brass

VERSIONE "TOTAL COLOR" / "TOTAL COLOR" VERSION

PIANO/BASE LEGNO E BOTTONE METALLO WOODEN TOP/BASE AND METAL BUTTON

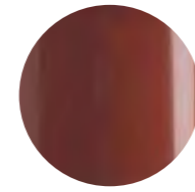

Laccato lucido
"Rosso Persia"
Glossy lacquered
"Rosso Persia"

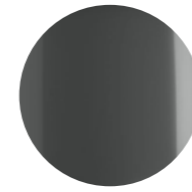

Laccato lucido
"grigio Londra"
Glossy lacquered
"Grigio Londra"



Laccato lucido
"Nero Giza"
Glossy lacquered
"Nero Giza"

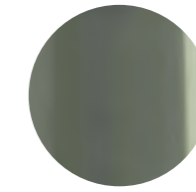

Laccato lucido
"Verde Provenza"
Glossy lacquered
"Verde Provenza"

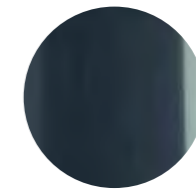

Laccato lucido
"Blu Pacifico"
Glossy lacquered "Blu Pacifico"



Laccato lucido
"Bianco Camargue"
Glossy lacquered
"Bianco Camargue"

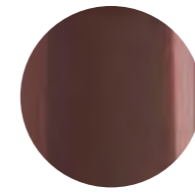

Laccato lucido
"Bordeaux Etruria"
Glossy lacquered
"Bordeaux Etruria"

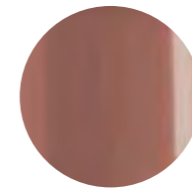

Laccato lucido "Rosa Jaipur"
Glossy lacquered "Rosa Jaipur"



▲ MANTO
Piano in legno intarsiato Acero Frisé grigio scuro con lazy susan
Top in Maple Frisé dark grey wood inlay with lazy susan



▲ MANTO
Piano in legno intarsiato Noce "Colore" Frisé con lazy susan
Top in "Colore" Frisé Walnut wood inlay with lazy susan



▲ MANTO
Versione "total color" Bordeaux Etruria laccato lucido
Bordeaux Etruria glossy lacquered "total color" version





Manto Oval

Pietro Russo / 2021

Tavolo con piano in legno Noce "Colore" Frisé intarsiato con bisello da 40mm in colore nero. Base curvata con bottone in ottone lucido.

! Il legno è un materiale vivo che subisce un naturale processo di ossidazione che può causare cambiamenti cromatici. Venature e tonalità di colore differenti delle lastre non sono da considerarsi come difetti, ma caratteristiche che esaltano l'unicità del materiale.

NOTE TECNICHE SUI MATERIALI

INTARSIO | L'intarsio è una tecnica di lavorazione artigianale utilizzata per ottenere un particolare disegno e si realizza accostando elementi di materiali differenti (come legno e alluminio) oppure dello stesso materiale. Questa lavorazione rende il prodotto unico ed esclusivo. Le eventuali variazioni cromatiche e di venatura del legno sono da considerarsi caratteristiche del materiale stesso e non possono essere controllate.

Table with top in "Colore" Frisé walnut wood inlay with 40mm black bevelled edge. Curved base with bright brass button.

! Wood is a living material and the natural oxidation process can cause chromatic changes. Different grain and colour shades of the wooden slabs are not to be considered as defects, but characteristics that enhance the uniqueness of the material.

TECHNICAL INFORMATION ON THE MATERIALS

INLAY | Inlay is an artisanal technique used to obtain a particular design and is made by combining elements of different materials (such as wood and aluminium) or of the same material. This process makes the product unique and exclusive. Any colour and grain variations of the wood are to be considered as characteristics of the material itself and cannot be controlled.



Cm

240 x 110 x 73
280 x 110 x 73
300 x 110 x 73

Inches

94½" x 43½" x 28¾"
110¼" x 43½" x 28¾"
118¼" x 43½" x 28¾"

[For technical drawing / p. 75](#)

[Pricelist 2023 / p. 20](#)
[Homescapes, intimate portraits / pp. 40, 46](#)

PIANO/TOP



Legno Noce "Colore" Frisé
con bisello nero
"Colore" Frisé Walnut wood
with black beveled edge

DETTAGLI/DETAILS

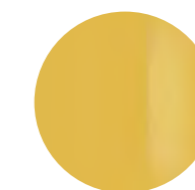

Ottone lucido
Bright brass



▲ OTO
Piano in cristallo retroverniciato liquirizia satinato
Satin liquorice painted glass top

Oto

Oscar e Gabriele Buratti / 2015

Tavolo con piano in cristallo 15 mm retroverniciato nei colori nero, blu grigio e liquirizia nella versione brillante o satinata. Piano con bisello 25mm. Struttura in metallo verniciato lucido. Disponibile anche nella versione con piano in cristallo e struttura in metallo verniciati bronzo patinato.

NOTE TECNICHE SUI MATERIALI

CRISTALLO | Le finiture esclusive risultato della lavorazione manuale realizzata sul cristallo possono presentare striature e differenze cromatiche. Queste caratteristiche non devono essere considerate difetti ma elementi distintivi del processo artigianale che esaltano la bellezza e la peculiarità del pezzo unico.

Table with 15 mm bevelled and painted glass top in the colours black, blue grey and liquorice in the bright or satin version. Top with 25mm bevel. Bright lacquered metal structure. Also available with patinated bronze painted glass top and metal structure.

TECHNICAL INFORMATION ON THE MATERIALS

GLASS | Exclusive finishes, resulting from the craftsmanship on the glass, may show streaks and chromatic differences. These characteristics should not be considered imperfections but distinctive evidence of the hand-made process that enhance the beauty and peculiarity of the unique piece.



Cm

Ø 90 x 74
Ø 100 x 74
Ø 120 x 74
Ø 130 x 74
Ø 140 x 74
Ø 150 x 74

Inches

Ø 35½" x 29¼"
Ø 39½" x 29¼"
Ø 47¼" x 29¼"
Ø 51¼" x 29¼"
Ø 55¼" x 29¼"
Ø 59¼" x 29¼"

For technical drawing / p. 76

Pricelist 2023 / p. 21

PIANO E STRUTTURA/TOP AND STRUCTURE

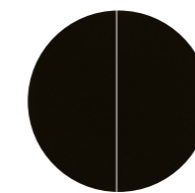

Cristallo retroverniciato nero brillante/satinato
Bright/satin black painted glass

Metallo verniciato nero lucido
Bright black lacquered metal

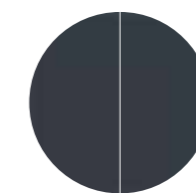

Cristallo retroverniciato blu grigio brillante/satinato
Bright/satin blue grey painted glass

Metallo verniciato blu grigio lucido
Bright blue grey lacquered metal

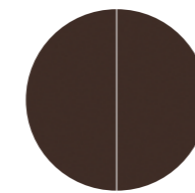

Cristallo retroverniciato liquirizia brillante/satinato
Bright/satin liquorice painted glass

Metallo verniciato liquirizia lucido
Bright liquorice lacquered metal

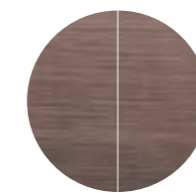

Cristallo verniciato bronzo patinato
Patinated bronze painted glass

Metallo verniciato bronzo patinato
Patinated bronze lacquered metal



▲ **OTO BIG**
Piano e base in marmo lucido naturale Bianco Carrara Gioia
Top and base in natural polished Bianco Carrara Gioia marble

Oto Big

Oscar e Gabriele Buratti / 2018

Tavolo con piano e base in marmo Bianco Carrara Gioia lucido naturale oppure nella versione in marmo Nero Marquinia levigato opaco. Piatto a terra in metallo ottonato lucido. Su richiesta piano girevole in appoggio in marmo nella stessa finitura del piano.

! Diametro massimo realizzabile 180cm / 71"

NOTE TECNICHE SUI MATERIALI

MARMO | Il marmo è un materiale naturale di origine sedimentaria che può presentare particolarità come venature, lievi irregolarità superficiali, colorazioni differenti e cristallizzazioni. Queste peculiarità sono da attribuirsi alla naturalezza del materiale e non sono da considerarsi difetti ma caratteristiche tipiche del marmo. Ogni prodotto risulterà unico, esclusivo e non replicabile. I nostri marmi vengono trattati con un prodotto idrorepellente che permette una maggiore protezione della superficie stessa, aumentando l'impermeabilità. Questo trattamento non esclude la vulnerabilità del marmo alle sostanze acide.

Table with top and base in natural polished Bianco Carrara Gioia marble or honed mat Nero Marquinia marble. Glossy brass-plated metal bottom plate. Marble rotating plate in the same finish of the top resting on the top, on request.

! Maximum achievable diameter 180cm / 71"

TECHNICAL INFORMATION ON THE MATERIALS

MARBLE | The marble is a natural material of sedimentary origin that can present particularities such as veins, slight surface irregularities, different colors and crystallizations. These peculiarities are to be attributed to the naturalness of the material and are not to be considered defects but typical characteristics of marble. Each product will be unique, exclusive and non-replicable. Our marbles are treated with water-repellent products which affords greater protection to the surface of the marble, improving its impermeability. This treatment doesn't exclude the vulnerability of the marble to acid substances.



Cm
Ø 160 x 73
Ø 180 x 73

Lazy Susan
Ø 80 (Ø160 x 73)
Ø 100 (Ø180 x 73)

Inches
Ø 63" x 28¾"
Ø 71" x 28¾"

Lazy Susan
Ø 31½" (Ø63" x 28¾")
Ø 39½" (Ø71" x 28¾")

[For technical drawing / p. 76](#)

[Pricelist 2023 / p. 22](#)
[Homescapes, intimate portraits / p. 29](#)

PIANO E BASE/TOP AND BASE



Marmo lucido naturale
Bianco Carrara Gioia
Natural polished
Bianco Carrara Gioia marble



Marmo levigato opaco
Nero Marquinia
Honed mat
Nero Marquinia marble

PIATTO A TERRA/BOTTOM PLATE



Metallo ottonato lucido
Glossy brass-plated metal

Oto Medium

Oscar e Gabriele Buratti / 2022

Tavolo con piano in marmo 20mm Bianco Carrara Gioia lucido naturale e struttura in metallo verniciato bronzo antico. Disponibile versione con piano in marmo 20mm Nero Marquinia levigato opaco e struttura in metallo verniciato piombo.

! Diametro massimo realizzabile 150cm / 59¼"

NOTE TECNICHE SUI MATERIALI

MARMO | Il marmo è un materiale naturale di origine sedimentaria che può presentare particolarità come venature, lievi irregolarità superficiali, colorazioni differenti e cristallizzazioni. Queste peculiarità sono da attribuirsi alla naturalezza del materiale e non sono da considerarsi difetti ma caratteristiche tipiche del marmo. Ogni prodotto risulterà unico, esclusivo e non replicabile. I nostri marmi vengono trattati con un prodotto idrorepellente che permette una maggiore protezione della superficie stessa, aumentando l'impermeabilità. Questo trattamento non esclude la vulnerabilità del marmo alle sostanze acide.

Table with 20mm natural polished Bianco Carrara Gioia marble and antique bronze lacquered metal structure. Available version with 20mm honed mat Nero Marquinia marble and lead lacquered metal structure.

! Maximum achievable diameter 150cm / 59¼"

TECHNICAL INFORMATION ON THE MATERIALS

MARBLE | The marble is a natural material of sedimentary origin that can present particularities such as veins, slight surface irregularities, different colors and crystallizations. These peculiarities are to be attributed to the naturalness of the material and are not to be considered defects but typical characteristics of marble. Each product will be unique, exclusive and non-replicable. Our marbles are treated with water-repellent products which affords greater protection to the surface of the marble, improving its impermeability. This treatment doesn't exclude the vulnerability of the marble to acid substances.



Cm

Ø 130 x 73
Ø 140 x 73
Ø 150 x 73

Inches

Ø 51¼" x 28¾"
Ø 55¼" x 28¾"
Ø 59¼" x 28¾"

[For technical drawing / p. 76](#)

[Pricelist 2023 / p. 23](#)

PIANO/TOP



Marmo lucido naturale Bianco Carrara Gioia
Natural polished Bianco Carrara Gioia marble

STRUTTURA/STRUCTURE



Metallo verniciato bronzo antico
Antique bronze lacquered metal

PIANO/TOP



Marmo levigato opaco Nero Marquinia
Honed mat Nero Marquinia marble

STRUTTURA/STRUCTURE



Metallo verniciato piombo
Lead lacquered metal

▲ OTO MEDIUM

Piano in marmo lucido naturale Bianco Carrara Gioia / Struttura in metallo verniciato bronzo antico
Top in natural polished Bianco Carrara Gioia marble / Antique bronze lacquered metal structure.



▲ **PLATIUM**
Piano in cristallo retroverniciato nero brillante / Base in marmo lucido naturale Sahara Noir
Bright black painted glass top / Natural polished Sahara Noir marble base

Platium

Oscar e Gabriele Buratti / 2016

Tavolo con piano in cristallo 15mm retroverniciato nero nella versione brillante e satinata. Importante bisellatura di 40mm su due lati del piano. Base in legno rivestito in marmo lucido naturale 20mm Sahara Noir e piatto a terra in acciaio inox lucido "supermirror". Disponibile anche nella versione con piano in cristallo 15mm e base in legno rivestito in cristallo 6mm retroverniciato nei colori nero, blue grigio o liquirizia, nella versione brillante o satinata oppure verniciata nella finitura esclusiva spazzolata "Cashmere" gold grey o tanthracite.

! Grazie al peso del cristallo il piano viene solo appoggiato sulla base e non necessita di fissaggio.

NOTE TECNICHE SUI MATERIALI

CRISTALLO | Le finiture esclusive risultato della lavorazione manuale realizzata sul cristallo possono presentare striature e differenze cromatiche. Queste caratteristiche non devono essere considerate difetti ma elementi distintivi del processo artigianale che esaltano la bellezza e la peculiarità del pezzo unico.

MARMO | Il marmo è un materiale naturale di origine sedimentaria che può presentare particolarità come venature, lievi irregolarità superficiali, colorazioni differenti e cristallizzazioni. Queste peculiarità sono da attribuirsi alla naturalezza del materiale e non sono da considerarsi difetti ma caratteristiche tipiche del marmo. Ogni prodotto risulterà unico, esclusivo e non replicabile.

Table with 15mm black painted glass top in the bright or satin version. 40mm bevelled edges on two sides of the top. Wooden base covered with 20mm natural polished Sahara Noir marble and "supermirror" bright stainless steel bottom plate. Also available with 15mm glass top and wooden base covered with 6mm painted glass in the colours black, blue grey or liquorice, in the bright or satin version or painted with the exclusive "Cashmere" brushed finish in the colours gold grey or anthracite.

! Thanks to the weight of the glass, the top is only placed on the base and does not need to be fixed.

TECHNICAL INFORMATION ON THE MATERIALS

GLASS | Exclusive finishes, resulting from the craftsmanship on the glass, may show streaks and chromatic differences. These characteristics should not be considered imperfections but distinctive evidence of the hand-made process that enhance the beauty and peculiarity of the unique piece.

MARBLE | The marble is a natural material of sedimentary origin that can present particularities such as veins, slight surface irregularities, different colors and crystallizations. These peculiarities are to be attributed to the naturalness of the material and are not to be considered defects but typical characteristics of marble. Each product will be unique, exclusive and non-replicable.



Cm

260 x 120 x 74
280 x 120 x 74
300 x 120 x 74

Inches

102½" x 47¼" x 29¼"
110¼" x 47¼" x 29¼"
118¼" x 47¼" x 29¼"

[For technical drawing / p.77](#)

[Pricelist 2023 / p.24](#)
[Homescapes, embracing beauty / p.15](#)

PIANO/TOP

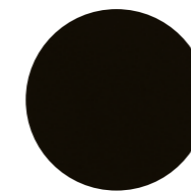

Cristallo retroverniciato
nero brillante/satinato
Bright/satin black painted
glass

BASE/BASE

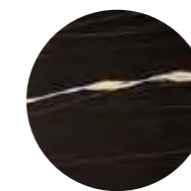

Marmo lucido naturale
Sahara Noir
Natural polished
Sahara Noir marble

PIANO E BASE / TOP AND BASE

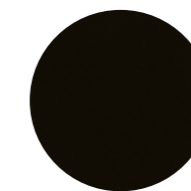

Cristallo retroverniciato
nero brillante/satinato
Bright/satin black
painted glass

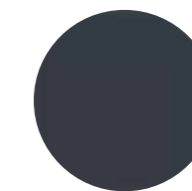

Cristallo retroverniciato
blu grigio brillante/satinato
Bright/satin blue-grey
painted glass

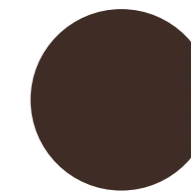

Cristallo retroverniciato
liquirizia brillante/satinato
Bright/satin liquorice black
painted glass

PIANO A TERRA / BOTTOM PLATE

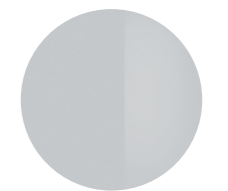

Acciaio inox lucido
"supermirror"
"Supermirror" bright
stainless steel



Cristallo verniciato
"Cashmere" gold grey
"Cashmere" gold grey
painted glass



Cristallo verniciato
"Cashmere" anthracite
"Cashmere" anthracite
painted glass

Platium Round

Oscar e Gabriele Buratti / 2018

Tavolo con piano in frassino spazzolato tinto nero. Piano girevole semi-incassato in cristallo temperato retroverniciato nero brillante 10mm con bisello da 35mm. Base in legno rivestito in marmo lucido naturale 20mm Sahara Noir. Piatto a terra in acciaio inox lucido "supermirror".

Table with black stained brushed ash top. Semi-recessed rotating plate in 10mm tempered black bright painted glass with 35mm bevel. Wooden base covered with 20mm natural polished Sahara Noir marble base and "supermirror" bright stainless steel bottom plate.

! Il piano girevole è sporgente rispetto al piano di circa 5 millimetri.

! The rotating plate is protruding from the top by about 5 millimeters.

NOTE TECNICHE SUI MATERIALI

MARMO | Il marmo è un materiale naturale di origine sedimentaria che può presentare particolarità come venature, lievi irregolarità superficiali, colorazioni differenti e cristallizzazioni. Queste peculiarità sono da attribuirsi alla naturalezza del materiale e non sono da considerarsi difetti ma caratteristiche tipiche del marmo. Ogni prodotto risulterà unico, esclusivo e non replicabile.

TECHNICAL INFORMATION ON THE MATERIALS

MARBLE | The marble is a natural material of sedimentary origin that can present particularities such as veins, slight surface irregularities, different colors and crystallizations. These peculiarities are to be attributed to the naturalness of the material and are not to be considered defects but typical characteristics of marble. Each product will be unique, exclusive and non-replicable.



Cm

Ø 180 x 76
Ø 200 x 76
Ø 220 x 76
Ø 240 x 76

Inches

Ø 71" x 30"
Ø 78¾" x 30"
Ø 86¾" x 30"
Ø 94½" x 30"

[For technical drawing / p.77](#)

[Pricelist 2023 / p.25](#)

PIANO/TOP

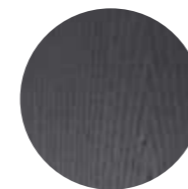

Frassino spazzolato tinto nero
Black stained brushed ash

BASE/BASE

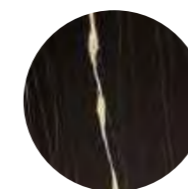

Marmo lucido naturale Sahara Noir
Natural polished Sahara Noir marble

PIATTO A TERRA / BOTTOM PLATE



Acciaio inox lucido "supermirror"
"Supermirror" bright stainless steel

PIANO GIREVOLE / ROTATING PLATE

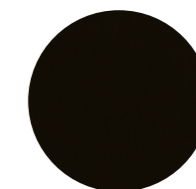

Cristallo retroverniciato nero brillante
Bright black painted glass

▲ **PLATIUM ROUND**
Piano in frassino spazzolato tinto nero / Piano girevole in cristallo retroverniciato nero brillante
Black stained brushed ash top / Black bright painted glass rotating plate

Platium System

Oscar e Gabriele Buratti / 2018

Tavolo con piano modulare in cristallo 15mm e base in legno rivestito in cristallo 6mm decorato a mano nella finitura esclusiva bronzo antico e piombo. Disponibile anche versione in cristallo verniciato bronzo patinato. Importante bisellatura di 40mm su due lati del piano. Dettaglio di giunzione tra i piani in ottone satinato. Piatto a terra in acciaio inox lucido "supermirror". Disponibile versione con base in legno rivestito in marmo lucido naturale 20 mm Sahara Noir, Stardust Grey o Calacatta Vagli Oro e piano in cristallo verniciato bronzo antico, piombo o bronzo patinato nelle combinazioni predefinite.

NOTE TECNICHE SUI MATERIALI

MARMO | Il marmo è un materiale naturale di origine sedimentaria che può presentare particolarità come venature, lievi irregolarità superficiali, colorazioni differenti e cristallizzazioni. Queste peculiarità sono da attribuirsi alla naturalezza del materiale e non sono da considerarsi difetti ma caratteristiche tipiche del marmo. Ogni prodotto risulterà unico, esclusivo e non replicabile.

CRISTALLO | Le finiture esclusive risultato della lavorazione manuale realizzata sul cristallo possono presentare striature e differenze cromatiche. Queste caratteristiche non devono essere considerate difetti ma elementi distintivi del processo artigianale che esaltano la bellezza e la peculiarità del pezzo unico.

Table with 15mm modular glass top and wooden base covered by 6mm glass, decorated by hand with an exclusive finish antique bronze and lead. Also available version with patinated bronze painted glass. Large bevel of 40mm on the two sides. Junction detail between tops in satin brass.

"Supermirror" bright stainless steel bottom plate. Available version with wooden base covered by 20mm natural polished Sahara Noir, Stardust Grey or Calacatta Vagli Oro marble and antique bronze, lead or patinated bronze painted glass top in predefined combinations.

TECHNICAL INFORMATION ON THE MATERIALS

MARBLE | The marble is a natural material of sedimentary origin that can present particularities such as veins, slight surface irregularities, different colors and crystallizations. These peculiarities are to be attributed to the naturalness of the material and are not to be considered defects but typical characteristics of marble. Each product will be unique, exclusive and non-replicable.

GLASS | Exclusive finishes, resulting from the craftsmanship on the glass, may show streaks and chromatic differences. These characteristics should not be considered imperfections but distinctive evidence of the hand-made process that enhance the beauty and peculiarity of the unique piece.



Cm

260 x 120 x 74
280 x 120 x 74
300 x 120 x 74
360 x 120 x 74
400 x 120 x 74
460 x 120 x 74
500 x 120 x 74

Inches

102½" x 47¼" x 29¼"
110¼" x 47¼" x 29¼"
118¼" x 47¼" x 29¼"
141¼" x 47¼" x 29¼"
157½" x 47¼" x 29¼"
181¼" x 47¼" x 29¼"
197" x 47¼" x 29¼"

[For technical drawing / p. 77](#)

[Pricelist 2023 / p. 26](#)
[Homescapes, sense of materials / p. 44](#)
[Homescapes, gentle attitude / pp. 81, 83](#)

PIANO/TOP

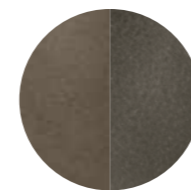

**Cristallo verniciato
Bronzo antico / Piombo**
Antique bronze / Lead
painted glass



**Cristallo verniciato
bronzo patinato**
Patinated bronze
painted glass

BASE/BASE

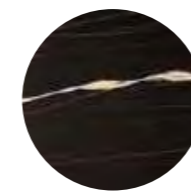

**Marmo lucido naturale
Sahara Noir**
Natural polished
Sahara Noir marble



**Marmo lucido naturale
Stardust Grey**
Natural polished
Stardust Grey marble



**Marmo lucido naturale
Calacatta Vagli Oro**
Natural polished
Calacatta Vagli Oro marble

PIATTO A TERRA / BOTTOM PLATE



**Acciaio inox lucido
"supermirror"**
"Supermirror" bright
stainless steel

DETTAGLI/DETAILS



Ottone satinato
Satin brass

▲ PLATIUM SYSTEM
Piano decorato nella finitura esclusiva bronzo antico / Dettaglio in ottone satinato
Decorated by hand with an exclusive finish antique bronze top / Satin brass top detail

Platium W

Oscar e Gabriele Buratti / 2017

Tavolo con piano in frassino spazzolato tinto nero con bisello da 50mm. Base in legno rivestito in marmo lucido naturale 20mm Sahara Noir o Stardust Grey e piatto a terra in acciaio inox lucido "supermirror".

Table with black stained brushed ash top with 50mm bevel. Wooden base covered with 20mm natural polished Sahara Noir or Grey Stardust marble and "supermirror" bright stainless steel bottom plate.

NOTE TECNICHE SUI MATERIALI

MARMO | Il marmo è un materiale naturale di origine sedimentaria che può presentare particolarità come venature, lievi irregolarità superficiali, colorazioni differenti e cristallizzazioni. Queste peculiarità sono da attribuirsi alla naturalezza del materiale e non sono da considerarsi difetti ma caratteristiche tipiche del marmo. Ogni prodotto risulterà unico, esclusivo e non replicabile.

TECHNICAL INFORMATION ON THE MATERIALS

MARBLE | The marble is a natural material of sedimentary origin that can present particularities such as veins, slight surface irregularities, different colors and crystallizations. These peculiarities are to be attributed to the naturalness of the material and are not to be considered defects but typical characteristics of marble. Each product will be unique, exclusive and non-replicable.



Cm

260 x 120 x 75
280 x 120 x 75
300 x 120 x 75

Inches

102½" x 47¼" x 29¾"
110¾" x 47¼" x 29¾"
118¼" x 47¼" x 29¾"

[For technical drawing / p. 78](#)

[Pricelist 2023 / p. 28](#)

PIANO/TOP

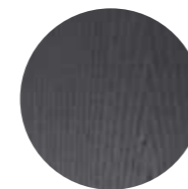

Frassino spazzolato tinto nero
Black stained brushed ash

BASE/BASE

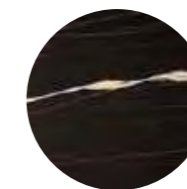

Marmo lucido naturale Sahara Noir
Natural polished Sahara Noir marble



Marmo lucido naturale Stardust Grey
Natural polished Stardust Grey marble

PIATTO A TERRA / BOTTOM PLATE

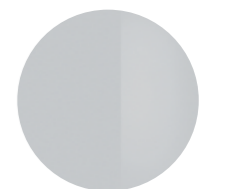

Acciaio inox lucido "supermirror"
"Supermirror" bright stainless steel

▲ **PLATIUM W**
Piano in frassino tinto nero / Base in marmo Stardust grigio
Black stained brushed ash top / Grey Stardust marble base

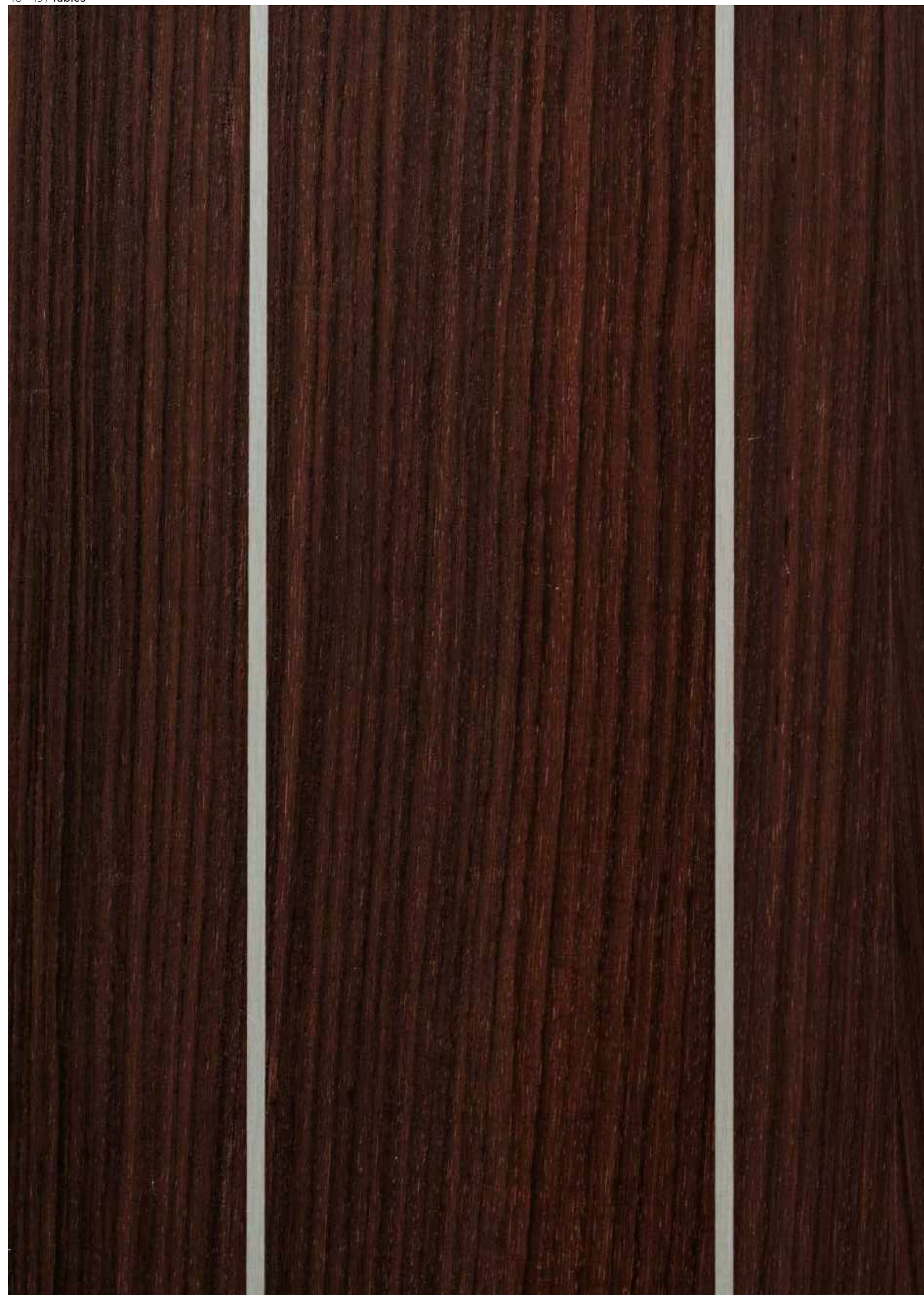

Prism

david/nicolas / 2019

Tavolo in legno con moderno ed elegante intarsio di palissandro India e alluminio naturale. Caratteristica del piano, è l'importante curvatura inferiore.

Wooden table with modern and elegant marquetry of India rosewood and aluminium. The top features a distinctive bottom curve.

NOTE TECNICHE SUI MATERIALI

INTARSIO | L'intarsio è una tecnica di lavorazione artigianale utilizzata per ottenere un particolare disegno e si realizza accostando elementi di materiali differenti (come legno e alluminio) oppure dello stesso materiale. Questa lavorazione rende il prodotto unico ed esclusivo. Le eventuali variazioni cromatiche e di venatura del legno sono da considerarsi caratteristiche del materiale stesso e non possono essere controllate.

TECHNICAL INFORMATION ON THE MATERIALS

INLAY | Inlay is an artisanal technique used to obtain a particular design and is made by combining elements of different materials (such as wood and aluminium) or of the same material. This process makes the product unique and exclusive. Any colour and grain variations of the wood are to be considered as characteristics of the material itself and cannot be controlled.



Cm
260 x 125 x 74
280 x 125 x 74

Inches
102½" x 49¼" x 29¼"
110¼" x 49¼" x 29¼"

[For technical drawing / p. 78](#)

[Pricelist 2023 / p. 29](#)
[Homescapes, sense of materials / p. 60](#)

STRUTTURA/STRUCTURE

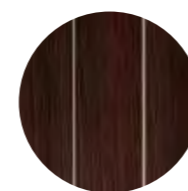

**Legno palissandro India
e alluminio naturale**
India rosewood
and aluminium



▲ SHIRO
Piano intarsiato in legno "Ebano Capri"
Inlaid wooden top in the finish "Ebano Capri"

Shiro

Oscar e Gabriele Buratti / 2021

Tavolo con piano intarsiato in legno nella finitura "Ebano Capri". Disponibile anche con piano in marmo lucido naturale Calacatta Vagli Oro, Bianco Carrara Gioia o Verde Alpi. Basi ovalizzate rivestite in massello fresato di legno nella finitura "Ebano Capri" e dettagli in metallo cromato nero.

Table with inlaid wooden top in the finish "Ebano Capri". Also available with natural polished Calacatta Vagli Oro, Bianco Carrara Gioia or Verde Alpi marble. Ovalized bases covered by solid milled wood in the finish "Ebano Capri" and black chromed metal details.

NOTE TECNICHE SUI MATERIALI

MARMO | Il marmo è un materiale naturale di origine sedimentaria che può presentare particolarità come venature, lievi irregolarità superficiali, colorazioni differenti e cristallizzazioni. Queste peculiarità sono da attribuirsi alla naturalezza del materiale e non sono da considerarsi difetti ma caratteristiche tipiche del marmo. Ogni prodotto risulterà unico, esclusivo e non replicabile. I nostri marmi vengono trattati con un prodotto idrorepellente che permette una maggiore protezione della superficie stessa, aumentando l'impermeabilità. Questo trattamento non esclude la vulnerabilità del marmo alle sostanze acide.

INTARSIO | L'intarsio è una tecnica di lavorazione artigianale utilizzata per ottenere un particolare disegno e si realizza accostando elementi di materiali differenti (come legno e alluminio) oppure dello stesso materiale. Questa lavorazione rende il prodotto unico ed esclusivo. Le eventuali variazioni cromatiche e di venatura del legno sono da considerarsi caratteristiche del materiale stesso e non possono essere controllate.

TECHNICAL INFORMATION ON THE MATERIALS

MARBLE | The marble is a natural material of sedimentary origin that can present particularities such as veins, slight surface irregularities, different colors and crystallizations. These peculiarities are to be attributed to the naturalness of the material and are not to be considered defects but typical characteristics of marble. Each product will be unique, exclusive and non-replicable. Our marbles are treated with water-repellent products which affords greater protection to the surface of the marble, improving its impermeability. This treatment doesn't exclude the vulnerability of the marble to acid substances.

INLAY | Inlay is an artisanal technique used to obtain a particular design and is made by combining elements of different materials (such as wood and aluminium) or of the same material. This process makes the product unique and exclusive. Any colour and grain variations of the wood are to be considered as characteristics of the material itself and cannot be controlled.



Cm

240 x 120 x 74
280 x 120 x 74

240 x 100 x 74
280 x 110 x 74

Inches

94½" x 47½" x 29¼"
110¾" x 47¼" x 29¼"

94½" x 39½" x 29¼"
110¾" x 43½" x 29¼"

[For technical drawing / p. 79](#)

[Pricelist 2023 / p. 30](#)
[Homescapes, intimate portraits / p. 82](#)

PIANO/TOP

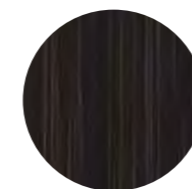

"Ebano Capri"
"Ebano Capri"



Marmo lucido naturale
Bianco Carrara Gioia
Natural polished
Bianco Carrara Gioia marble



Marmo lucido naturale
Calacatta Vagli Oro
Natural polished
Calacatta Vagli Oro marble

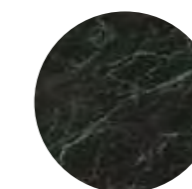

Marmo lucido naturale
Verde Alpi
Natural polished
Verde Alpi marble

BASE/BASE

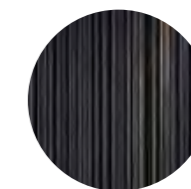

"Ebano Capri"
"Ebano Capri"

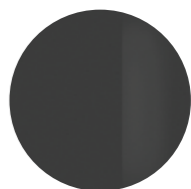

Metallo cromato nero
Black chromed metal

DETTAGLI/DETAILS



▲ **SIMPÒDIO**
Base in cemento alleggerito avorio
Lightened concrete in the colour ivory base

Simpòdio

Pinuccio Borgonovo / 2022

Tavolo con piano in cristallo 12mm temperato, disponibile in extralight o "grigio Italia". Basi in cemento alleggerito color avorio o carbone. Parti metalliche in metallo laccato color "fango".

Table with 12mm tempered glass top, available in extralight or smoked "grigio Italia". Bases in lightened concrete in the colour ivory or charcoal. Metal parts lacquered in the "fango" colour.



	Cm	Inches
○	Ø 120 x 74,5	Ø 47¼" x 29½"
	Ø 140 x 74,5	Ø 55¼" x 29½"
	Ø 160 x 74,5	Ø 63" x 29½"
	Ø 180 x 74,5	Ø 71" x 29½"
	Ø 200 x 74,5	Ø 78¾" x 29½"
□	260 x 120 x 74,5	102½" x 47¼" x 29½"
	260 x 140 x 74,5	102½" x 55¼" x 29½"
	280 x 140 x 74,5	110¼" x 55¼" x 29½"
	300 x 140 x 74,5	118¾" x 55¼" x 29½"
	320 x 140 x 74,5	126" x 55¼" x 29½"
◻	260 x 120 x 74,5	102½" x 47¼" x 29½"

For technical drawing / p. 29

Pricelist 2023 / p.31
Homescapes, gentle attitude / pp. 69, 70

PIANO/TOP



Cristallo extralight
Extralight glass

BASE/BASE



Cristallo "grigio Italia"
Smoked "grigio Italia" glass

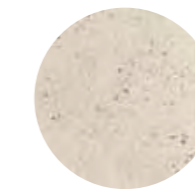

Cemento alleggerito avorio
Lightened concrete in
ivory colour

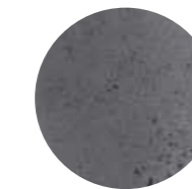

Cemento alleggerito carbone
Lightened concrete in
charcoal colour

PARTI METALLICHE/ METAL PARTS



Legno laccato color "fango"
Wooden lacquered "fango"
colour



▲ **SIMPÒDIO SYSTEM**
Piano in cristallo extrlight/ Basi in cemento alleggerito avorio
Extralight glass top/Lightened concrete in the colour ivory bases

Simpòdio System

Pinuccio Borgonovo / 2022

Tavolo con piano in cristallo 12mm temperato, disponibile in extralight, "grigio Italia" o verniciato nella finitura esclusiva bronzo antico o piombo.
Basi in cemento alleggerito color avorio o carbone.
Parti metalliche in metallo laccato color fango.

Table with 12mm tempered glass top, available in extralight, smoked "grigio Italia" or painted with the exclusive antique bronze and lead finish.
Bases in lightened concrete in the colour ivory or charcoal.
Metal parts lacquered in the "fango" colour.



Cm

260 x 140 x 74,5
280 x 140 x 74,5
300 x 140 x 74,5
320 x 140 x 74,5
350 x 150 x 74,5
390 x 150 x 74,5
430 x 150 x 74,5

Inches

102½" x 55¼" x 29½"
110¼" x 55¼" x 29½"
118¼" x 55¼" x 29½"
126" x 55¼" x 29½"
138" x 59¼" x 29½"
153¾" x 59¼" x 29½"
169½" x 59¼" x 29½"

For technical drawing / p. 80

Pricelist 2023 / p. 32
Homescapes, gentle attitude / pp. 28, 35

PIANO/TOP



Cristallo extralight
Extralight glass



Cristallo "grigio Italia"
Smoked "grigio Italia" glass

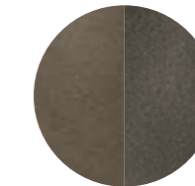

Bronzo antico / Piombo
Antique bronze / Lead

BASE/BASE



Cemento alleggerito avorio
Lightened concrete in
ivory colour

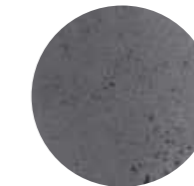

Cemento alleggerito
carbone
Lightened concrete
in charcoal colour

PARTI METALLICHE/ METAL PARTS



Legno laccato color "fango"
Wooden lacquered "fango"
colour



▲ YOL
Piano in cristallo extralight / Piano girevole in cristallo blu grigio satinato / Base in cristallo temperato retroverniciato blu grigio satinato
Extralight glass top / Satin blue grey rotating plate / Blue grey satin tempered painted glass base

Yol

Oscar e Gabriele Buratti / 2013

Tavolo con piano in cristallo extralight 15mm, retroverniciato solo nella parte centrale nei colori del campionario nella versione brillante. In appoggio, piano girevole in cristallo 10mm temperato retroverniciato nei colori del campionario nella versione brillante o satinata. Base in legno rivestita in cristallo 6mm temperato retroverniciato.
Disponibile anche con piano completamente retroverniciato nei colori del campionario nella versione brillante o satinata.

! La retroverniciatura del piano nella parte centrale è realizzabile esclusivamente nella versione brillante.

Grazie al peso del cristallo il piano viene solo appoggiato sulla base e non necessita di fissaggio.

Table with 15mm extralight glass top, painted only in the middle part as per samples in the bright version. In the middle of the top rotating plate in 10mm tempered painted glass as per samples, in the bright or satin version. Wooden base covered by 6mm tempered painted glass.
Also available with completely painted glass top as per samples in the bright or satin version.

! The painting of the glass top in the middle part can only be done in the bright version.

Thanks to the weight of the glass, the top is only placed on the base and does not need to be fixed.



Cm
Ø 180 x 74
Ø 200 x 74
Ø 220 x 74
Ø 240 x 74

Inches
Ø 71" x 29¼"
Ø 78¾" x 29¼"
Ø 86¾" x 29¼"
Ø 94½" x 29¼"

[For technical drawing / p. 81](#)

[Pricelist 2023 / p. 33](#)

PIANO/TOP



Cristallo extralight
Extralight glass

BASE/BASE



Sample box

Cristallo brillante/satinato
nei colori del campionario
Glass bright/satin version
as per samples

PIANO E BASE/TOP AND BASE

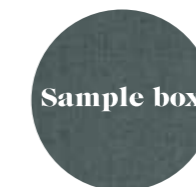

Sample box

Cristallo brillante/satinato
nei colori del campionario
Glass bright/satin version
as per samples

PIANO GIREVOLE / ROTATING PLATE



Sample box

Cristallo brillante/satinato
nei colori del campionario
Glass bright/satin version
as per samples

Yol Sect

Oscar e Gabriele Buratti / 2020

Tavolo con piano in legno o marmo diviso in quattro sezioni e girevole semi incassato in cristallo temperato 10mm con bisello da 35mm. Base in legno rivestita in cristallo 6mm temperato. Disponibile nelle combinazioni elencate.

! Il piano girevole è sporgente rispetto al piano di circa 5 millimetri.

NOTE TECNICHE SUI MATERIALI

CRISTALLO | Le finiture esclusive risultano dalla lavorazione manuale realizzata sul cristallo possono presentare striature e differenze cromatiche. Queste caratteristiche non devono essere considerate difetti ma elementi distintivi del processo artigianale che esaltano la bellezza e la peculiarità del pezzo unico.

MARMO | Il marmo è un materiale naturale di origine sedimentaria che può presentare particolarità come venature, lievi irregolarità superficiali, colorazioni differenti e cristallizzazioni. Queste peculiarità sono da attribuirsi alla naturalezza del materiale e non sono da considerarsi difetti ma caratteristiche tipiche del marmo. Ogni prodotto risulterà unico, esclusivo e non replicabile. I nostri marmi vengono trattati con un prodotto idrorepellente che permette una maggiore protezione della superficie stessa, aumentando l'impermeabilità. Questo trattamento non esclude la vulnerabilità del marmo alle sostanze acide.

Table with wooden or marble top divided into four sections and 10mm semi-recessed rotating tempered glass plate with 35mm bevel. Wooden base covered by 6mm tempered glass. Available in the combinations as per our list.

! The rotating plate is protruding from the top by about 5 millimeters.

TECHNICAL INFORMATION ON THE MATERIALS

GLASS | Exclusive finishes, resulting from the craftsmanship on the glass, may show streaks and chromatic differences. These characteristics should not be considered imperfections but distinctive evidence of the hand-made process that enhance the beauty and peculiarity of the unique piece.

MARBLE | The marble is a natural material of sedimentary origin that can present particularities such as veins, slight surface irregularities, different colors and crystallizations. These peculiarities are to be attributed to the naturalness of the material and are not to be considered defects but typical characteristics of marble. Each product will be unique, exclusive and non-replicable. Our marbles are treated with water-repellent products which affords greater protection to the surface of the marble, improving its impermeability. This treatment doesn't exclude the vulnerability of the marble to acid substances.

COMBINAZIONI COMBINATIONS

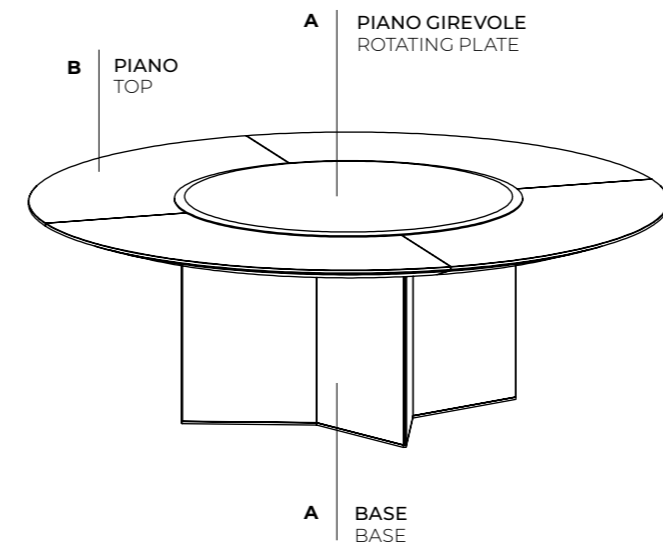

Le quattro sezioni del piano possono essere spostate per permettere la pulizia. The four sections of the top can be moved to allow cleaning.

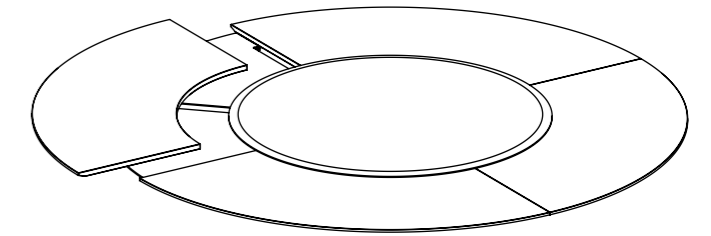

Cm

Ø 180 x 74
Ø 200 x 74
Ø 220 x 74
Ø 240 x 74

Inches

Ø 71" x 29¼"
Ø 78¾" x 29¼"
Ø 86¾" x 29¼"
Ø 94½" x 29¼"

[For technical drawing / p. 81](#)

[Pricelist 2023 / p. 34](#)

COMBINATION. A1

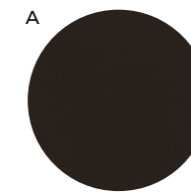

Cristallo retroverniciato nero satinato
Satin black painted glass

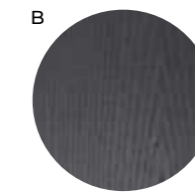

Frassino tinto nero poro aperto
Black open pore lacquered ash wood

COMBINATION. B4

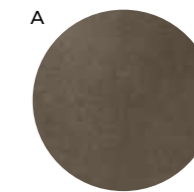

Cristallo verniciato bronzo antico
Antique bronze painted glass

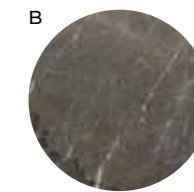

Marmo lucido naturale Stardust Grey
Natural polished Stardust Grey

COMBINATION. B1

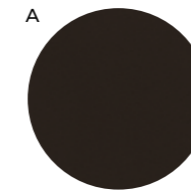

Cristallo retroverniciato nero satinato
Satin black painted glass

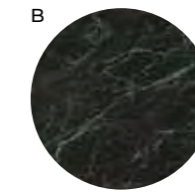

Marmo satinato Verde Alpi
Verde Alpi satin marble

COMBINATION. B5

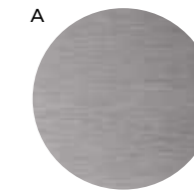

Cristallo verniciato "Cashmere" anthracite
"Cashmere" anthracite painted glass

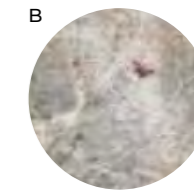

Marmo spazzolato Fior di Pesco
Fior di Pesco brushed marble

COMBINATION. B2

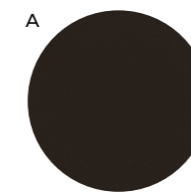

Cristallo retroverniciato nero satinato
Satin black painted glass

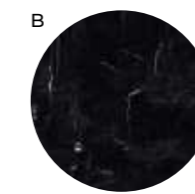

Marmo levigato opaco Nero Marquinia
Honed mat Nero Marquinia marble

COMBINATION. B6

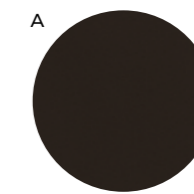

Cristallo verniciato piombo
Lead painted glass

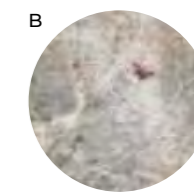

Marmo spazzolato Fior di Pesco
Fior di Pesco brushed marble

COMBINATION. B3

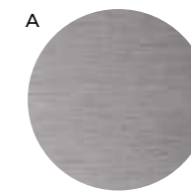

Cristallo verniciato "Cashmere" anthracite
"Cashmere" anthracite painted glass

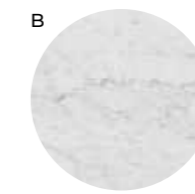

Marmo lucido naturale Bianco Carrara Gioia
Natural polished Bianco Carrara Gioia marble

COMBINATION. C1

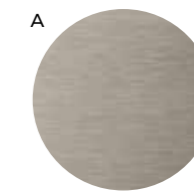

Cristallo verniciato "Cashmere" gold grey
"Cashmere" gold grey painted glass

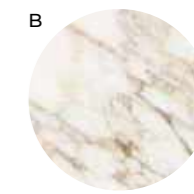

Marmo lucido naturale Calacatta Vagli Oro
Natural polished Calacatta Vagli Oro marble



COMBINATION. A1



COMBINATION. B1



COMBINATION. B2



COMBINATION. B3



COMBINATION. B4



COMBINATION. B5



COMBINATION. B6



COMBINATION. C1

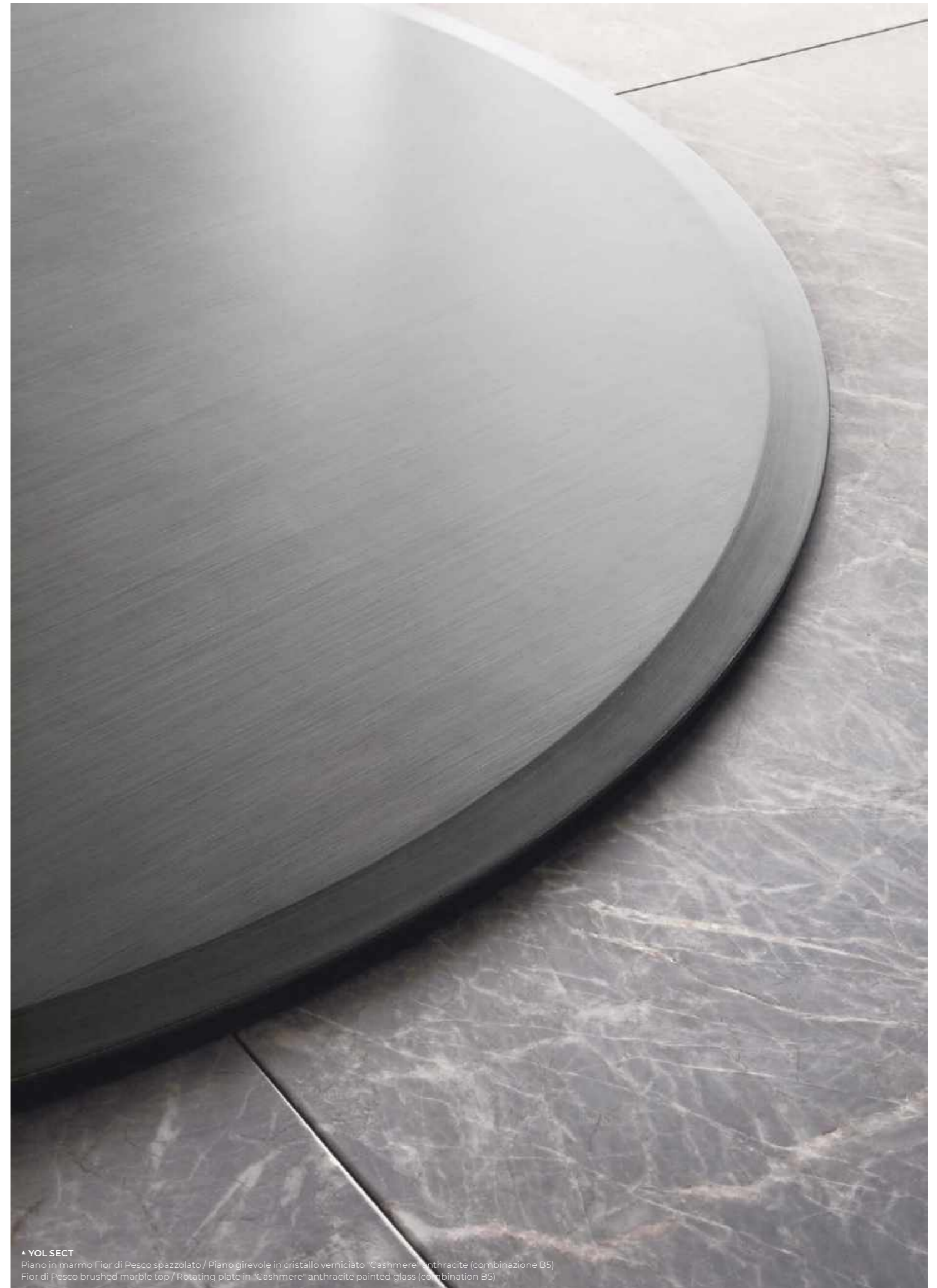

▲ YOL SECT
Piano in marmo Fior di Pesco spazzolato / Piano girevole in cristallo verniciato "Cashmere" antracite (combinazione B5)
Fior di Pesco brushed marble top / Rotating plate in "Cashmere" anthracite painted glass (combinazione B5)



▲ ZEN
Piano in frassino spazzolato tinto nero poro aperto / Piano in cristallo decorato a mano Craquelé
Black open pore brushed stained ash top / Hand-decorated Craquelé glass top

Zen

Massimo Castagna / 2018

Tavolo con piano in frassino spazzolato tinto nero poro aperto. Disponibile anche con piano in cristallo temperato 8mm decorato a mano nella finitura Craquelé. Base in alluminio spazzolato a mano e anodizzato nero con dettagli ottonati lucidi.

Table with black open pore brushed stained ash top. Also available with tempered hand-decorated Craquelé 8mm glass top. Black hand brushed anodised aluminium base with bright brass plated details.

NOTE TECNICHE SUI MATERIALI

CRISTALLO | Le finiture esclusive risultato della lavorazione manuale realizzata sul cristallo possono presentare striature e differenze cromatiche. Queste caratteristiche non devono essere considerate difetti ma elementi distintivi del processo artigianale che esaltano la bellezza e la peculiarità del pezzo unico.

TECHNICAL INFORMATION ON THE MATERIALS

GLASS | Exclusive finishes, resulting from the craftsmanship on the glass, may show streaks and chromatic differences. These characteristics should not be considered imperfections but distinctive evidence of the hand-made process that enhance the beauty and peculiarity of the unique piece.



Cm	Inches
A Ø 100 x 65	Ø 39½" x 25¾"
Ø 100 x 74	Ø 39½" x 29¼"
B-C-D 90 x 90 x 65	35½" x 35½" x 25¾"
90 x 90 x 74	35½" x 35½" x 29¼"

For technical drawing / p. 81

Pricelist 2023 / p. 36

PIANO/TOP

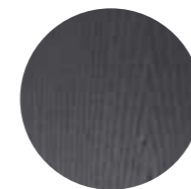

Frassino spazzolato tinto nero poro aperto
Black open pore brushed stained ash



Cristallo Craquelé
Craquelé glass

BASE/BASE

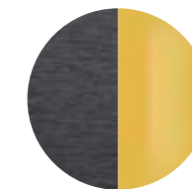

Alluminio spazzolato nero / Metallo ottonato lucido
Black brushed aluminium / Bright brassed metal



ZEN BLACK
 Piano in marmo lucido naturale Verde Alpi / Base in alluminio spazzolato anodizzato nero e metallo laccato nero
 Natural polished Verde Alpi marble top / Black hand brushed anodised aluminium base with black metal details

Zen Black

Massimo Castagna / 2020

Tavolo con piano in frassino spazzolato tinto nero poro aperto. Disponibile anche in cristallo temperato 8mm decorato a mano nella finitura Craquelé oppure in marmo 20mm Verde Alpi lucido naturale, Nero Marquinia levigato opaco, Fior di Pesco spazzolato o Bianco Carrara Gioia lucido naturale. Base in alluminio spazzolato a mano e anodizzato nero con dettagli in metallo laccato nero.

NOTE TECNICHE SUI MATERIALI

CRISTALLO | Le finiture esclusive risultato della lavorazione manuale realizzata sul cristallo possono presentare striature e differenze cromatiche. Queste caratteristiche non devono essere considerate difetti ma elementi distintivi del processo artigianale che esaltano la bellezza e la peculiarità del pezzo unico.

MARMO | Il marmo è un materiale naturale di origine sedimentaria che può presentare particolarità come venature, lievi irregolarità superficiali, colorazioni differenti e cristallizzazioni. Queste peculiarità sono da attribuirsi alla naturalezza del materiale e non sono da considerarsi difetti ma caratteristiche tipiche del marmo. Ogni prodotto risulterà unico, esclusivo e non replicabile. I nostri marmi vengono trattati con un prodotto idrorepellente che permette una maggiore protezione della superficie stessa, aumentando l'impermeabilità. Questo trattamento non esclude la vulnerabilità del marmo alle sostanze acide.

Table with black brushed open pore stained ash top. Also available with 8mm tempered hand-decorated Craquelé glass top or in 20mm natural polished Verde Alpi marble, honed mat Nero Marquinia marble, brushed Fior di Pesco marble, natural polished Bianco Carrara Gioia marble. Black hand brushed anodised aluminium base with black metal details.

TECHNICAL INFORMATION ON THE MATERIALS

GLASS | Exclusive finishes, resulting from the craftsmanship on the glass, may show streaks and chromatic differences. These characteristics should not be considered imperfections but distinctive evidence of the hand-made process that enhance the beauty and peculiarity of the unique piece.

MARBLE | The marble is a natural material of sedimentary origin that can present particularities such as veins, slight surface irregularities, different colors and crystallizations. These peculiarities are to be attributed to the naturalness of the material and are not to be considered defects but typical characteristics of marble. Each product will be unique, exclusive and non-replicable. Our marbles are treated with water-repellent products which affords greater protection to the surface of the marble, improving its impermeability. This treatment doesn't exclude the vulnerability of the marble to acid substances.



Cm

Ø 100 x 65
 Ø 100 x 74
 Ø 120 x 65
 Ø 120 x 74

Inches

Ø 39½" x 25¾"
 Ø 39½" x 29¼"
 Ø 47¼" x 25¾"
 Ø 47¼" x 29¼"

For technical drawing / p. 82

Pricelist 2023 / p. 37

PIANO/TOP

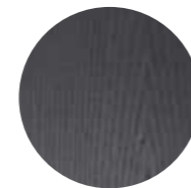

Frassino spazzolato tinto nero poro aperto
 Black open pore brushed stained ash



Cristallo Craquelé
 Craquelé glass



Marmo lucido naturale Bianco Carrara Gioia
 Natural polished Bianco Carrara Gioia marble



Marmo spazzolato Fior di Pesco
 Fior di Pesco brushed marble



Marmo levigato opaco Nero Marquinia
 Honed mat Nero Marquinia marble

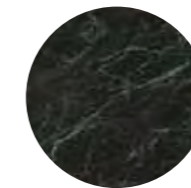

Marmo lucido naturale Verde Alpi
 Natural polished Verde Alpi marble

BASE/BASE

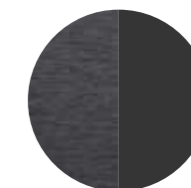

Alluminio spazzolato e anodizzato nero/ Metallo laccato nero
 Hand brushed anodised aluminium / Black metal details



• **LAZY SUSAN**
Piano girevole in cristallo extralight con parte centrale retroverniciata nero brillante
Rotating plate in extralight glass with bright black painted central part

Lazy Susan

Studio G&R / 1986

Piano girevole in cristallo extralight 10mm molato a bisello (10mm) con parte centrale retroverniciata nei colori del campionario nella versione brillante. Disponibile versione completamente retroverniciata nei colori del campionario nella versione brillante o satinata. Può essere appoggiato su qualsiasi piano.

! Nella versione con parte centrale retroverniciata la retroverniciatura è realizzabile esclusivamente nella versione brillante.

Rotating plate in 10mm extralight glass with bevelled edge (10mm). Painted glass central part as per sample in the bright version. Also available version completely painted as per samples in the bright or satin version. It can be placed on any top.

! In the painted glass central part version the painting in the middle part can only be done in the bright version.



Cm	Inches
Ø 70	Ø 27¾"
Ø 75	Ø 29¾"
Ø 80	Ø 31½"
Ø 85	Ø 33½"
Ø 90	Ø 35½"
Ø 95	Ø 37½"
Ø 100	Ø 39½"

[For technical drawing / p. 82](#)

[Pricelist 2023 / p. 192](#)

PIANO GIREVOLE E PARTE CENTRALE ROTATING PLATE/CENTRAL PART



Cristallo extralight/Cristallo retroverniciato
brillante nei colori del campionario
Extralight glass/Bright
painted glass as per samples

PIANO GIREVOLE/ROTATING PLATE

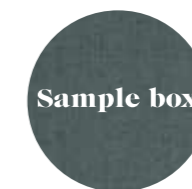

Cristallo retroverniciato brillante/satinato
nei colori del campionario
Bright/satin painted glass
as per samples

01

Tavoli / Tables
TECHNICAL MODULE

Adam | Studio G&R, 1971

Product information / p. 8

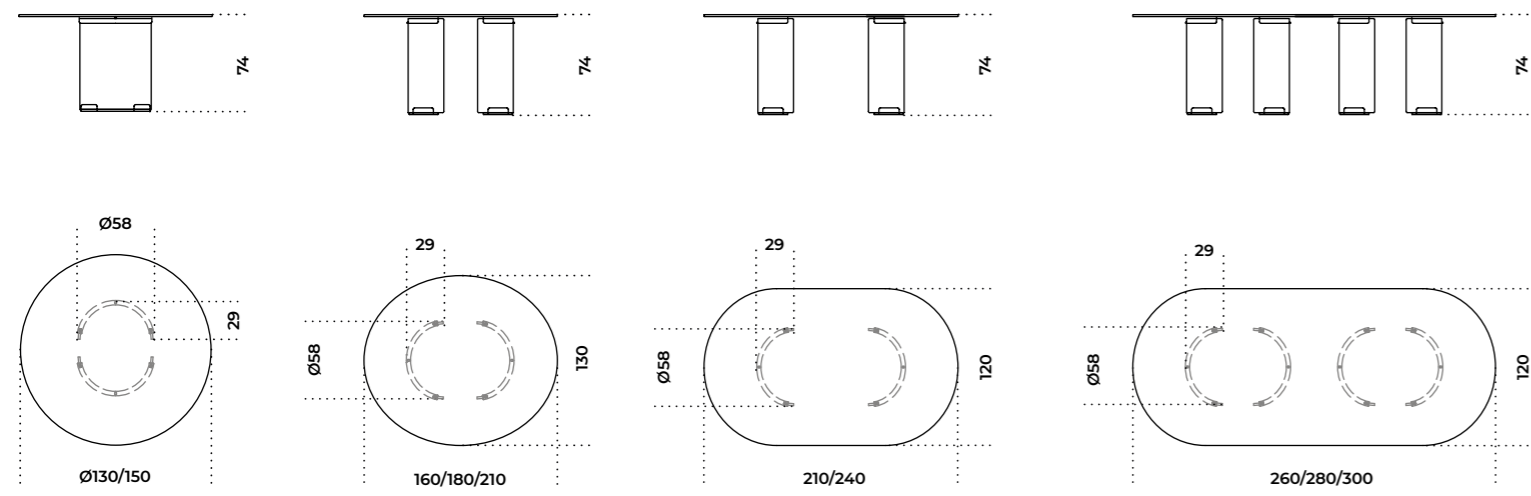

Dolm Plus | Oscar e Gabriele Buratti, 2019

Product information / p. 14

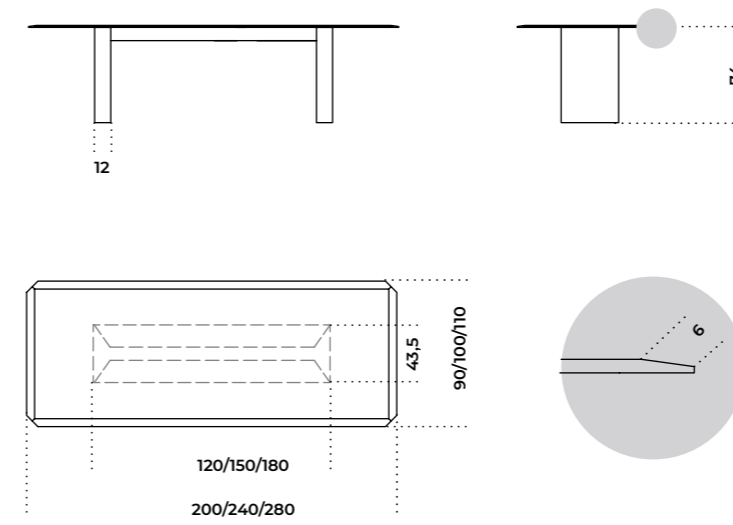

Clemo - T | Massimo Castagna, 2022

Product information / p. 10

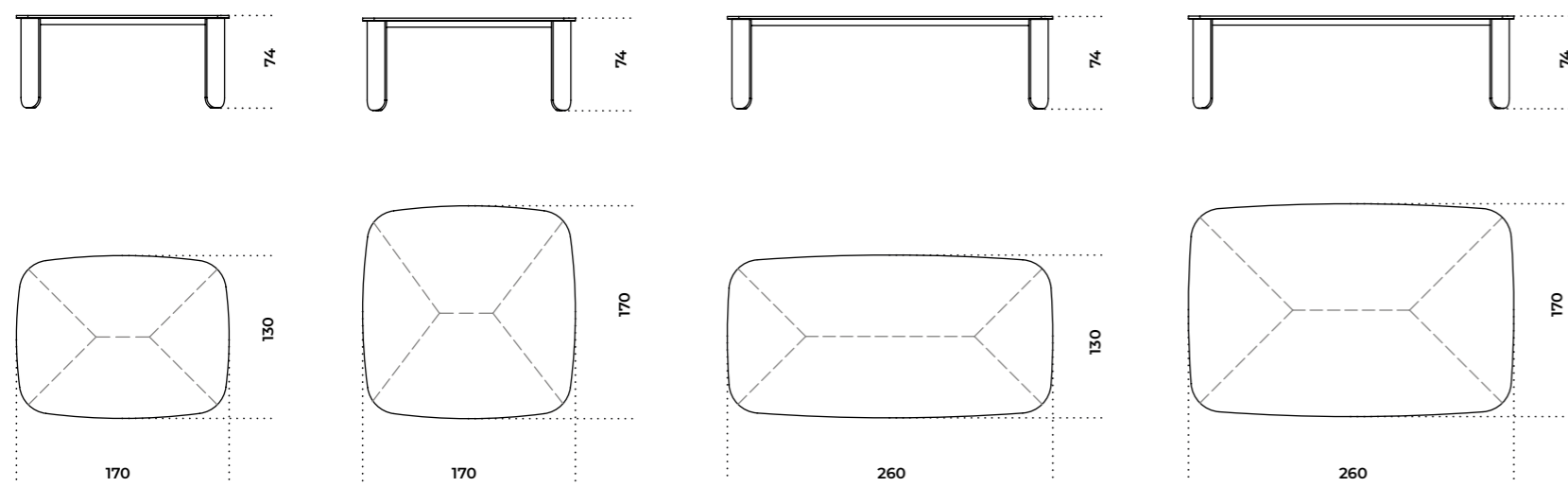

Eros | Pierangelo Gallotti, 1971

Product information / p. 16

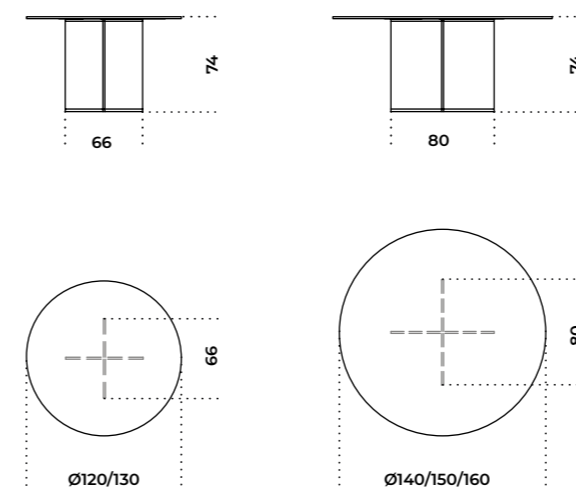

Dolm | Oscar e Gabriele Buratti, 2012

Product information / p. 12

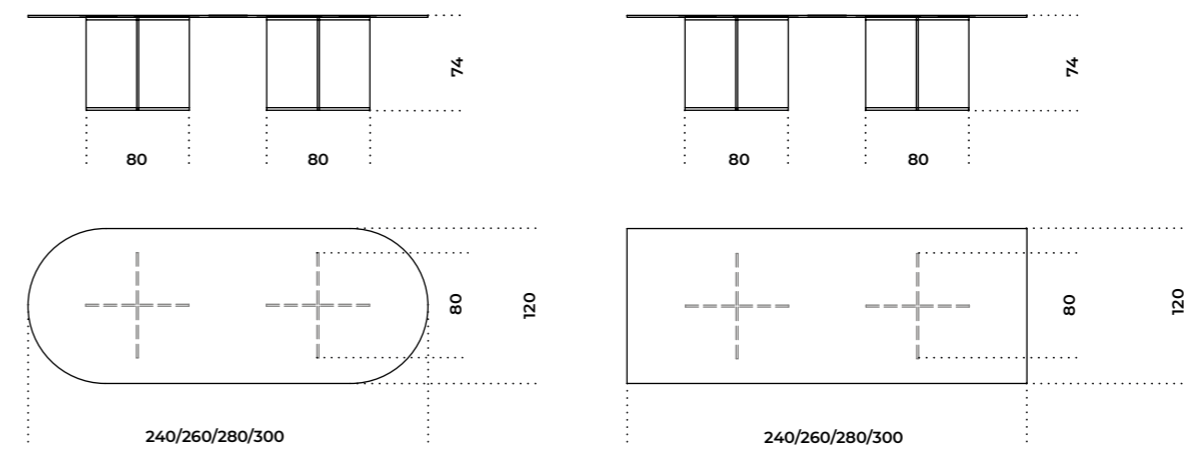
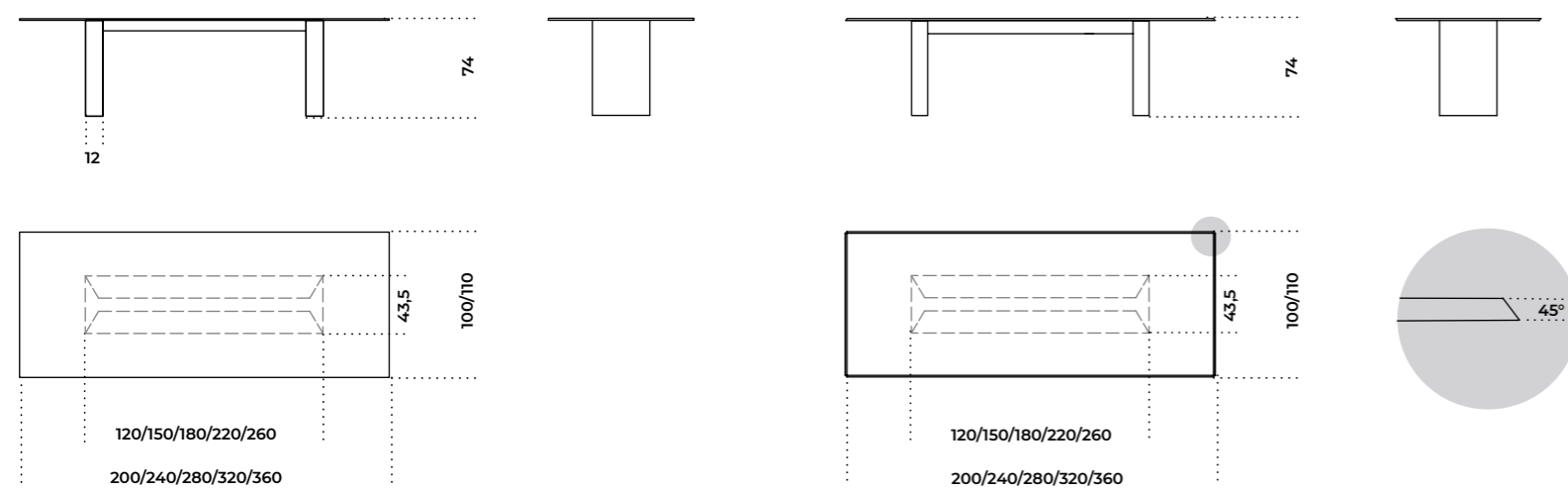

Piano bisellato
Bevelled glass top

Eyl | Oscar e Gabriele Buratti, 2014

Product information / p. 18

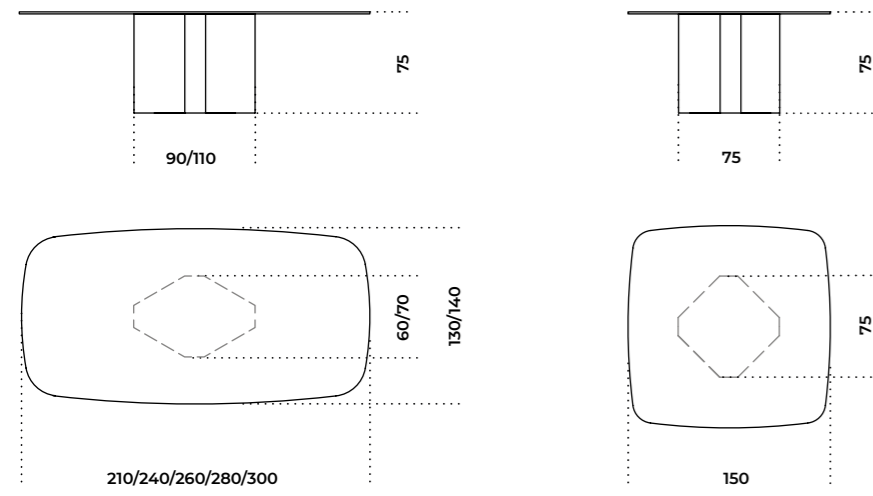

Maat | Pietro Russo, 2017

Product information / p. 24

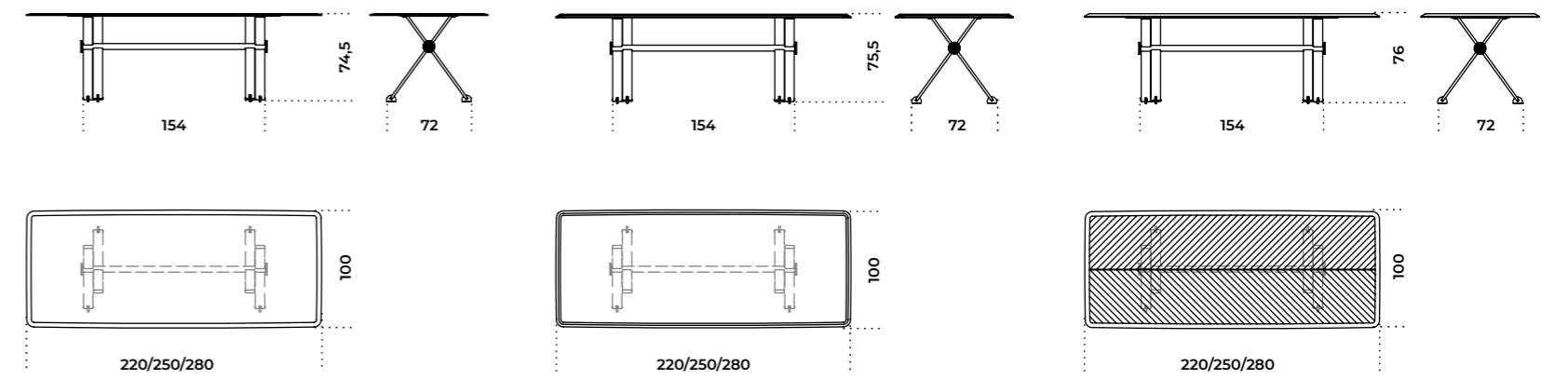

Piano in cristallo
Glass top

Piano in marmo
Marble top

Piano in legno intarsiato
Inlaid wooden top

Haumea - T | Massimo Castagna, 2016

Product information / p. 20

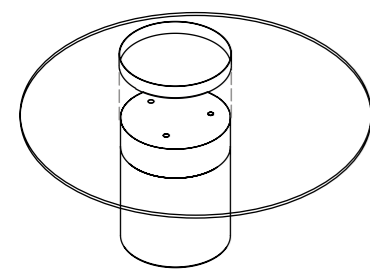
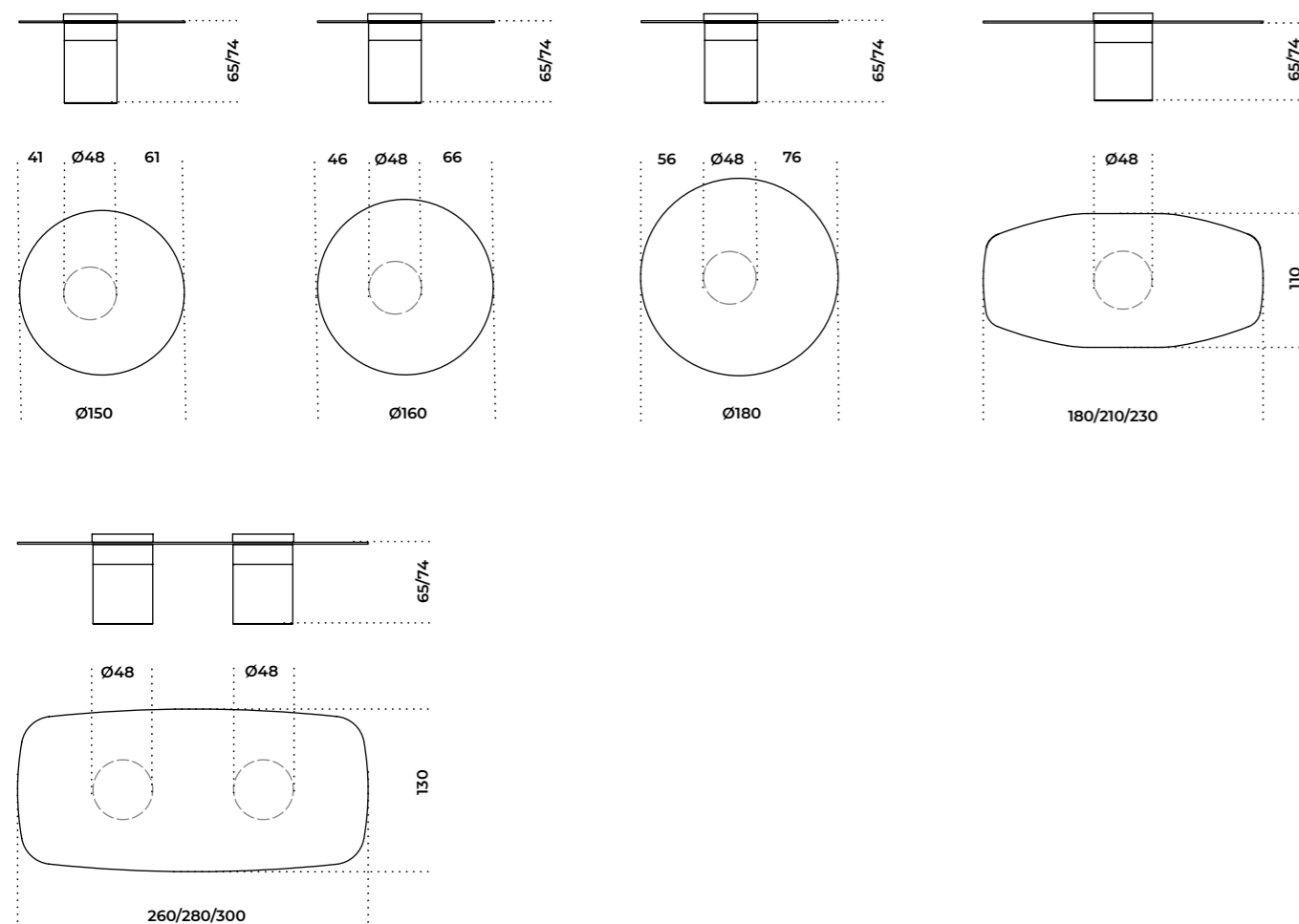

Nella versione con un basamento il piano è fissato alla base.
In the version with one base the top is fixed.

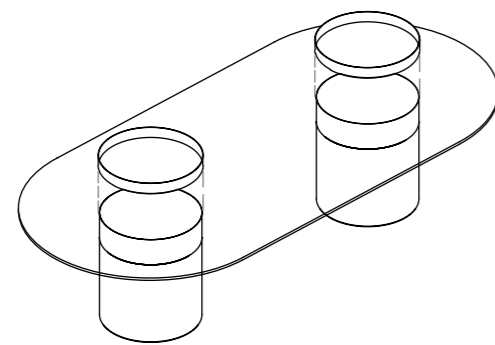

Nella versione con due basamenti il piano è solo in appoggio.
In the version with two bases the top is just resting.

Manto | Pietro Russo, 2020

Product information / p. 28

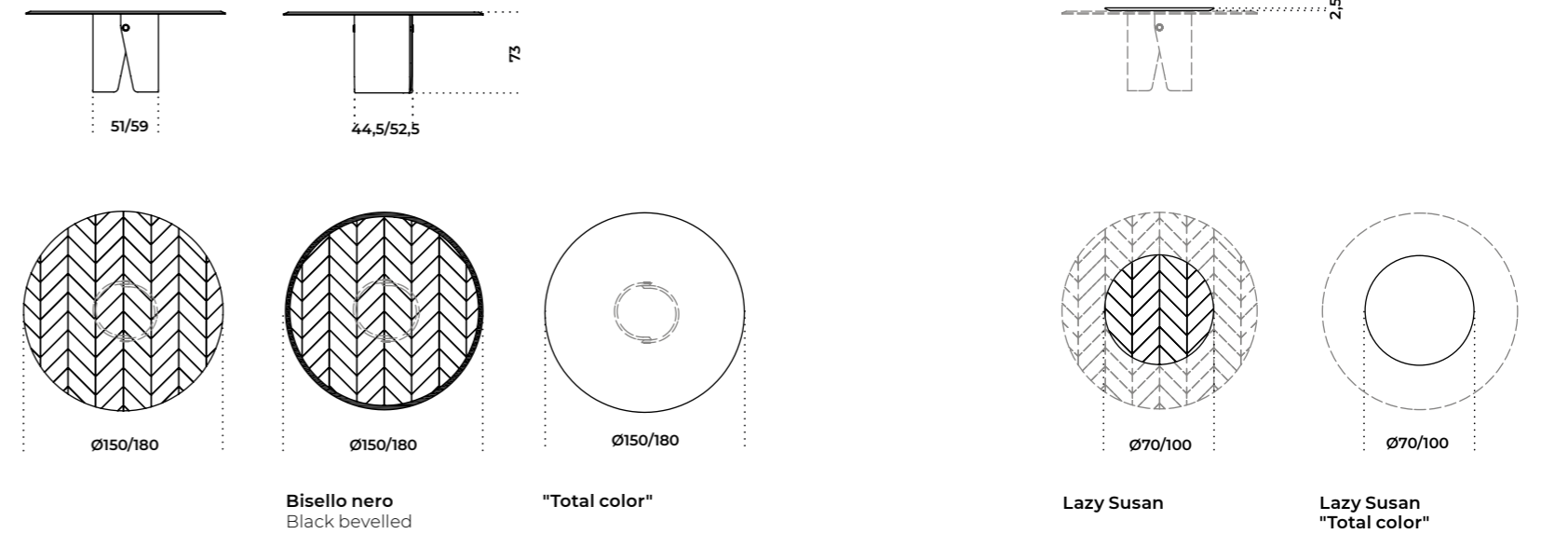

Bisello nero
Black bevelled

"Total color"

Lazy Susan

Lazy Susan
"Total color"

Manto Oval | Pietro Russo, 2021

Product information / p. 32

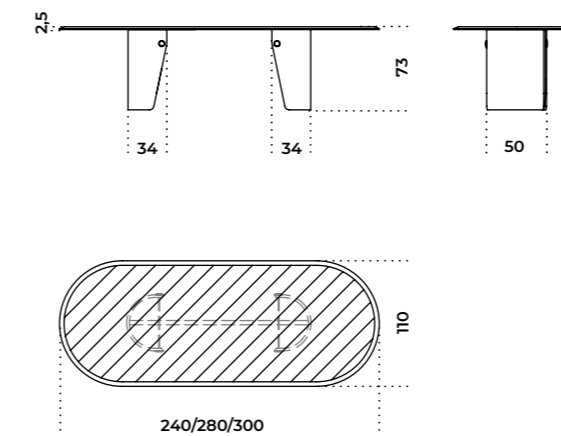

Oto | Oscar e Gabriele Buratti, 2015

Product information / p. 34

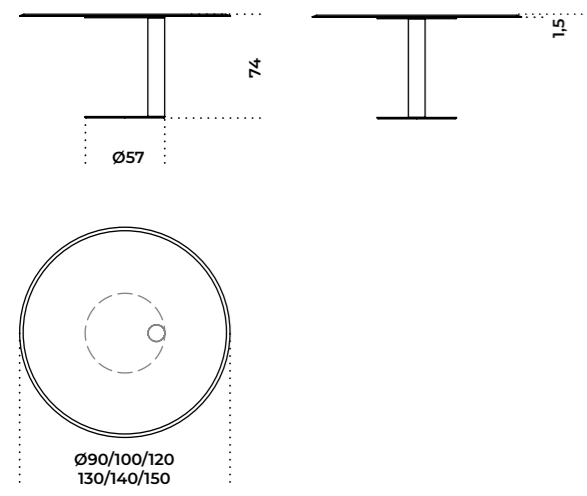

Platium | Oscar e Gabriele Buratti, 2016

Product information / p. 40

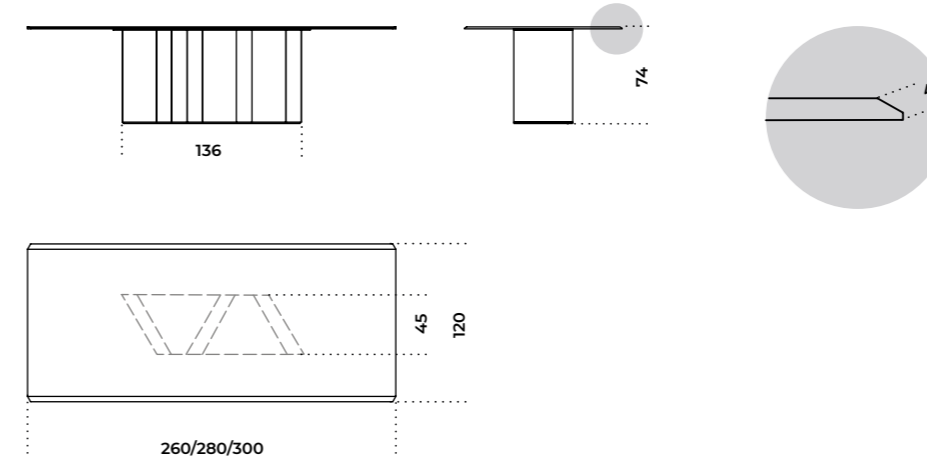

Oto Big | Oscar e Gabriele Buratti, 2018

Product information / p. 36

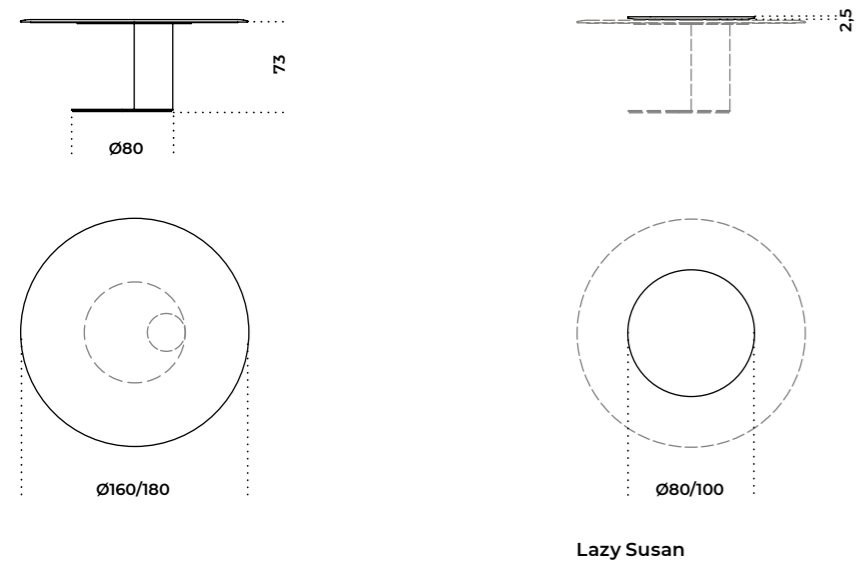

Platium Round | Oscar e Gabriele Buratti, 2018

Product information / p. 42

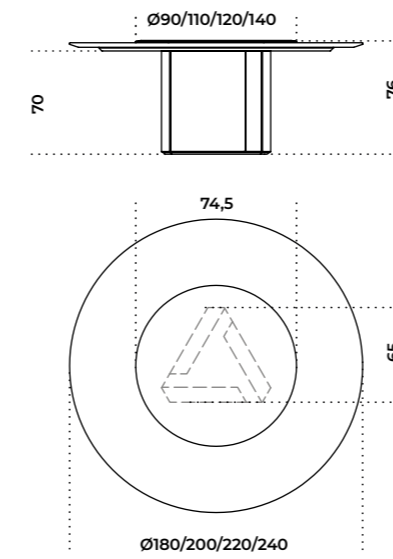

Oto Medium | Oscar e Gabriele Buratti, 2022

Product information / p. 38

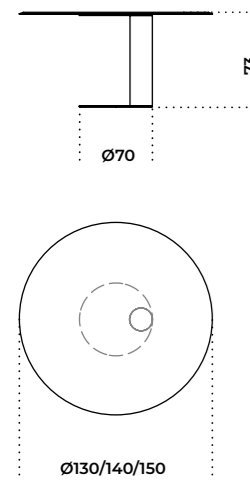

Platium System | Oscar e Gabriele Buratti, 2018

Product information / p. 44

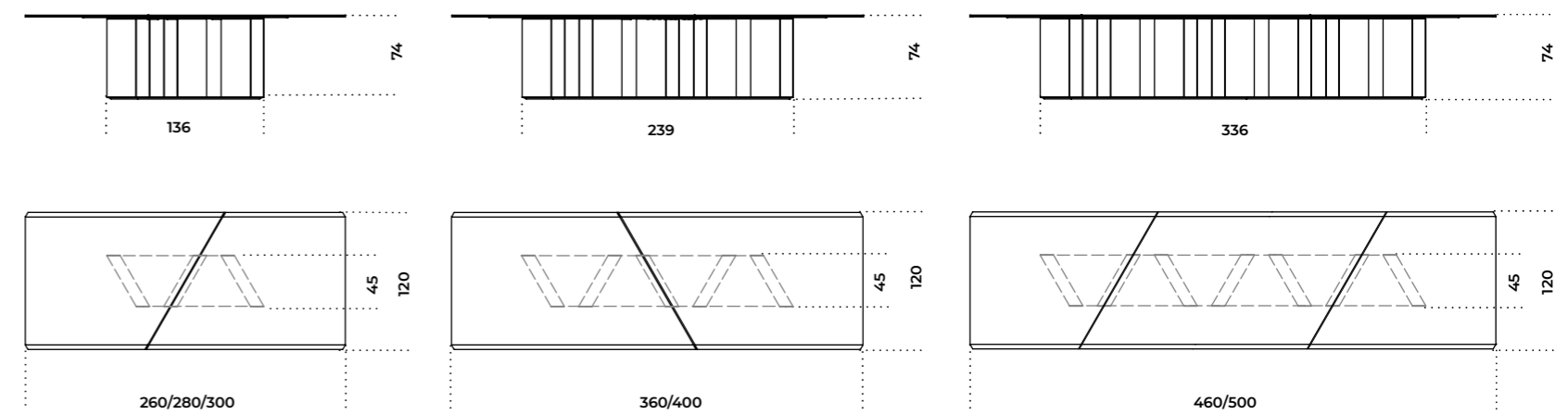

Platium W | Oscar e Gabriele Buratti, 2017

Product information / p. 46

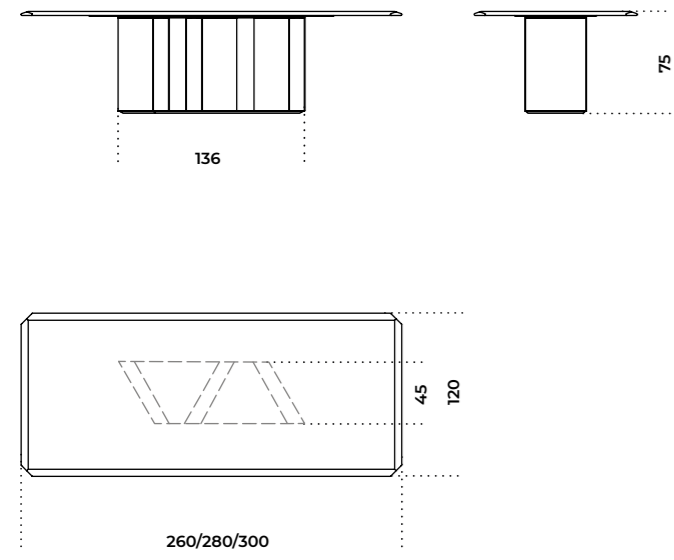

Shiro | Oscar e Gabriele Buratti, 2021

Product information / p. 50

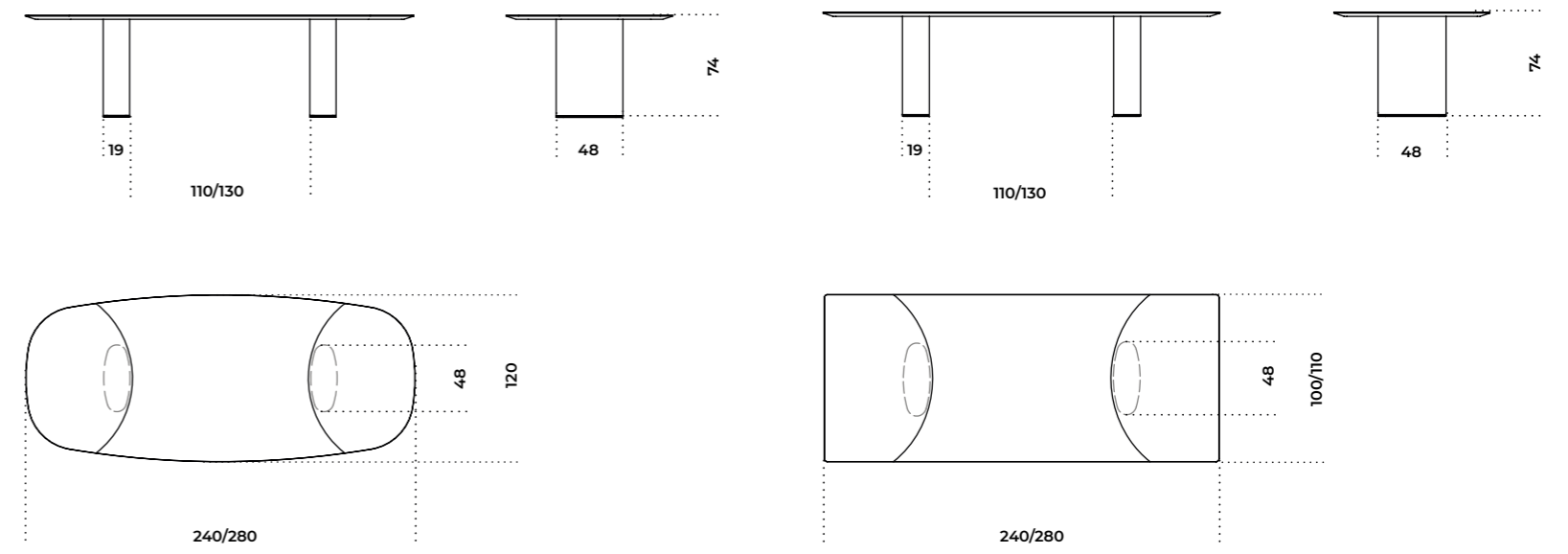

Prism | david/nicolas, 2019

Product information / p. 48

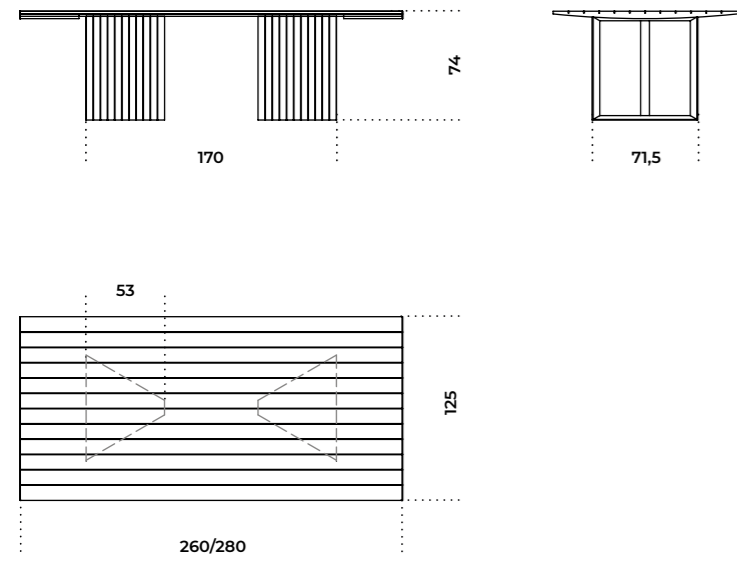

Simpòdio | Pinuccio Borgonovo, 2022

Product information / p. 52

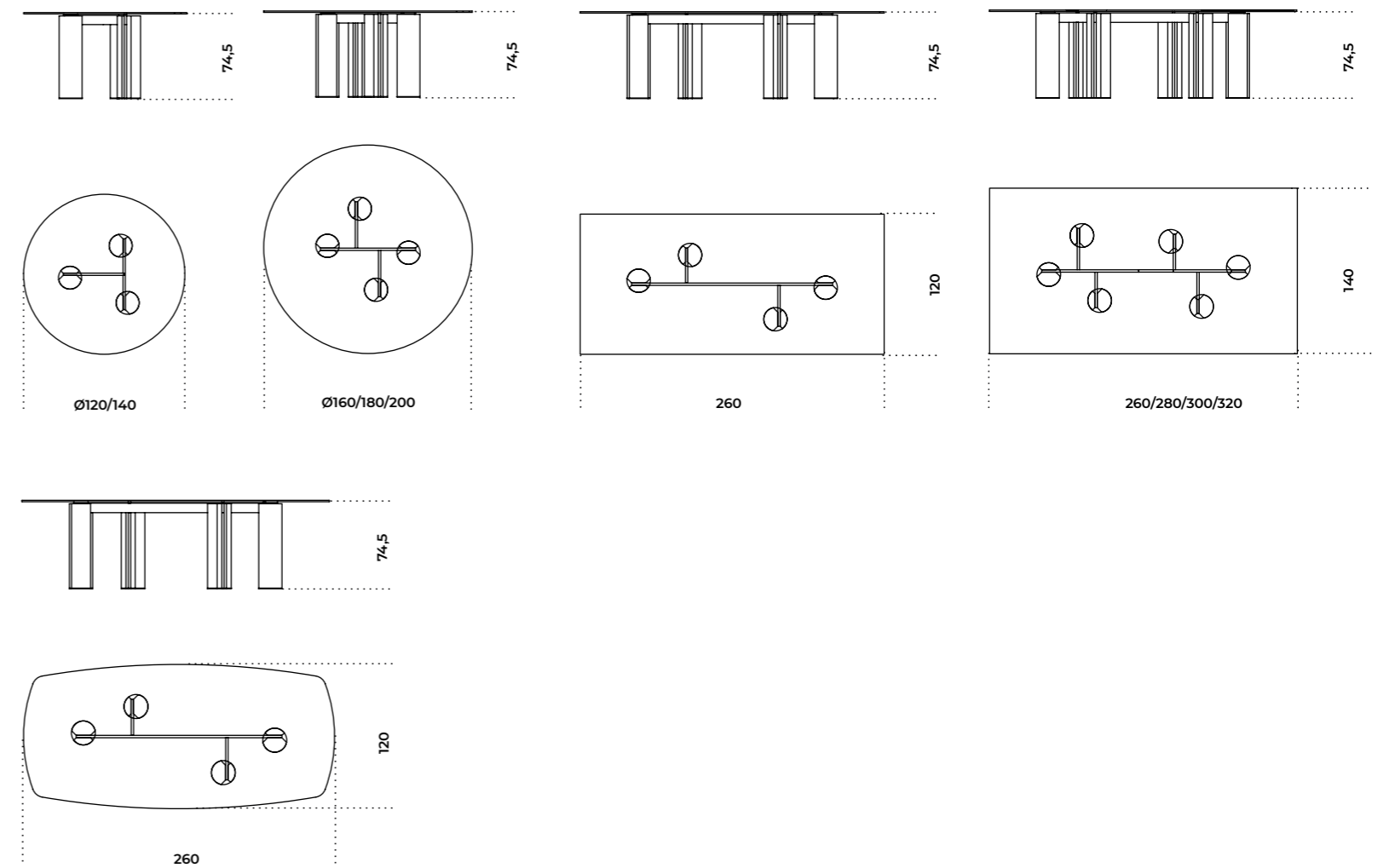

Simpòdio System | Pinuccio Borgonovo, 2022

Product information / p.54

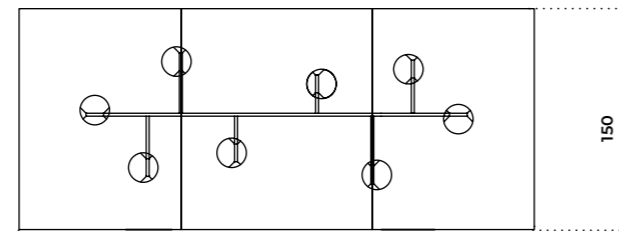
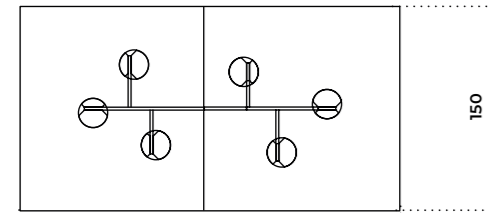
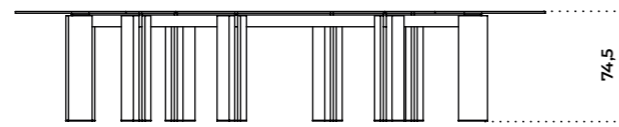
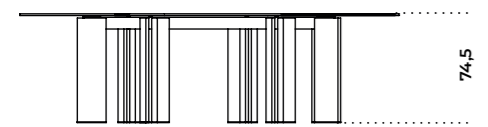

260/280/300/320

350/390/430

Piano in cristallo
Glass top

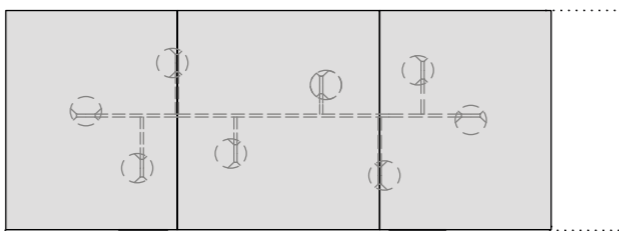
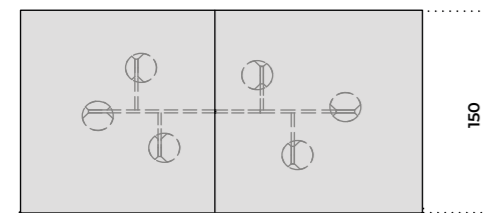
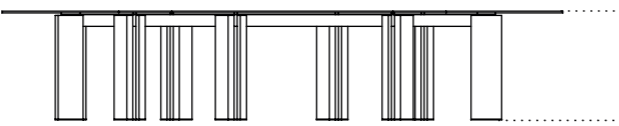
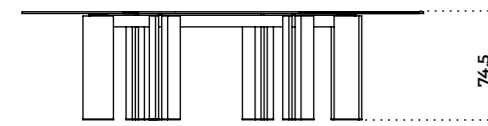

260/280/300/320

350/390/430

Piano in cristallo verniciato bronzo antico/piombo
Antique bronze/lead painted glass top

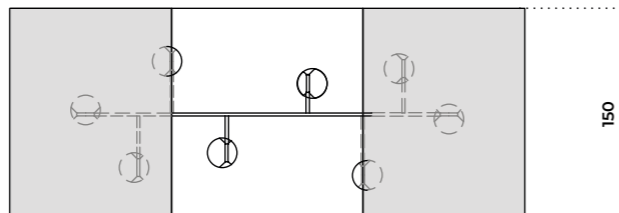
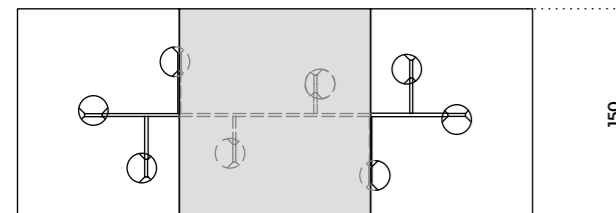
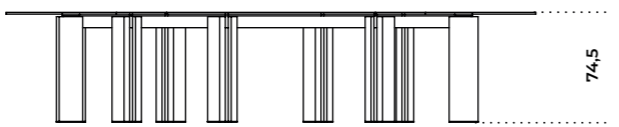
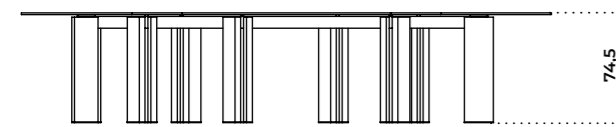

350/390/430

350/390/430

Versione con un piano verniciato e due extrilight
Version with one painted glass top and two extrilight glass tops

Versione con due piani verniciati e uno extrilight
Version with two painted glass tops and one extrilight glass top

Yo! | Oscar e Gabriele Buratti, 2013

Product information / p.56

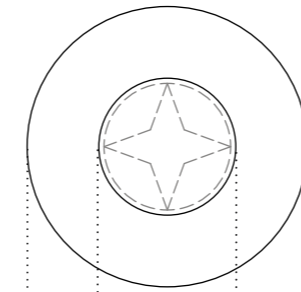
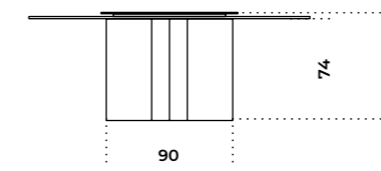

Ø96
Ø180/200/220/240

Yo! Sect | Oscar e Gabriele Buratti, 2020

Product information / p.58

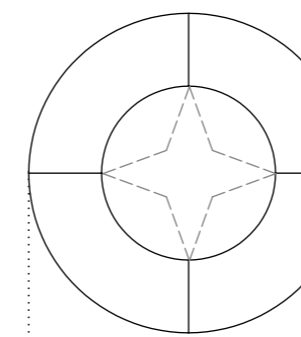
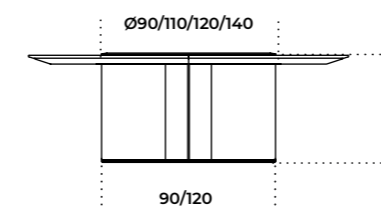

Ø180/200/220/240

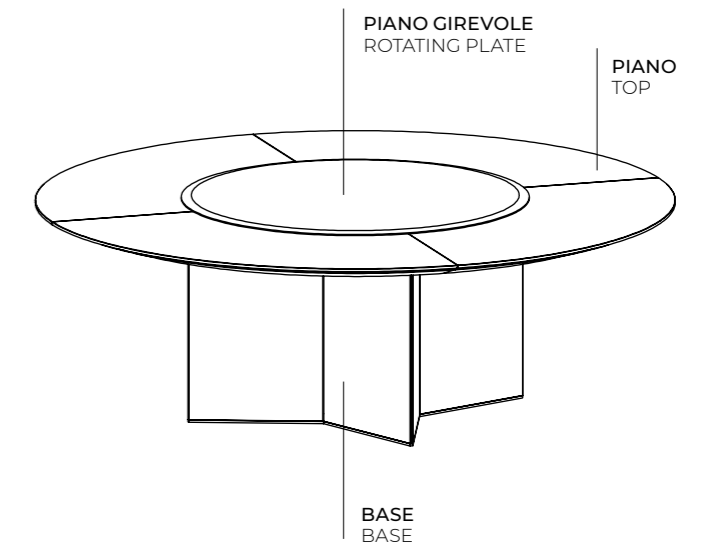

Zen | Massimo Castagna, 2018

Product information / p.62

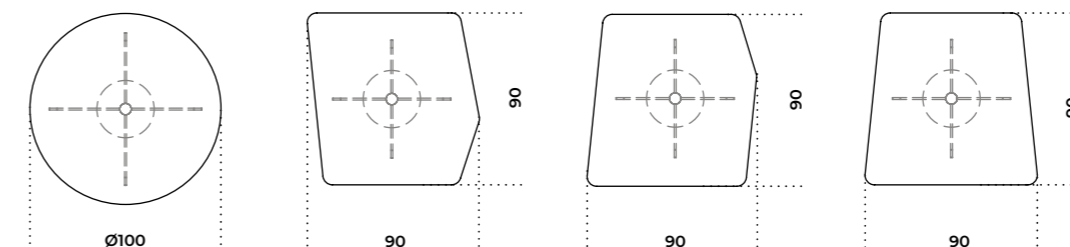
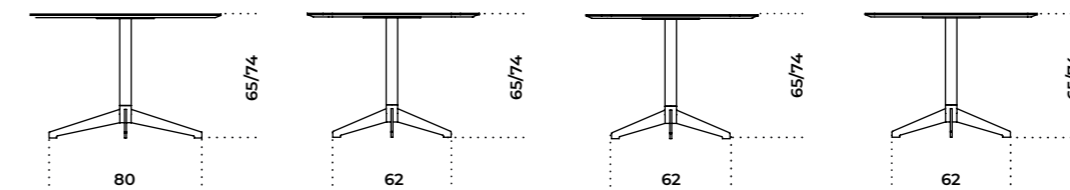

A

B

C

D

Zen Black | Massimo Castagna, 2020

Product information / p. 64

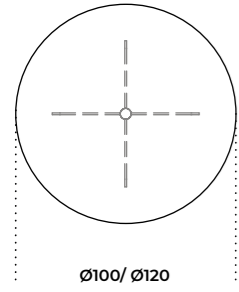
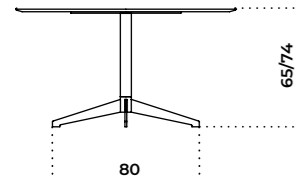

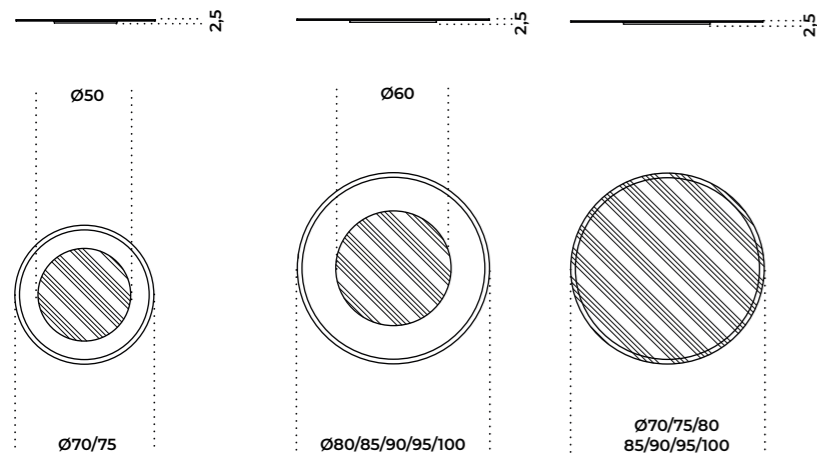

Lazy Susan | Studio G&R, 1986

Product information / p. 66



 **Cristallo retroverniciato brillante**
Bright painted glass

 **Cristallo retroverniciato satinato**
Satin painted glass
 **Cristallo retroverniciato brillante**
Bright painted glass

02 Sedute / Seatings

<u>86</u>	<u>0414</u>
<u>88</u>	<u>0419</u>
<u>90</u>	<u>Akiko</u>
<u>92</u>	<u>Jackie</u>
<u>94</u>	<u>Janette</u>
<u>96</u>	<u>Keyko</u>
<u>98</u>	<u>Livrette</u>
<u>100</u>	<u>Thea</u>
<u>102</u>	<u>Thea Queen</u>
<u>104</u>	<u>Informazioni tecniche/ Technical informations</u>

0414

Studio G&R / 2014

Poltroncina con struttura in massello di frassino curvato tinto nero poro aperto. Disponibile anche in frassino naturale, tinto tabacco, tinto bianco poro aperto o tinto grigio smoke poro aperto. Seduta e schienale con struttura interna in legno e derivati con imbottitura in poliuretano espanso indeformabile a densità differenziate. Rivestimento in tessuto o pelle nei colori del campionario.

! Non sfoderabile.

Per la realizzazione di elementi con rivestimento in pelle sono necessarie cuciture aggiuntive rispetto gli elementi con rivestimento in tessuto.

Il massello di frassino naturale presenta variazioni di colore che vanno dal biondo chiaro al rosa fino ad arrivare al bruno pallido, con eventuali sfumature di verde. Queste differenze sono da considerarsi caratteristiche di questa essenza.

Il legno massello è molto sensibile alla luce, il posizionamento vicino a sorgenti di luce naturale ne compromette la colorazione e la stabilità. Un'elevata variazione della temperatura e umidità dell'aria può provocare la comparsa di microfratture e leggere variazioni.

Armchair with black stained open pore solid curved ash structure. Also available in natural ash, tobacco stained, white open pore stained or grey smoke open pore stained ash. Seat and backrest with internal structure in wood and by-products with padding in non-deformable foam polyurethane in different densities. Covered by fabric or leather as per samples.

! Not removable cover.

Additional stitching is required for elements with leather upholstery compared to elements with fabric upholstery.

Natural ash solid wood has colour variations ranging from light blonde to pink to pale brown, with possible shades of green. These differences are to be considered characteristic of this essence.

Solid wood is very light-sensitive, placing it near natural light sources may compromise its colour and stability. Considerable differences in air temperature and humidity may cause microfractures and slight variations.



Cm
57 x 52 x 75

Inches
22½" x 20½" x 29¾"

For technical drawing / p. 108

Pricelist 2023 / p. 41
Homescapes, sense of materials / pp. 60, 96
Homescapes, embracing beauty / pp. 41, 75
Homescapes, intimate portraits / pp. 40, 46
Homescapes, gentle attitude / pp. 15, 17, 81, 83

STRUTTURA/STRUCTURE

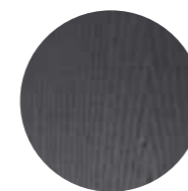

Frassino tinto
nero poro aperto
Black stained
open pore ash

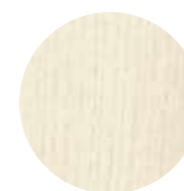

Frassino naturale
Natural ash

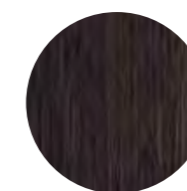

Frassino tinto tabacco
Tobacco stained ash

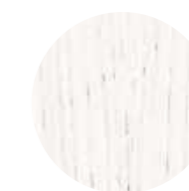

Frassino tinto
bianco poro aperto
White open pore
stained ash



Frassino tinto
grigio smoke poro aperto
Grey smoke open pore
stained ash



Sample box
COVERS

Tessuto/pelle nei colori del
campionario
Fabric/leather as per
samples.

▲ 0414
Struttura in frassino tinto nero poro aperto / Rivestimento in velvet Mink 518
Black lacquered open pore solid ash structure / Cover in velvet Mink 518



0419

Studio G&R / 2019

Sgabello con struttura in massello di frassino curvato tinto nero poro aperto e poggiatesta in metallo laccato grigio antracite. Disponibile anche in frassino naturale, tinto tabacco, tinto bianco poro aperto o tinto grigio smoke poro aperto. Seduta e schienale con struttura interna in legno e derivati con imbottitura in poliuretano espanso indeformabile a densità differenziate. Rivestimento in tessuto o pelle nei colori del campionario.

! Non sfoderabile.

Per la realizzazione di elementi con rivestimento in pelle sono necessarie cuciture aggiuntive rispetto gli elementi con rivestimento in tessuto.

Il massello di frassino naturale presenta variazioni di colore che vanno dal biondo chiaro al rosa fino ad arrivare al bruno pallido, con eventuali sfumature di verde. Queste differenze sono da considerarsi caratteristiche di questa essenza.

Il legno massello è molto sensibile alla luce, il posizionamento vicino a sorgenti di luce naturale ne compromette la colorazione e la stabilità. Un'elevata variazione della temperatura e umidità dell'aria può provocare la comparsa di microfessure e leggere variazioni.

Stool with black stained open pore solid curved ash structure and anthracite grey lacquered metal footrest. Also available in natural ash, tobacco stained, white open pore stained or grey smoke open pore stained ash. Seat and backrest with internal structure in wood and byproducts with padding in non-deformable foam polyurethane in different densities. Covered by fabric or leather as per samples.

! Not removable cover.

Additional stitching is required for elements with leather upholstery compared to elements with fabric upholstery.

Natural ash solid wood has colour variations ranging from light blonde to pink to pale brown, with possible shades of green. These differences are to be considered characteristic of this essence.

Solid wood is very light-sensitive, placing it near natural light sources may compromise its colour and stability. Considerable differences in air temperature and humidity may cause microfractures and slight variations.



Cm

57 x 52 x 92
57 x 52 x 102

Inches

22½" x 20¼" x 36¼"
22½" x 20¼" x 40¼"

[For technical drawing / p.108](#)

[Pricelist 2023 / p. 42](#)

STRUTTURA/STRUCTURE

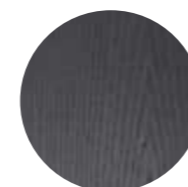

**Frassino tinto
nero poro aperto**
Black stained
open pore ash

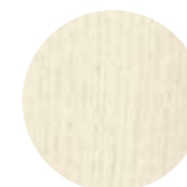

Frassino naturale
Natural ash

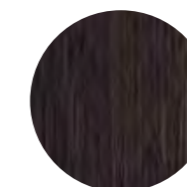

**Frassino tinto
tabacco**
Tobacco stained ash



**Frassino tinto
bianco poro aperto**
White open pore
stained ash



**Frassino tinto
grigio smoke poro aperto**
Grey smoke open pore
stained ash



**Metallo laccato
grigio antracite**
Anthracite grey
lacquered metal

RIVESTIMENTO/COVER



**Sample box
COVERS**
Tessuto/pelle nei colori del
campionario
Fabric/leather as per
samples.

▲ 0419

Struttura in frassino tinto nero poro aperto / Rivestimento in leather Tobacco 013
Black lacquered open pore solid ash structure / Cover in leather Tobacco 013

Akiko

Oscar e Gabriele Buratti / 2021



Sedia con struttura interna in legno imbottita con poliuretano espanso indeformabile a densità differenziate e fibra poliestere. Basamento in metallo verniciato color "warm grey". Rivestimento in tessuto o pelle nei colori del campionario.
Non sfoderabile.
Disponibile versione con movimento girevole a 180° con ritorno con basamento a 4 razze in metallo verniciato color "warm grey" con finalini.

! Non sfoderabile.

Per la realizzazione di elementi con rivestimento in pelle sono necessarie cuciture aggiuntive rispetto gli elementi con rivestimento in tessuto.

Chair with inside structure in wood padded with non-deformable polyurethane foam in different density and polyester fibre. Metal base lacquered in "warm grey" colour. Covered by fabric or leather as per samples.
Not removable cover.

Also available version with 180°swivel movement with return with "warm grey" colour lacquered four star metal base with feet.

! Not removable cover.

Additional stitching is required for elements with leather upholstery compared to elements with fabric upholstery.



Cm
59 x 57 x 77

Inches
23¼" x 22½" x 30½"

For technical drawing / p.108

Pricelist 2023 / p. 43
Homescapes, intimate portraits / pp. 82, 85
Homescapes, gentle attitude / pp. 28, 30, 34, 45, 90

**BASE METALLICA/
METAL BASE**



Metallo verniciato
"warm grey"
Metal lacquered
"warm grey" colour

RIVESTIMENTO/COVER



Tessuto/pelle nei colori del
campionario
Fabric/leather as per
samples.



Jackie

Stefano Bigi / 2014

Sedia con struttura interna in legno e derivati imbottita con poliuretano espanso indeformabile a densità differenziate e fibra poliestere. Disponibile versione con braccioli. Completamente rivestita in tessuto o in pelle nei colori del campionario. A richiesta versione con gambe in frassino laccato nero poro aperto. Disponibile versione "loungè" (solo per poltroncina) con altezza della seduta 40cm.

Upholstered chair with inside structure in wood and by-products. Padded with non-deformable polyurethane foam in different density and polyester fibre. Available version with armrests. Completely covered by fabric or leather as per samples. On request version with black open pore lacquered ash legs. Also available "loungè" version (only for armchair) with seat's height cm 40.

! Non sfoderabile.

Per la realizzazione di elementi con rivestimento in pelle sono necessarie cuciture aggiuntive rispetto gli elementi con rivestimento in tessuto.

! Not removable cover.

Additional stitching is required for elements with leather upholstery compared to elements with fabric upholstery.



Cm
54 x 56 x 80
54 x 56 x 73 (loungè)

Inches
21½" x 22¼" x 31½"
21½" x 22¼" x 28¾"

[For technical drawing / p. 109](#)

[Pricelist 2023 / p. 44](#)
[Homescapes, embracing beauty / pp. 15, 48](#)

RIVESTIMENTO/COVER



Tessuto/pelle nei colori del campionario
Fabric/leather as per samples.

STRUTTURA/STRUCTURE



Tessuto/pelle nei colori del campionario
Fabric/leather as per samples.

GAMBE/LEGS

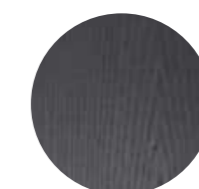

Frassino laccato nero poro aperto
Black lacquered open pore ash



Janette

Federica Biasi / 2023

Poltroncina con struttura interna in legno imbottita con poliuretano espanso indeformabile a densità differenziate e fibra poliestere. Completamente rivestita in tessuto o in pelle nei colori del campionario. Zoccolo in metallo nichelato nero.

Armchair with inside structure in wood padded with non-deformable polyurethane foam in different density and polyester fibre. Completely covered by fabric or leather as per samples. Plinth in black nickel-plated metal.

! Non sfoderabile.

Per la realizzazione di elementi con rivestimento in pelle sono necessarie cuciture aggiuntive rispetto gli elementi con rivestimento in tessuto.

! Not removable cover.

Additional stitching is required for elements with leather upholstery compared to elements with fabric upholstery.



Cm
70 x 57 x 78,5

Inches
27¾" x 22½" x 31

[For technical drawing / p.109](#)

[Pricelist 2023 / p. 48](#)
[Homescapes, embracing beauty / pp. 15, 48](#)

RIVESTIMENTO/COVER



Tessuto/pelle nei colori del campionario
Fabric/leather as per samples.

ZOCCOLO/PLINTH

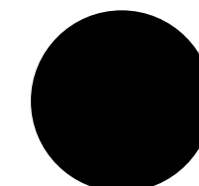

Metallo nichelato nero
Black nickel-plated metal



• **KEYKO**
Struttura in frassino tinto nero poro aperto / Rivestimento in Tokyo tabacco 203
Black lacquered open pore ash structure / Cover in Tokyo tabacco 203

Keyko

Pinuccio Borgonovo / 2017

Sedia con struttura in massello di frassino tinto nero poro aperto. Disponibile anche in frassino naturale, tinto tabacco o tinto bianco poro aperto. Seduta con struttura interna in legno e derivati imbottita in poliuretano espanso indeformabile. Schienale in poliuretano strutturale annegato in schiuma poliuretanicamente flessibile. Rivestimento in tessuto o pelle nei colori del campionario.

! Non sfoderabile.

Per la realizzazione di elementi con rivestimento in pelle sono necessarie cuciture aggiuntive rispetto agli elementi con rivestimento in tessuto.

Il massello di frassino naturale presenta variazioni di colore che vanno dal biondo chiaro al rosa fino ad arrivare al bruno pallido, con eventuali sfumature di verde. Queste differenze sono da considerarsi caratteristiche di questa essenza.

Il legno massello è molto sensibile alla luce, il posizionamento vicino a sorgenti di luce naturale ne compromette la colorazione e la stabilità. Un'elevata variazione della temperatura e umidità dell'aria può provocare la comparsa di microfratture e leggere variazioni.

Chair with black open pore stained solid ash structure. Also available in natural ash, tobacco stained or white open pore stained ash. Seat with inside structure in wood and by-products padded in non-deformable polyurethane foam. Backrest made of structural polyurethane dipped in flexible polyurethane foam. Covered by fabric or leather as per samples.

! Not removable cover.

Additional stitching is required for elements with leather upholstery compared to elements with fabric upholstery.

Natural ash solid wood has colour variations ranging from light blonde to pale brown, with possible shades of green. These differences are to be considered characteristic of this essence.

Solid wood is very light-sensitive, placing it near natural light sources may compromise its colour and stability. Considerable differences in air temperature and humidity may cause microfractures and slight variations.



Cm
53 x 51 x 74,5

Inches
21" x 20¼" x 29½"

For technical drawing / p. 109

Pricelist 2023 / p. 46
Homescapes, embracing beauty / pp. 36, 53
Homescapes, intimate portraits / p. 98

STRUTTURA/STRUCTURE

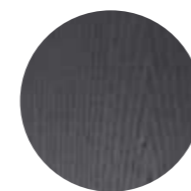

Frassino tinto
nero poro aperto
Black stained
open pore ash

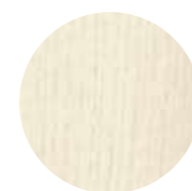

Frassino naturale
Natural ash

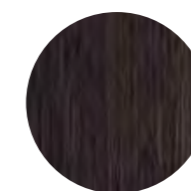

Frassino tinto tabacco
Tobacco stained ash



Frassino tinto
bianco poro aperto
White open pore
lacquered ash

RIVESTIMENTO/COVER



Tessuto/pelle nei colori del
campionario
Fabric/leather as per
samples.

Livrette

Federica Biasi / 2021

Poltroncina con struttura interna in legno imbottita con poliuretano espanso indeformabile a densità differenziate e fibra poliestere. Basamento in massello di frassino tinto nero poro aperto. Rivestimento in tessuto o pelle nei colori del campionario.

! **Non sfoderabile.**

Per la realizzazione di elementi con rivestimento in pelle sono necessarie cuciture aggiuntive rispetto gli elementi con rivestimento in tessuto.

Il legno massello è molto sensibile alla luce, il posizionamento vicino a sorgenti di luce naturale ne compromette la colorazione e la stabilità. Un'elevata variazione della temperatura e umidità dell'aria può provocare la comparsa di microfratture e leggere variazioni.

Armchair with inside structure in wood padded with non-deformable polyurethane foam in different density and polyester fibre. Black open pore stained solid ash base. Covered by fabric or leather as per samples.

! **Not removable cover.**

Additional stitching is required for elements with leather upholstery compared to elements with fabric upholstery.

Solid wood is very light-sensitive, placing it near natural light sources may compromise its colour and stability. Considerable differences in air temperature and humidity may cause microfractures and slight variations.



Cm
65 x 55 x 72

Inches
25¾" x 21¾" x 28½"

[For technical drawing / p.110](#)

[Pricelist 2023 / p. 47](#)
[Homescapes, intimate portraits / pp. 33, 74](#)

BASE/BASE

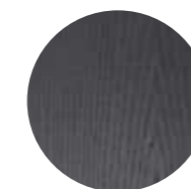

Frassino tinto nero poro aperto
Black stained open pore ash

RIVESTIMENTO/COVER



Tessuto/pelle nei colori del campionario
Fabric/leather as per samples.

▲ **LIVRETTE**
Rivestimento in velvet Brick 3701
Cover in velvet Brick 3701

Thea

Pinuccio Borgonovo / 2015

Sedia con struttura interna in legno e derivati, imbottita in poliuretano espanso indeformabile a densità differenziate e fibra poliestere. Rivestimento in tessuto o pelle nei colori del campionario. Gambe in rovere laccato nero poro aperto.

Chair with inside structure in wood and by-products padded in non-deformable foam polyurethane in different density and polyester fibre. Covered by fabric or leather as per samples. Black open pore lacquered oak legs.

! Non sfoderabile.

! Not removable cover.

Per la realizzazione di elementi con rivestimento in pelle sono necessarie cuciture aggiuntive rispetto gli elementi con rivestimento in tessuto.

Additional stitching is required for elements with leather upholstery compared to elements with fabric upholstery.



Cm
50 x 57 x 80

Inches
19¾" x 22½" x 31½"

[For technical drawing / p. 110](#)

[Pricelist 2023 / p. 49](#)
[Homescapes, sense of materials / p. 44](#)
[Homescapes, intimate portraits / p. 29](#)

RIVESTIMENTO/COVER



Tessuto/pelle nei colori del campionario
Fabric/leather as per samples.

STRUTTURA E GAMBE/ STRUCTURE AND LEGS

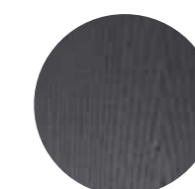

Rovere laccato
nero poro aperto
Black open pore
lacquered oak

▲ THEA
Gambe in rovere tinto nero poro aperto / Rivestimento in velvet Sage green 6381
Black open pore lacquered oak legs / Cover in velvet Sage green 6381



▲ **THEA QUEEN**
 Gambe in rovere tinto nero poro aperto / Rivestimento in velvet Mink 518
 Black open pore lacquered oak legs / Cover in velvet Mink 518

Thea Queen

Pinuccio Borgonovo / 2016

Poltroncina con struttura interna in legno e derivati imbottita in poliuretano espanso indeformabile a densità differenziate e fibra poliestere. Rivestimento in tessuto o pelle nei colori del campionario. Gambe in rovere laccato nero poro aperto. Disponibile versione "lounge".

! Non sfoderabile.

Per la realizzazione di elementi con rivestimento in pelle sono necessarie cuciture aggiuntive rispetto gli elementi con rivestimento in tessuto.

Armchair with inside structure in wood and by-products padded in non-deformable foam polyurethane in different density and polyester fibre. Covered by fabric or leather as per samples. Black open pore lacquered oak legs. Also available "lounge" version.

! Not removable cover.

Additional stitching is required for elements with leather upholstery compared to elements with fabric upholstery.



Cm
 63 x 63 x 80
 63 x 63 x 71 (lounge)

Inches
 25" x 25" x 31½"
 25" x 25" x 28" (lounge)

[For technical drawing / p.110](#)

[Pricelist 2023 / p. 50](#)
[Homescapes, sense of materials / p. 110](#)

RIVESTIMENTO/COVER



Tessuto/pelle nei colori del campionario
 Fabric/leather as per samples.

STRUTTURA E GAMBE/ STRUCTURE AND LEGS

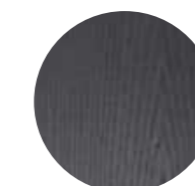

Rovere laccato
 nero poro aperto
 Black open pore
 lacquered oak

02

Sedute / Seating
TECHNICAL MODULE

GENERAL INDICATION

	CAT.A										CAT.B													CAT.C										CAT.D	CAT.L1	CAT.L2														
	Care	Chill	Cozy	Delight	Gape	Hope	Infinity	Joy	Sauvage	Velvet	Berlino	Daze	Delia	Glee	Glow	Harmony	Maze	Mingle	Path	Perky	Perseo	Sofi	Soul	Tokyo	Touch	Twist	Vision	Armônia	Bloom	Eden	Euphoria	Fluffy	Freedom	Futura	Utopia	Wonder	Aiko	Pleasure	Zest	Fard	Suede*	Leather*	Nabuk*							
0414	■	■	■	■	■	■	■	■	■	■	■	■	■	■	■	■	■	■	■	■	■	■	■	■	■	■	■	■	■	■	■	■	■	■	■	■	■	■	■	■	■	■	■	■	■	■	■			
0419	■	■	■	■	■	■	■	■	■	■	■	■	■	■	■	■	■	■	■	■	■	■	■	■	■	■	■	■	■	■	■	■	■	■	■	■	■	■	■	■	■	■	■	■	■	■	■			
Akiko	□	■	■	■	■	■	■	■	■	■	■	■	■	■	■	■	■	■	■	■	■	■	■	■	■	■	□	■	■	■	■	■	■	■	■	■	□	■	■	■	■	■	■	■	■	■	■			
Jackie	■	■	■	■	■	■	■	■	■	■	■	■	■	■	■	■	■	■	■	■	■	■	■	■	■	■	■	■	■	■	■	■	■	■	■	■	■	■	■	■	■	■	■	■	■	■	■			
Keyko	■	■	■	■	■	■	■	■	■	■	■	■	■	■	■	■	■	■	■	■	■	■	■	■	■	■	■	■	■	■	■	■	■	■	■	■	■	■	■	■	■	■	■	■	■	■	■	■		
Livrette	■	■	■	■	■	■	■	■	■	■	■	■	■	■	■	■	■	■	■	■	■	■	■	■	■	■	■	■	■	■	■	■	■	■	■	■	■	■	■	■	■	■	■	■	■	■	■	■		
Janette	■	■	■	■	■	■	■	■	■	■	■	■	■	■	■	■	■	■	■	■	■	■	■	■	■	■	■	■	■	■	■	■	■	■	■	■	■	■	■	■	■	■	■	■	■	■	■	■		
Thea	■	■	■	■	■	■	■	■	■	■	■	■	■	■	■	■	■	■	■	■	■	■	■	■	■	■	■	■	■	■	■	■	■	■	■	■	■	■	■	■	■	■	■	■	■	■	■	■	■	
Thea Queen	■	■	■	■	■	■	■	■	■	■	■	■	■	■	■	■	■	■	■	■	■	■	■	■	■	■	■	■	■	■	■	■	■	■	■	■	■	■	■	■	■	■	■	■	■	■	■	■	■	■

*cuciture per versione in pelle

*stitching for leather covers

! Gallotti&Radice declina ogni responsabilità rispetto le prestazioni tecniche ed estetiche dei prodotti realizzati con tessuti/pelli non consigliate.

! Gallotti & Radice declines all responsibility for the technical and aesthetic performances of products made with non-recommended fabrics / leathers.

Gallotti&Radice declina ogni responsabilità rispetto alle prestazioni tecniche ed estetiche dei prodotti rivestiti con C.O.L. e C.O.M.

Gallotti & Radice declines all responsibility for technical and aesthetic performance of products covered with C.O.L. and C.O.M.

Per informazioni di dettaglio relative alla composizione, proprietà e lavaggio/ manutenzione dei rivestimenti si rinvia al "Volume 4 | Materiali".

For detailed information on the composition, properties and maintenance of the upholstery, please refer to the "Volume 4 | Materials".

È possibile rivestire tutti i prodotti della collezione Gallotti&Radice con con tessuto/ pelle cliente, previa approvazione di un campione. Gallotti&Radice non è responsabile per quanto riguarda il risultato formale, la durata del tessuto e la costanza dei colori (vedi: "Volume 4 | Materiali").

Furniture may be upholstered with customers' own fabrics after approval of a sample. Gallotti&Radice is not responsible for the aesthetic result, durability of the fabric and the uniformity of the colours (see: Volume 4 | Materials).

L'approvazione del tessuto fornito dal Cliente da parte di Gallotti&Radice si limita solamente alla realizzazione della tappezzeria.

The approval by Gallotti&Radice of the C.O.L. and C.O.M is limited only to the upholstery. Gallotti&Radice therefore declines all responsibility for resistance to use, any resistance to fire or other technical characteristics of the fabrics supplied by the customer.

Gallotti&Radice declina pertanto ogni responsabilità in merito alla resistenza all'uso, alla eventuale resistenza al fuoco o ad altre caratteristiche tecniche dei tessuti forniti dal Cliente.

Gallotti & Radice is not responsible for the materials sent by the customer, for any defects and technical deficiencies of the same, for possible defective reactions to the upholstered product as well as for the instructions regarding maintenance and washing.

Gallotti&Radice non è responsabile dei materiali inviati dal cliente, di eventuali difetti e carenze tecniche degli stessi, delle possibili reazioni difettose a prodotto tappezzato nonché delle istruzioni riguardanti manutenzione e lavaggio.

0414 | Studio G&R, 2014

Product information / p. 86

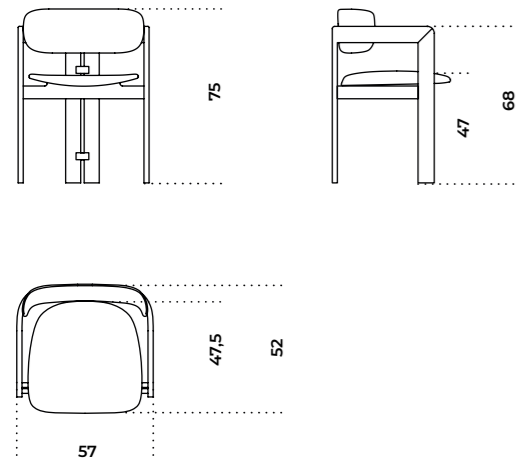

Jackie | Stefano Bigi, 2014

Product information / p. 92

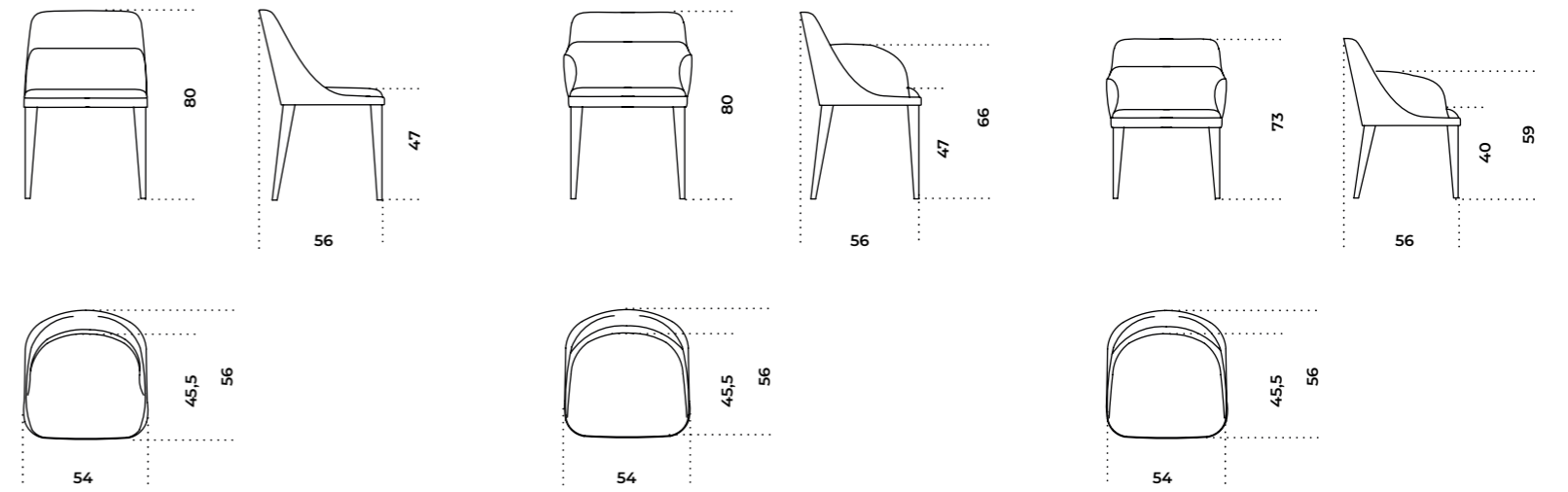

Sedia
Chair

Poltroncina
Armchair

Poltroncina Lounge
Armchair Lounge

0419 | Studio G&R, 2019

Product information / p. 88

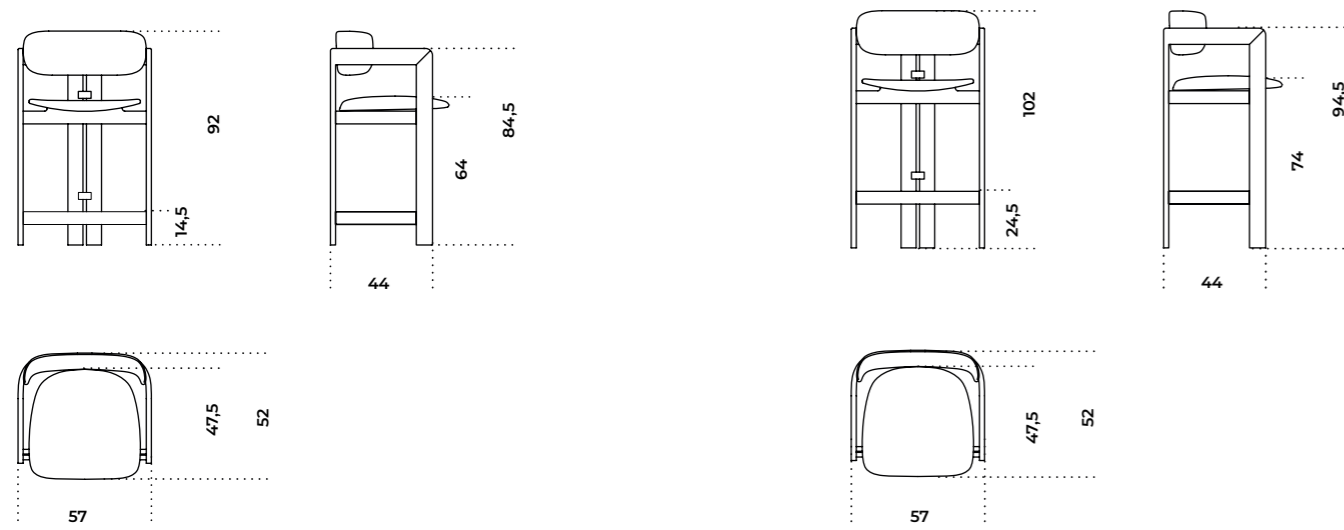

Janette | Federica Biasi, 2023

Product information / p. 94

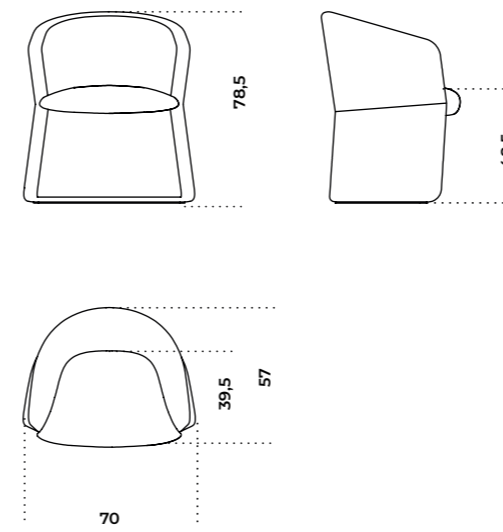

Akiko | Oscar e Gabriele Buratti, 2021

Product information / p. 90

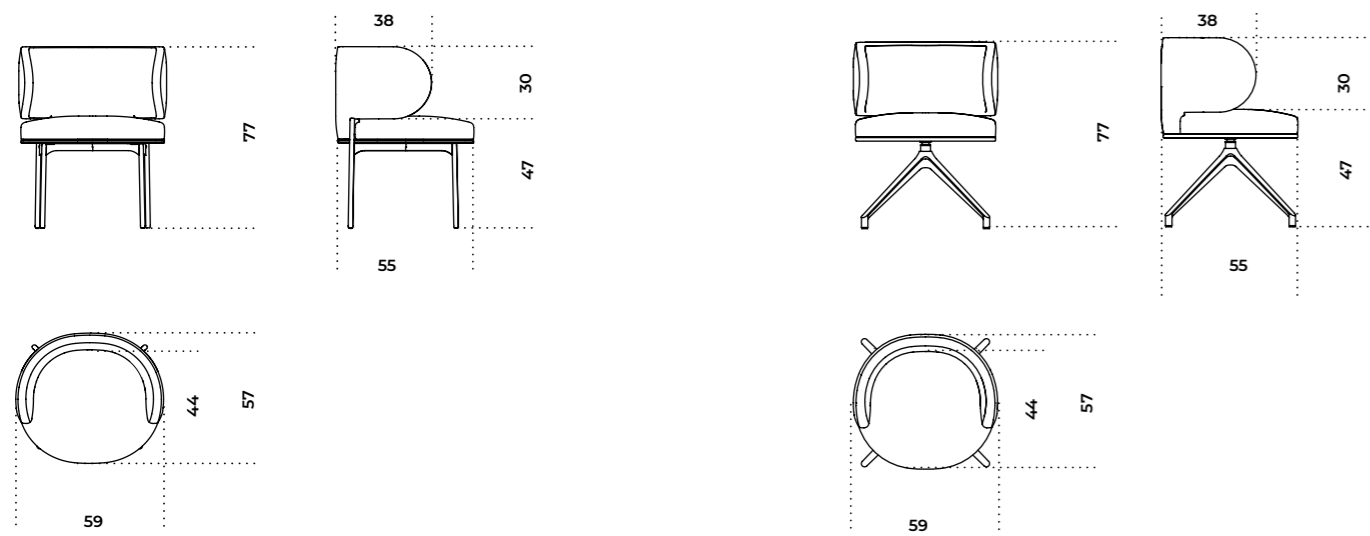

Versione girevole
Swivel version

Keyko | Pinuccio Borgonovo, 2017

Product information / p. 96

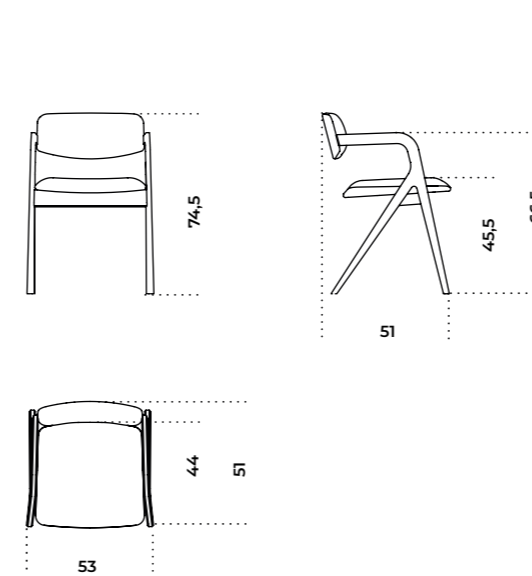

Livrette | Federica Biasi, 2021

[Product information / p.98](#)

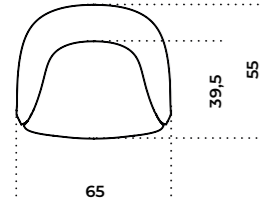
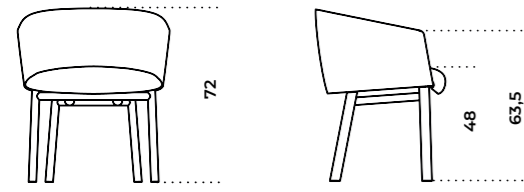

Thea | Pinuccio Borgonovo, 2015

[Product information / p.100](#)

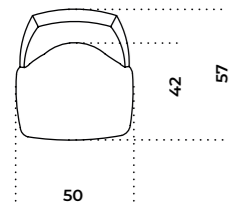
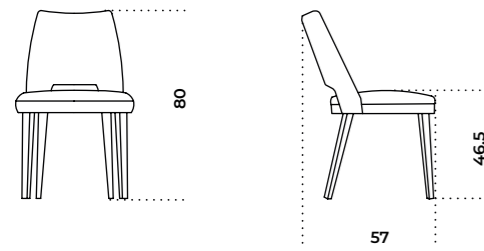

Thea Queen | Pinuccio Borgonovo, 2016

[Product information / p.102](#)

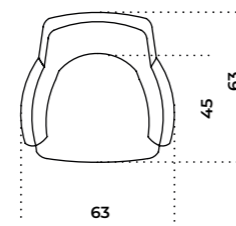
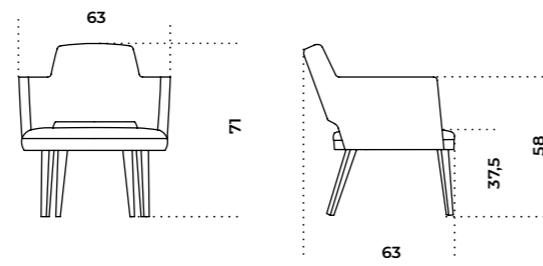
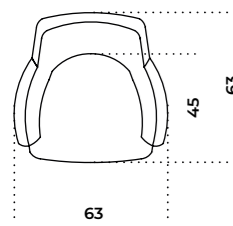
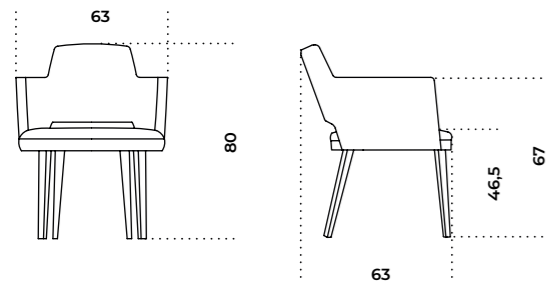

Lounge

03 Carrelli /
Trolleys

114 Mister

116 Riki

118 Informazioni tecniche/
Technical informations

Mister

Andreas Weber / 1998

Carrello in cristallo trasparente 10mm. Su richiesta cristallo retroverniciato nei colori del campionario nella versione brillante o satinata. Struttura in acciaio inox lucido o satinato. Maniglie in rovere sbiancato, tinto wengé, tinto tabacco o rovere laccato nero poro aperto. Disponibili versioni "total color" con struttura bianco, grigio o nero opaco con piani in cristallo retroverniciato satinato nello stesso colore della struttura.

Trolley in 10mm transparent glass. Painted glass as per samples in the bright or satin version on request. Bright or satin stainless steel metal parts. Handles in whitened oak, wengé stained, tobacco stained or black open pore lacquered oak. Available versions "total color" with lacquered structure opaque white, opaque grey and opaque black with satin painted glass tops in the same colour of the structure.



Piani in cristallo trasparente / Struttura in acciaio inox lucido / Maniglie in rovere tinto nero
Transparent glass tops / Bright stainless steel structure / Black stained oak handles

For technical drawing / p.120

Pricelist 2023 / p.194
Homescapes, intimate portraits / pp.41,45

Cm
84 x 48 x 82

Inches
33¼" x 19" x 32½"

PIANI/TOPS



Cristallo trasparente
Transparent glass

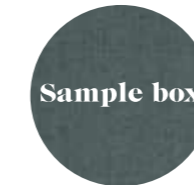

Sample box

Cristallo brillante/satinato
nei colori del campionario
Glass bright/satin version
as per samples

STRUTTURA/STRUCTURE



Acciaio inox lucido/satinato
Bright/Satin stainless steel

MANIGLIE/HANDLES

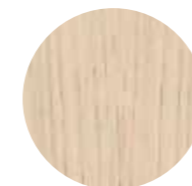

Rovere sbiancato
Whitened oak



Rovere tinto wengé
Wengé stained oak

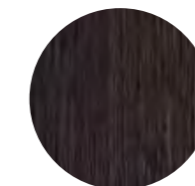

Rovere tinto tabacco
Tobacco stained oak

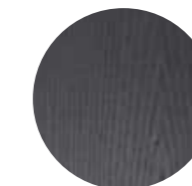

Rovere laccato nero
poro aperto
Black open pore
lacquered oak

STRUTTURA E MANIGLIE/STRUCTURE AND HANDLES "TOTAL COLOR" VERSION

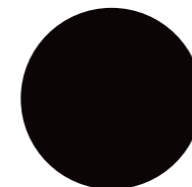

"Total color" nero opaco
"Total color" opaque black



"Total color" grigio
umbro opaco
"Total color" opaque
dark grey



"Total color" bianco opaco
"Total color" opaque white

PIANI/TOPS

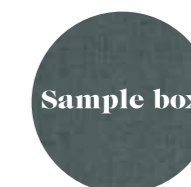

Sample box

Cristallo retroverniciato satinato
nello stesso colore della struttura
Satin painted glass tops in the same
colour of the structure.



▲ RIKI
Piani in cristallo trasparente / Struttura in ottone cromato
Transparent glass top / Chromed brass frame

Riki

Pierangelo Gallotti / 1971

Carrello in cristallo trasparente o extralight 8mm. Su richiesta cristallo retroverniciato nei colori del campionario nella versione brillante o satinata. Struttura in ottone cromato. A richiesta ottone lucido o satinato.

Trolley in 8mm transparent or extralight glass. Painted glass as per samples in the bright or satin version on request. Chromed brass frame. Bright or satin brass frame on request.



	Cm	Inches
T52/1	82 x 38 x 69	32½" x 15" x 27¼"
T52/2	96 x 46 x 69	38" x 18¼" x 27¼"
T53	Ø 60 x 69	Ø 23¾" x 27¼"

[For technical drawing / p. 120](#)

[Pricelist 2023 / p. 196](#)
[Homescapes, embracing beauty / p. 16](#)
[Homescapes, intimate portraits / p. 31](#)

PIANO/TOP



Cristallo trasparente
Transparent glass



Cristallo extralight
Extralight glass

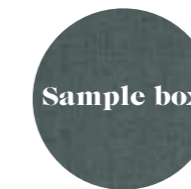

Sample box

Cristallo brillante/satinato
nei colori del campionario
Glass bright/satin version as
per samples

STRUTTURA/STRUCTURE



Ottone cromato
Chrome

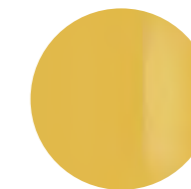

Ottone lucido
Bright brass



Ottone satinato
Satin brass

03

Carrelli / Trolleys
TECHNICAL MODULE

Mister | Andreas Weber, 1998

[Product information / p. 114](#)

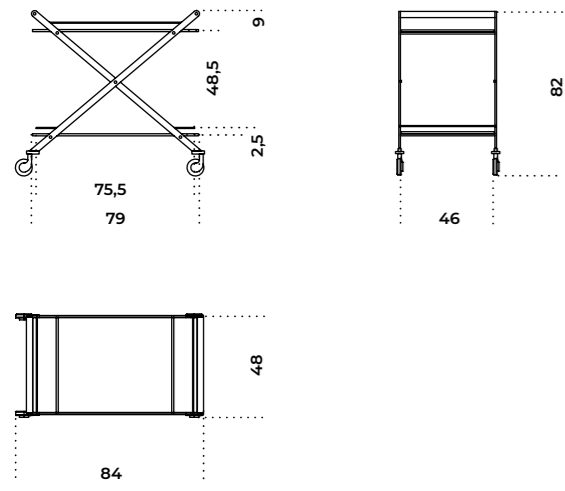

Riki | Pierangelo Gallotti, 1971

[Product information / p. 116](#)

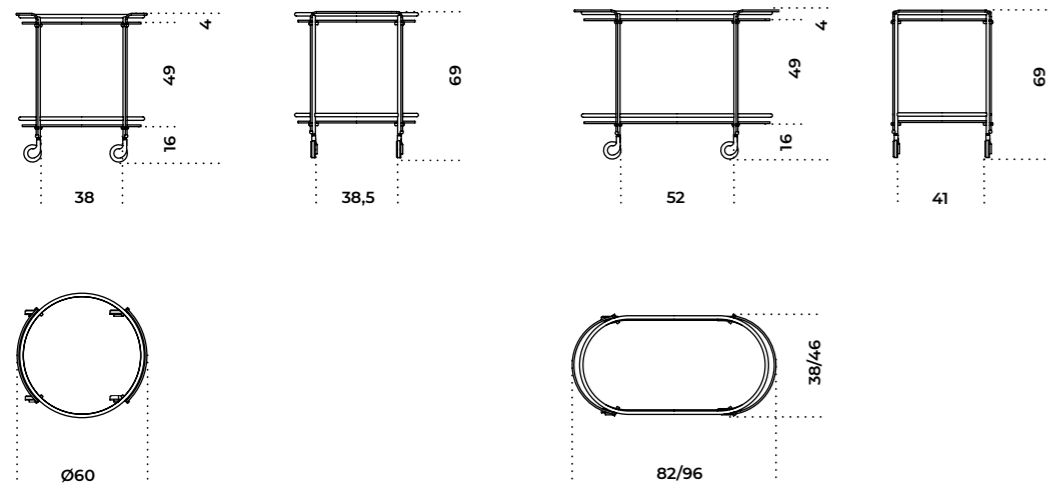

T53

T52/1
T52/2

04 Panche e Pouf /

Benches and Pouffe

124 [Audrey Pouf](#)

126 [Cloud Pouf](#)

128 [Lilas Bench](#)

130 [Lou](#)

132 [Oly](#)

134 [Stami Bench](#)

136 [Stami DayBed](#)

138 [Stami Pouf](#)

140 [Twelve DayBed](#)

142 [Informazioni tecniche/](#)

[Technical informations](#)

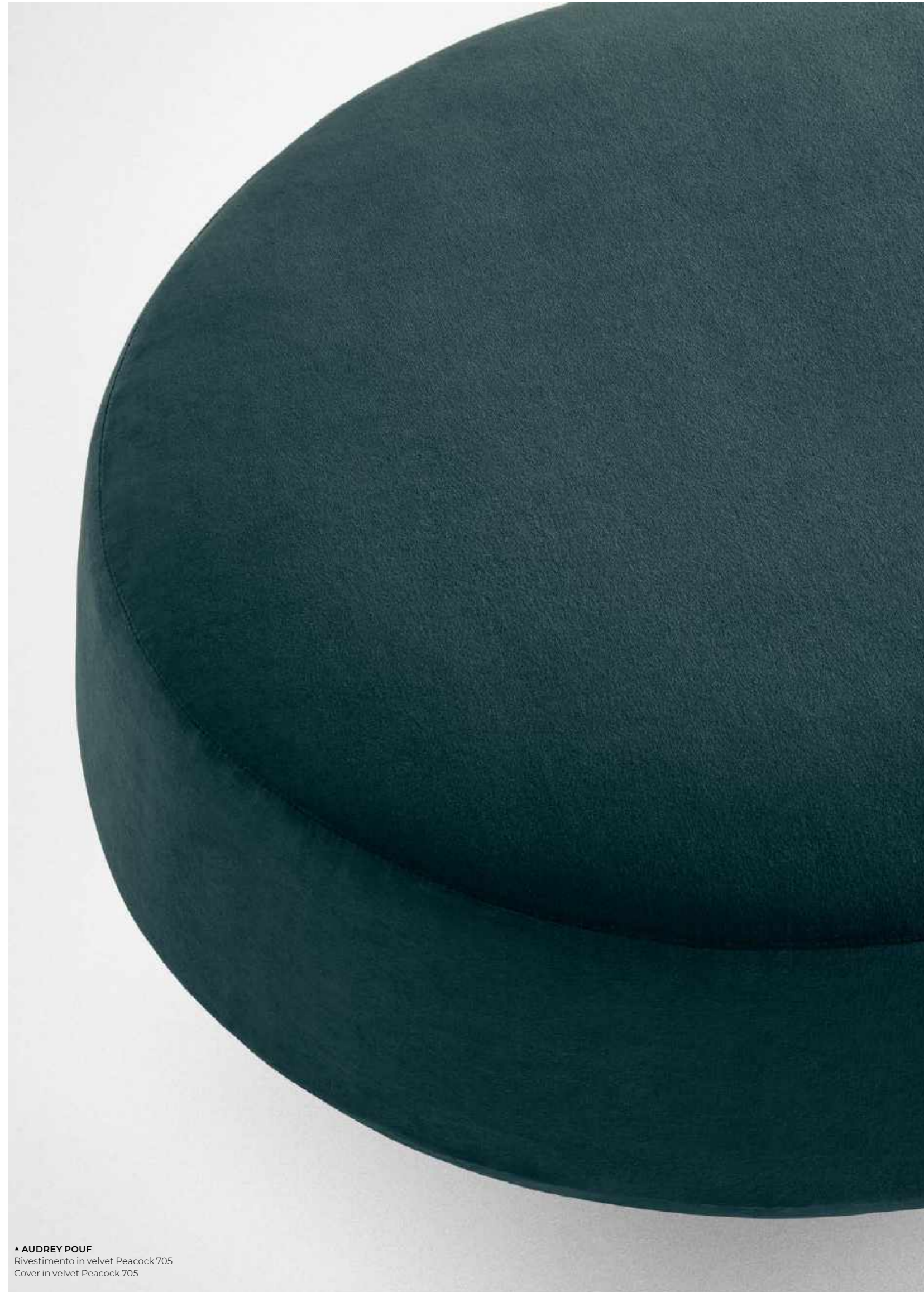

• **AUDREY POUF**
Rivestimento in velvet Peacock 705
Cover in velvet Peacock 705

Audrey Pouf

Massimo Castagna / 2019

Pouf in poliuretano espanso indeformabile a densità differenziate e fibra poliestere con struttura interna legno. Basamento in MDF in massa nero. Disponibile con rivestimento in tessuto o pelle nei colori del campionario.

Pouffe in non-deformable foam polyurethane in different density and polyester fibre with wooden inside structure. Black coloured MDF base. Available covered by fabric or leather as per sample.

! Su richiesta rivestimento sfoderabile escluso in Cat. L1, L2 e pelle cliente/C.O.L.

! On demand removable cover excluding in Cat. L1, L2 and client supplied leather.

Per la realizzazione di elementi con rivestimento in pelle sono necessarie cuciture aggiuntive rispetto gli elementi con rivestimento in tessuto.

Additional stitching is required for elements with leather upholstery compared to elements with fabric upholstery.



Cm
100 x 80 x 38
118 x 95 x 38

Inches
39½" x 31½" x 15"
46½" x 37½" x 15"

[For technical drawing / p.146](#)

[Pricelist 2023 / p.54](#)
[Homescapes, sense of materials / pp.74,81](#)
[Homescapes, gentle attitude / pp.45,48,58,61](#)

RIVESTIMENTO/COVER



Tessuto/pelle nei colori del campionario
Fabric/leather as per samples.

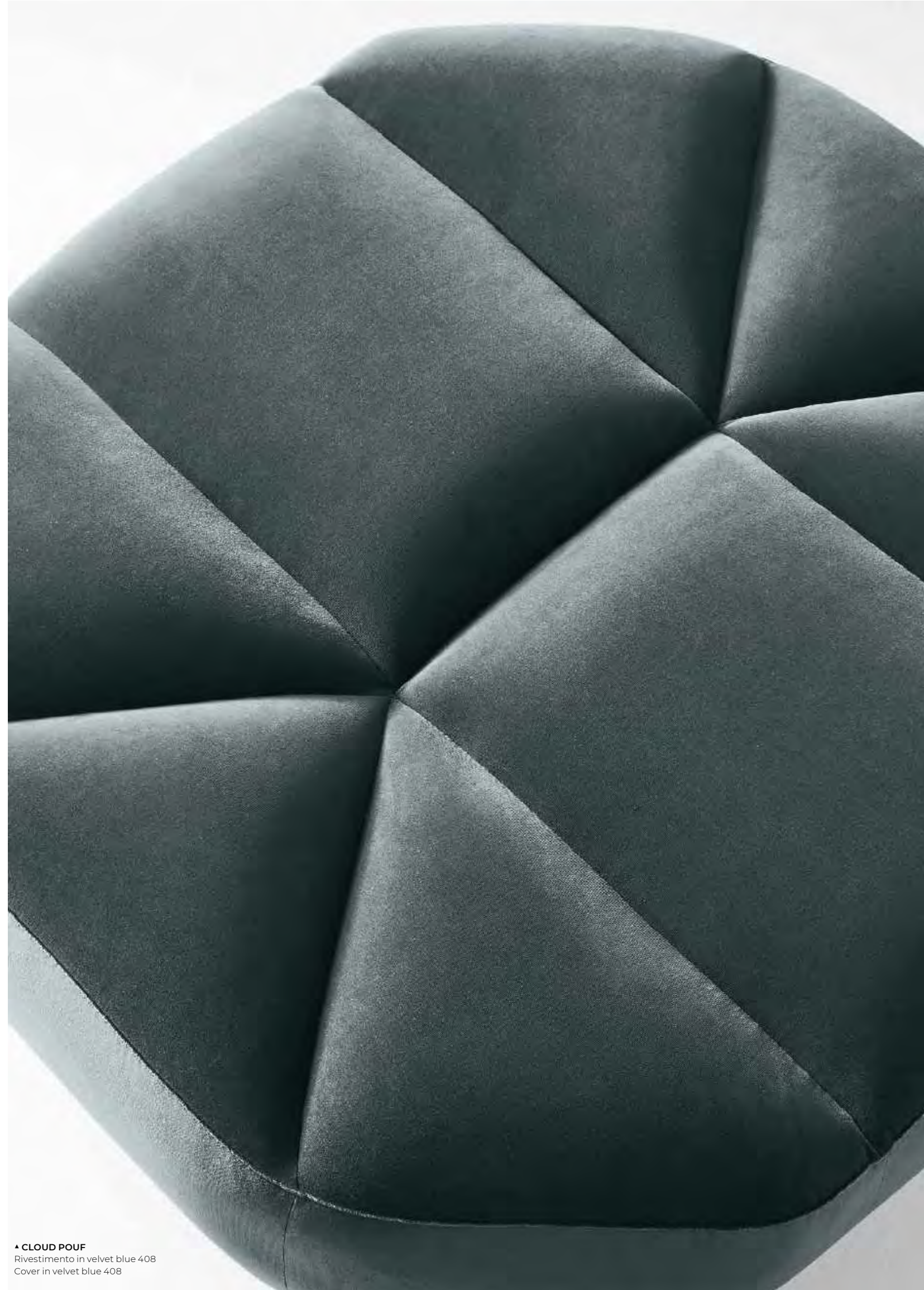

▲ **CLOUD POUF**
 Rivestimento in velvet blue 408
 Cover in velvet blue 408

Cloud Pouf

Massimo Castagna / 2017

Pouf in poliuretano espanso indeformabile a densità differenziate e fibra poliestere con struttura interna in legno. Piedi in legno laccato nero. Disponibile con rivestimento in tessuto o pelle nei colori del campionario.

Pouffe in non-deformable foam polyurethane in different density and polyester fibre with wooden inside structure. Black lacquered wooden feet. Available covered by fabric or leather as per sample.

! Non sfoderabile.

! Not removable cover.

Per la realizzazione di elementi con rivestimento in pelle sono necessarie cuciture aggiuntive rispetto gli elementi con rivestimento in tessuto.

Additional stitching is required for elements with leather upholstery compared to elements with fabric upholstery.



Cm

88 x 82 x 42
 110 x 106 x 42
 113 x 67 x 42
 190 x 67 x 42

Inches

34 $\frac{3}{4}$ " x 32 $\frac{1}{2}$ " x 16 $\frac{3}{4}$ "
 43 $\frac{1}{2}$ " x 41 $\frac{3}{4}$ " x 16 $\frac{3}{4}$ "
 44 $\frac{1}{2}$ " x 26 $\frac{1}{2}$ " x 16 $\frac{3}{4}$ "
 43 $\frac{1}{2}$ " x 26 $\frac{1}{2}$ " x 16 $\frac{3}{4}$ "

[For technical drawing / p.146](#)

[Pricelist 2023 / p.55](#)
[Homescapes, intimate portraits / p.107](#)
[Homescapes, gentle attitude / pp.24, 25, 72, 73](#)

RIVESTIMENTO/COVER



Tessuto/pelle nei colori del campionario
 Fabric/leather as per samples.

Lilas Bench

Dainelli Studio / 2022

Panca in poliuretano espanso indeformabile a densità differenziate e fibra poliestere. Piastra di base in metallo laccato nero. Disponibile con rivestimento sfoderabile in tessuto o pelle nei colori del campionario. Tavolini in metallo laccato color fango disponibili su richiesta.

Bench in non-deformable polyurethane foam in different density and polyester fibre. Black lacquered metal base plate. Available with removable cover in fabric or leather as per samples. Fango lacquered metal side table on request.

! **Rivestimento sfoderabile.**

Per la realizzazione di elementi con rivestimento in pelle sono necessarie cuciture aggiuntive rispetto gli elementi con rivestimento in tessuto.

! **Removable cover.**

Additional stitching is required for elements with leather upholstery compared to elements with fabric upholstery.



Cm
160 x 50 x 40

Inches
63" x 19¾" x 15¾"

Tavolino S
50 x 25 x 22

Side table S
19¾" x 10" x 8¾"

Tavolino M
50 x 35 x 22

Side table M
19¾" x 14" x 8¾"

[For technical drawing / p.146](#)

[Pricelist 2023 / p.57](#)
[Homescapes, intimate portraits / p.107](#)
[Homescapes, gentle attitude / pp.52,55](#)

RIVESTIMENTO/COVER



Tessuto/pelle nei colori del campionario
Fabric/leather as per samples.

▲ **LILAS BENCH**
Rivestimento in Velvet peacock 705
Cover in Velvet peacock 705



• LOU
Rivestimento in velvet Mink 518
Cover in velvet Mink 518

Lou

Studio G&R / 2015

Pouf con struttura interna in legno e derivati imbottito in poliuretano espanso indeformabile a densità differenziate e fibra poliestere. Parti metalliche in ottone satinato o laccato nero opaco. Rivestimento in tessuto o pelle nei colori del campionario. Disponibile versione "loungue".

! Non sfoderabile.

Per la realizzazione di elementi con rivestimento in pelle sono necessarie cuciture aggiuntive rispetto gli elementi con rivestimento in tessuto.

Pouffe with inside structure in wood and by-products padded in non-deformable foam polyurethane in different density and polyester fibre. Metal parts in satin brass or matt black lacquered brass. Covered by fabric or leather as per samples. Also available "loungue" version.

! Not removable cover.

Additional stitching is required for elements with leather upholstery compared to elements with fabric upholstery.



	Cm	Inches
S	Ø 38 x 46	Ø 15" x 18¼"
	Ø 38 x 41 (loungue)	Ø 15" x 16¼"
L	58 x 36 x 46	23" x 14¼" x 18¼"
	58 x 36 x 41 (loungue)	23" x 14¼" x 16¼" (loungue)

For technical drawing / p.147

Pricelist 2023 / p. 58
Homescapes, sense of materials / pp. 92, 108
Homescapes, embracing beauty / p. 43
Homescapes, intimate portraits / p. 50
Homescapes, gentle attitude / pp. 15, 52, 53, 82, 83, 98, 99, 101

RIVESTIMENTO/COVER



Tessuto/pelle nei colori del campionario
Fabric/leather as per samples.

PARTI METALLICHE/ METAL PARTS



Ottone satinato
Satin brass

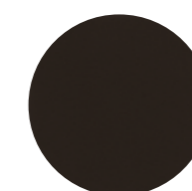

Ottone laccato nero opaco
Matt black lacquered brass



▲ OLY

Panca struttura in metallo laccato nero antracite / Rivestimento in Aiko Anthracite 002 / Cuscino a rullo rivestito in nabuk Rose powder 2104
 Bench anthracite grey lacquered metal structure / Cover in Aiko Anthracite 002 / Rollcushion covered by nabuk Rose powder 2104

Oly

Massimo Castagna / 2019

Panca e pouf con struttura in metallo laccato grigio antracite. Cuscino di seduta in poliuretano espanso indeformabile a densità differenziate e fibra poliestere e cuscino schienale a rullo rivestiti in tessuto o pelle nei colori del campionario. Cuscino decorativo in fibra poliestere su richiesta.

! **Rivestimento sfoderabile.**

Per la realizzazione di elementi con rivestimento in pelle sono necessarie cuciture aggiuntive rispetto gli elementi con rivestimento in tessuto.

Il legno massello è molto sensibile alla luce, il posizionamento vicino a sorgenti di luce naturale ne compromette la colorazione e la stabilità. Un'elevata variazione della temperatura e umidità dell'aria può provocare la comparsa di microfratture e leggere variazioni.

Bench and pouffe with anthracite grey lacquered metal structure. Seat cushion in non deformable foam polyurethane in different density and polyester fibre and back rollcushion covered by fabric or leather as per samples. Decorative polyester fibre cushions, on request.

! **Removable cover.**

Additional stitching is required for elements with leather upholstery compared to elements with fabric upholstery.

Solid wood is very light-sensitive, placing it near natural light sources may compromise its colour and stability. Considerable differences in air temperature and humidity may cause microfractures and slight variations.



Cm
Panca
 97 x 78 x 62
Pouf
 78 x 52 x 43

Cuscino decorativo
 40 x 40

Inches
Bench
 38¼" x 30¾" x 24½"
Pouffe
 30¾" x 20½" x 17"

Decorative cushion
 15¾" x 15¾"

[For technical drawing / p. 147](#)

[Pricelist 2023 / p. 60](#)
[Homescapes, sense of materials / p. 102](#)
[Homescapes, embracing beauty / p. 105](#)

STRUTTURA/STRUCTURE



Metallo laccato
 grigio antracite
 Anthracite grey
 lacquered metal

RIVESTIMENTO/COVER



Tessuto/pelle nei colori
 del campionario
 Fabric/leather as per
 samples.

Stami Bench

Studiopepe / 2022

Panca con base in frassino curvato tinto nero poro aperto e dettagli in ottone lucido. Cuscino in poliuretano espanso rivestito in tessuto o pelle nei colori del campionario. Rivestimento sfoderabile.

Bench with curved black open pore stained ash base and bright brass details. Cushion in polyurethane foam covered by fabric or leather as per samples. Removable cover.

! Rivestimento sfoderabile.

Per la realizzazione di elementi con rivestimento in pelle sono necessarie cuciture aggiuntive rispetto gli elementi con rivestimento in tessuto.

! Removable cover.

Additional stitching is required for elements with leather upholstery compared to elements with fabric upholstery.



Cm
140 x 45 x 45
160 x 45 x 45

Inches
55 1/4" x 17 3/4" x 17 3/4"
63" x 17 3/4" x 17 3/4"

[For technical drawing / p.147](#)

[Pricelist 2023 / p. 61](#)
[Homescapes, gentle attitude / pp. 21, 22, 24, 27, 37, 39](#)

BASE/BASE

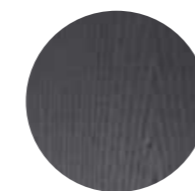

Frassino curvato tinto nero poro aperto
Curved black open pore stained ash

DETTAGLI/DETAILS

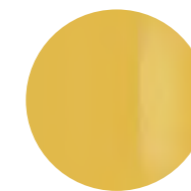

Ottone lucido
Bright brass

RIVESTIMENTO/COVER



Tessuto/pelle nei colori del campionario
Fabric as per samples.

▲ STAMI BENCH

Struttura in frassino curvato tinto nero poro aperto /
Dettagli in ottone lucido / Rivestimento in Delia milk 002
Curved black open pore stained ash base /
Bright brass details / Cover in Delia milk 002



▲ STAMI BENCH
Struttura in frassino curvato tinto nero poro aperto / Dettagli in ottone lucido / Rivestimento in Hope silver 106
Curved black open pore stained ash base / Bright brass details / Cover in Hope silver 106

Stami DayBed

Studiopepe / 2022

Day bed con base in frassino curvato tinto nero poro aperto e dettagli in ottone lucido. Cuscino in poliuretano espanso rivestito in tessuto o pelle nei colori del campionario. Il prodotto include un poggiatesta cilindrico zavorrato. Rivestimento sfoderabile.

! Rivestimento sfoderabile.

Per la realizzazione di elementi con rivestimento in pelle sono necessarie cuciture aggiuntive rispetto gli elementi con rivestimento in tessuto.

Day bed with curved black open pore stained ash base and bright brass details. Cushion in polyurethane foam covered by fabric or leather as per samples. Ballasted cylindrical headrest included. Removable cover.

! Removable cover.

Additional stitching is required for elements with leather upholstery compared to elements with fabric upholstery.



Cm
190 x 80 x 45

Inches
75" x 31½" x 17¾"

[For technical drawing / p. 148](#)

[Pricelist 2023 / p. 62](#)
[Homescapes, gentle attitude / pp. 50, 51, 92, 93](#)

BASE/BASE

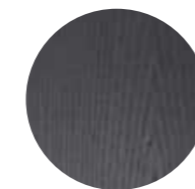

Frassino curvato tinto
nero poro aperto
Curved black open pore
stained ash

DETTAGLI/DETAILS

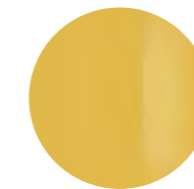

Ottone lucido
Bright brass

RIVESTIMENTO/COVER



Tessuto/pelle nei colori del
campionario
Fabric as per samples.

Stami Pouf

Studiopepe / 2022

Pouf con struttura interna in legno e derivati imbottito in poliuretano espanso indeformabile a densità differenziate e fibra poliestere. Zoccolo in frassino tinto nero poro aperto. Rivestimento in tessuto o pelle nei colori del campionario.

Pouffe with inside structure in wood and by-products padded in non-deformable foam polyurethane in different density and polyester fibre. Black open pore stained solid ash base. Covered by fabric or leather as per samples.

! Non sfoderabile.

Per la realizzazione di elementi con rivestimento in pelle sono necessarie cuciture aggiuntive rispetto gli elementi con rivestimento in tessuto.

! Not removable cover.

Additional stitching is required for elements with leather upholstery compared to elements with fabric upholstery.



Cm
Ø 38 x 44

Inches
Ø 15" x 18½"

[For technical drawing / p.148](#)

[Pricelist 2023 / p.63](#)
[Homescapes, gentle attitude / pp.45,54,57](#)

RIVESTIMENTO/COVER



Tessuto/pelle nei colori del campionario
Fabric/leather as per samples.

BASE/BASE



Frassino tinto nero poro aperto
Black stained open pore ash

▲ STAMI POUF
Rivestimento in fard Loden green 2357
Cover in fard Loden green 2357



▲ **TWELVE-DAY BED**
Struttura in ottone brunito a mano / Rivestimento in leather Black 001
Hand burnished brass structure / Cover in leather Black 001

Twelve DayBed

Massimo Castagna / 2016

Day bed con struttura in ottone brunito a mano con materasso in poliuretano espanso rivestito in tessuto o pelle nei colori del campionario. Poggiatesta disponibile per la versione da 200 cm.

! Rivestimento sfoderabile.

Per la realizzazione di elementi con rivestimento in pelle sono necessarie cuciture aggiuntive rispetto gli elementi con rivestimento in tessuto.

NOTE TECNICHE SUI MATERIALI

OTTONE BRUNITO A MANO | L'ottone brunito a mano è ottenuto da un processo di ossidazione naturale eseguito manualmente. Il risultato di questa lavorazione è un prodotto che può presentare macchie e variazioni di colore che non sono da considerarsi imperfezioni ma caratteristiche che conferiscono ad ogni pezzo una particolare unicità, rendendolo esclusivo.

Day bed with hand burnished brass structure with mattress in foam polyurethane covered by fabric or leather as per sample. Headrest available only for cm 200 version.

! Removable cover.

Additional stitching is required for elements with leather upholstery compared to elements with fabric upholstery.

TECHNICAL INFORMATION ON THE MATERIALS

HAND BURNISHED BRASS | The hand burnished brass is the consequence of hand-made process of natural oxidation. The result of this processing is a product that may show marks and colour variations. These differences are inevitable and should not be considered imperfections but distinctive features due to this craftmade processing, each product is unique and exclusive.



Cm
160 x 50 x 35
200 x 80 x 40

Inches
63" x 19¾" x 14"
78¾" x 31½" x 15¾"

[For technical drawing / p. 148](#)

[Pricelist 2023 / p. 64](#)
[Homescapes, embracing beauty / pp. 54, 106](#)

STRUTTURA/STRUCTURE



Ottone brunito a mano
Hand burnished brass

RIVESTIMENTO/COVER



Tessuto/pelle nei colori del campionario
Fabric as per samples.

04

Panche e Pouf / Benches and Pouffe TECHNICAL MODULE

GENERAL INDICATION

■ tessuto/pelle consigliato
suggested fabric/leather
tissu/cuir conseillé
empfohlener Stoff/Leder

□ tessuto/pelle non utilizzabile
non-usable fabric/leather
tissu/cuir non utilisable
nicht verwendbarer Stoff/Leder

	CAT.A											CAT.B											CAT.C											CAT.D		CAT.L1	CAT.L2											
	Care	Chill	Cozy	Delight	Gape	Hope	Infinity	Joy	Sauvage	Velvet	Berlino	Daze	Deja	Glee	Glow	Harmony	Maze	Mingle	Path	Perky	Perseo	Sofi	Soul	Tokyo	Touch	Twist	Vision	Armònia	Bloom	Eden	Euphoria	Fluffy	Freedom	Futura	Utopia	Wonder	Aiko	Pleasure	Zest	Fard	Suede*	Leather*	Nabuk*					
Audrey Pouf	■	■	■	■	■	■	■	■	■	■	■	■	■	■	■	■	■	■	■	■	■	■	■	■	■	■	■	■	■	■	■	■	■	■	■	■	■	■	■	■	■	■	■	■	■	■		
Cloud Pouf	■	■	■	■	■	■	■	■	■	■	■	■	■	■	■	■	■	■	■	■	■	■	■	■	■	■	■	■	■	■	■	■	■	■	■	■	■	■	■	■	■	■	■	■	■	■		
Lilas Bench	■	■	■	■	■	■	■	■	■	■	■	■	■	■	■	■	■	■	■	■	■	■	■	■	■	■	■	■	■	■	■	■	■	■	■	■	■	■	■	■	■	■	■	■	■	■		
Lou	■	■	■	■	■	■	■	■	■	■	■	■	■	■	■	■	■	■	■	■	■	■	■	■	■	■	■	■	■	■	■	■	■	■	■	■	■	■	■	■	■	■	■	■	■	■		
Oly	■	■	■	■	■	■	■	■	■	■	■	■	■	■	■	■	■	■	■	■	■	■	■	■	■	■	■	■	■	■	■	■	■	■	■	■	■	■	■	■	■	■	■	■	■	■		
Stami Bench	■	■	■	■	■	■	■	■	■	■	■	■	■	■	■	■	■	■	■	■	■	■	■	■	■	■	■	■	■	■	■	■	■	■	■	■	■	■	■	■	■	■	■	■	■	■	■	
Stami Daybed	■	■	■	■	■	■	■	■	■	■	■	■	■	■	■	■	■	■	■	■	■	■	■	■	■	■	■	■	■	■	■	■	■	■	■	■	■	■	■	■	■	■	■	■	■	■	■	
Stami Pouf	■	■	■	■	■	■	■	■	■	■	■	■	■	■	■	■	■	■	■	■	■	■	■	■	■	■	■	■	■	■	■	■	■	■	■	■	■	■	■	■	■	■	■	■	■	■	■	
Twelve Daybed	■	■	■	■	■	■	■	■	■	■	■	■	■	■	■	■	■	■	■	■	■	■	■	■	■	■	■	■	■	■	■	■	■	■	■	■	■	■	■	■	■	■	■	■	■	■	■	■
cushions	■	■	■	■	■	■	■	■	■	■	■	■	■	■	■	■	■	■	■	■	■	■	■	■	■	■	■	■	■	■	■	■	■	■	■	■	■	■	■	■	■	■	■	■	■	■	■	■

*cuciture per versione in pelle

! Gallotti&Radice declina ogni responsabilità rispetto le prestazioni tecniche ed estetiche dei prodotti realizzati con tessuti/pelli non consigliate.

Gallotti&Radice declina ogni responsabilità rispetto alle prestazioni tecniche ed estetiche dei prodotti rivestiti con C.O.L. e C.O.M.

Per informazioni di dettaglio relative alla composizione, proprietà e lavaggio/manutenzione dei rivestimenti si rinvia al "Volume 4 | Materiali".

È possibile rivestire tutti i prodotti della collezione Gallotti&Radice con tessuto/pelle cliente, previa approvazione di un campione. Gallotti&Radice non è responsabile per quanto riguarda il risultato formale, la durata del tessuto e la costanza dei colori (vedi: "Volume 4 | Materiali").

L'approvazione del tessuto fornito dal Cliente da parte di Gallotti&Radice si limita solamente alla realizzazione della tappezzeria.

Gallotti&Radice declina pertanto ogni responsabilità in merito alla resistenza all'uso, alla eventuale resistenza al fuoco o ad altre caratteristiche tecniche dei tessuti forniti dal Cliente.

Gallotti&Radice non è responsabile dei materiali inviati dal cliente, di eventuali difetti e carenze tecniche degli stessi, delle possibili reazioni diftose a prodotto tappezzato nonché delle istruzioni riguardanti manutenzione e lavaggio.

*stitching for leather covers

! Gallotti & Radice declines all responsibility for the technical and aesthetical performances of products made with non-recommended fabrics / leathers.

Gallotti & Radice declines all responsibility for technical and aesthetic performance of products covered with C.O.L. and C.O.M.

For detailed information on the composition, properties and maintenance of the upholstery, please refer to the "Volume 4 | Materials".

Furniture may be upholstered with customers' own fabrics after approval of a sample. Gallotti&Radice is not responsible for the aesthetic result, durability of the fabric and the uniformity of the colours (see: Volume 4 | Materials).

The approval by Gallotti&Radice of the C.O.L. and C.O.M. is limited only to the upholstery. Gallotti&Radice therefore declines all responsibility for resistance to use, any resistance to fire or other technical characteristics of the fabrics supplied by the customer.

Gallotti & Radice is not responsible for the materials sent by the customer, for any defects and technical deficiencies of the same, for possible defective reactions to the upholstered product as well as for the instructions regarding maintenance and washing.

Cuscini decorativi Decorative cushions

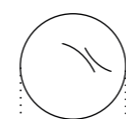

Ø38
Ø15"

Ø38
Ø15"

Cuscino decorativo in fibra poliестere e chiusura con cerniera.

Decorative polyester fibre cushion with zip closure.

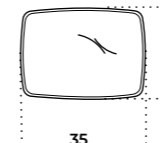

35

35 x 25
14" x 10"

Cuscino decorativo in fibra poliестere rifinito con bordo perimetrale e chiusura con cerniera.

Decorative polyester fibre cushion finished with perimetral trim and zip closure.

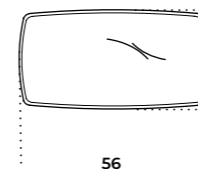

56

56 x 28
22 1/4" x 11 1/4"

Cuscino decorativo in fibra poliестere rifinito con bordo perimetrale e chiusura con cerniera.

Decorative polyester fibre cushion finished with perimetral trim and zip closure.

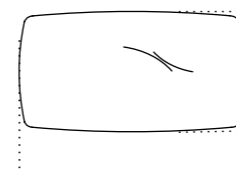

70

70 x 38
27 3/4" x 15"

Cuscino decorativo in fibra poliестere e chiusura con cerniera.

Decorative polyester fibre cushion with zip closure.

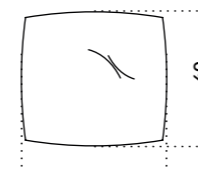

40

40 x 40
15 3/4" x 15 3/4"

Cuscino decorativo in fibra poliестere e chiusura con cerniera.

Decorative polyester fibre cushion with zip closure.

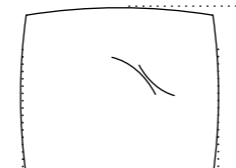

60

60 x 60
23 3/4" x 23 3/4"

Cuscino decorativo in fibra poliестere e chiusura con cerniera.

Decorative polyester fibre cushion with zip closure.

Audrey Pouf | Massimo Castagna, 2019

Product information / p.124

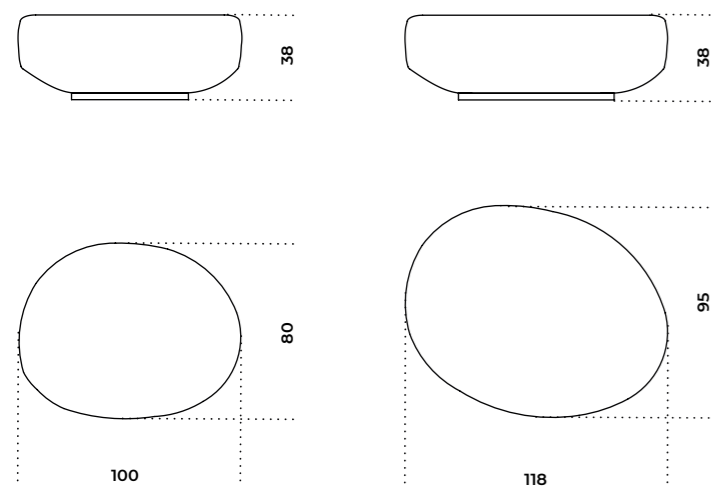
**Lou** | Studio G&R, 2015

Product information / p.130

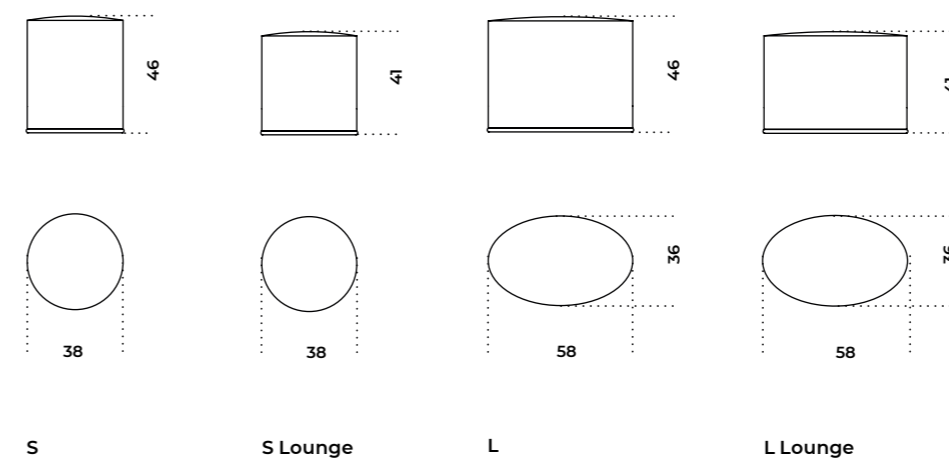
**Cloud Pouf** | Massimo Castagna, 2017

Product information / p.126

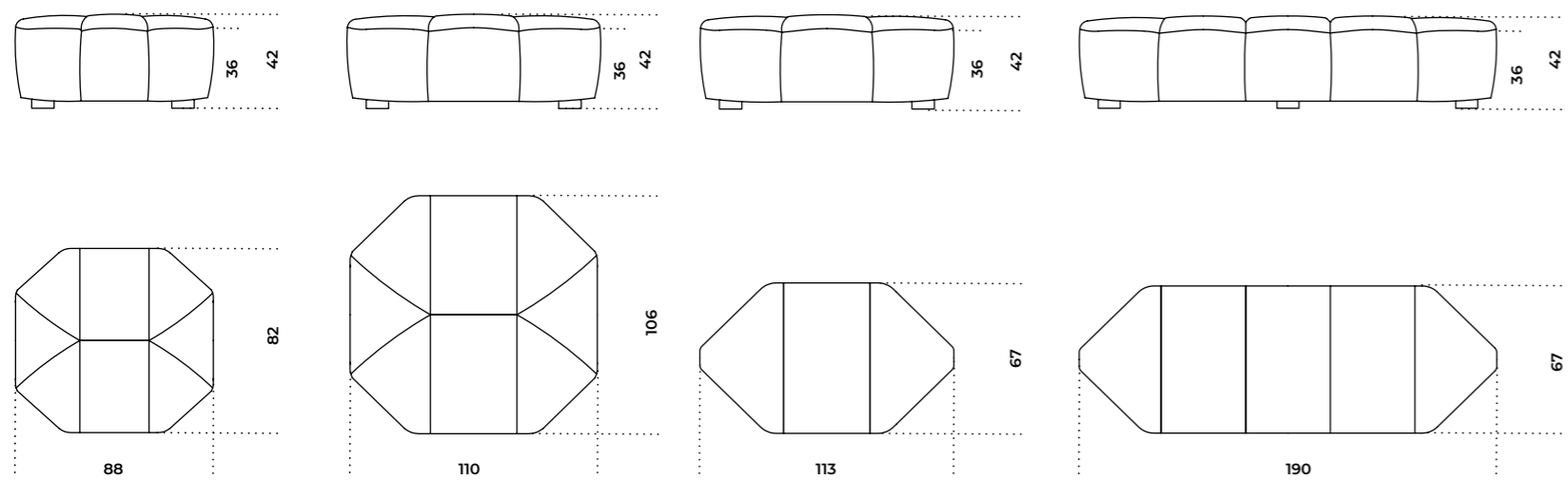
**Oly** | Massimo Castagna, 2019

Product information / p.132

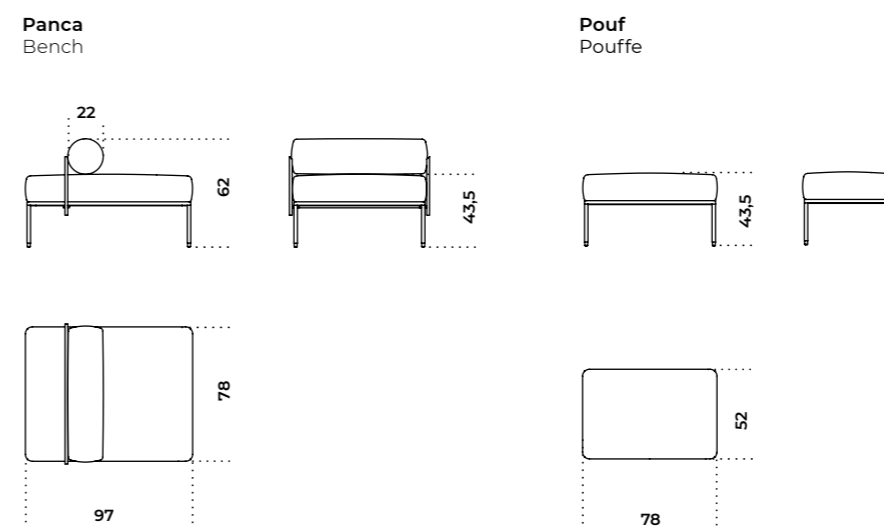
**Lilas Bench** | Dainelli Studio, 2022

Product information / p.128

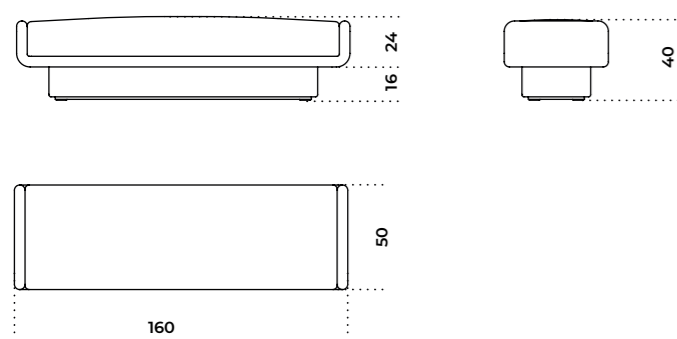

Tavolino S (50 x 25 x 22h)
Side table S (19 3/4" x 10" x 8 3/4"h)

Tavolino M (50 x 35 x 22h)
Side table M (19 3/4" x 14" x 8 3/4"h)

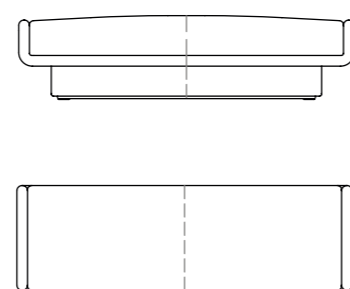

Posizione cuciture per versione in pelle/pelle scamosciata
Stitching position for leather/suede version

**Stami Bench** | Studioepepe, 2022

Product information / p.134

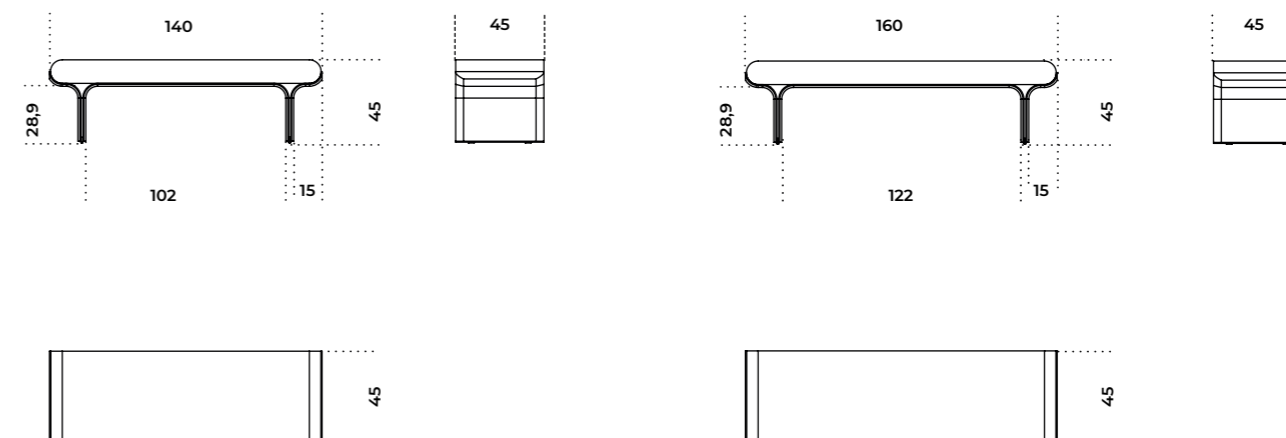

Stami Day Bed | Studiopepe, 2022

[Product information / p. 136](#)

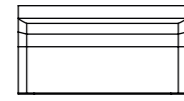
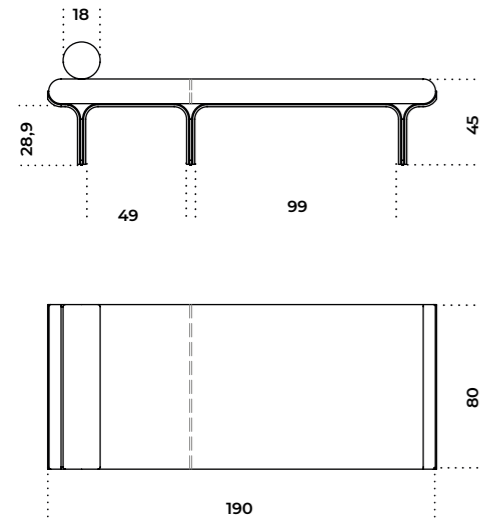

Stami Pouf | Studiopepe, 2022

[Product information / p. 138](#)

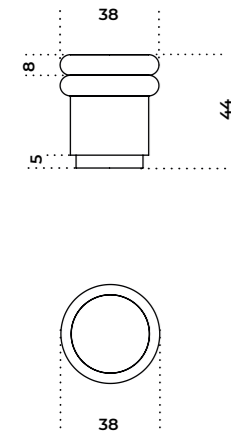

Twelve-Day Bed | Massimo Castagna, 2016

[Product information / p. 140](#)

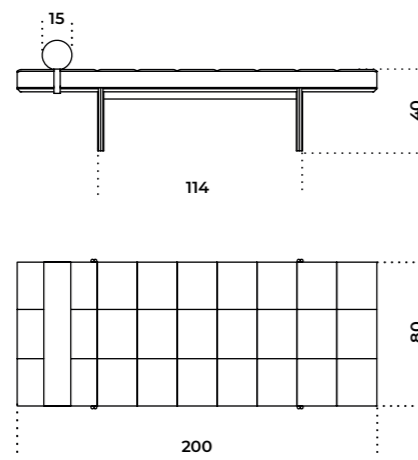
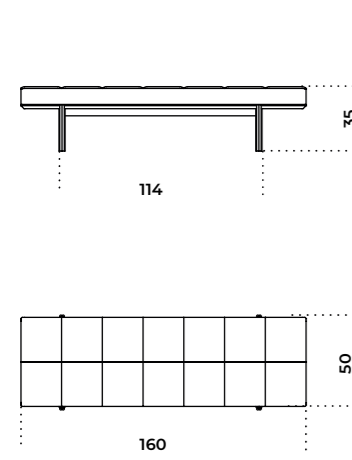

05 Divani e poltrone /

Sofas and armchairs

152	0417
154	Akiko Lounge
156	Audrey
158	Audrey Motion
160	Audrey Poltrona
162	Cloud
164	Cloud Infinity
166	Cloud Poltrona
168	Elissa
170	Elissa Sectional
174	Fiona
176	Fiona Soft
178	First
180	First Modulare
182	First Poltrona & Pouf
184	Lilas
186	Lilas Mosaique
188	Livre
190	Sophie
192	Sophie Sofa
194	Stami Lounge
196	Informazioni tecniche/ Technical informations



0417

Studio G&R / 2017

Poltroncina con struttura in massello di frassino curvato tinto nero poro aperto. Disponibile anche in frassino naturale, tinto tabacco, tinto bianco poro aperto o tinto grigio smoke poro aperto. Seduta e schienale, in multistrato curvato con imbottitura in poliuretano espanso, rivestiti in tessuto o pelle nei colori del campionario.

Armchair with black stained open pore solid curved ash structure. Also available in natural ash, tobacco stained or white open pore stained ash. Curved plywood seat and backrest with polyurethane foam padding covered by fabric or leather as per sample.

! Non sfoderabile.

Per la realizzazione di elementi con rivestimento in pelle sono necessarie cuciture aggiuntive rispetto gli elementi con rivestimento in tessuto.

Il massello di frassino naturale presenta variazioni di colore che vanno dal biondo chiaro al rosa fino ad arrivare al bruno pallido, con eventuali sfumature di verde. Queste differenze sono da considerarsi caratteristiche di questa essenza.

Il legno massello è molto sensibile alla luce, il posizionamento vicino a sorgenti di luce naturale ne compromette la colorazione e la stabilità. Un'elevata variazione della temperatura e umidità dell'aria può provocare la comparsa di microfratture e leggere variazioni.

! Not removable cover.

Additional stitching is required for elements with leather upholstery compared to elements with fabric upholstery.

Natural ash solid wood has colour variations ranging from light blonde to pink to pale brown, with possible shades of green. These differences are to be considered characteristic of this essence.

Solid wood is very light-sensitive, placing it near natural light sources may compromise its colour and stability. Considerable differences in air temperature and humidity may cause microfractures and slight variations.



Cm
70 x 64 x 64

Inches
27¾" x 25¼" x 25¼"

[For technical drawing / p. 200](#)

[Pricelist 2023 / p. 71](#)
[Homescapes, gentle attitude / pp. 21, 22, 24, 25](#)

STRUTTURA/STRUCTURE

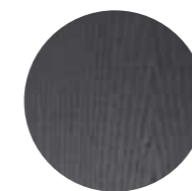

Frassino tinto nero poro aperto
Black stained open pore ash



Frassino naturale
Natural ash

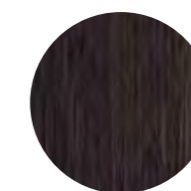

Frassino tinto tabacco
Tobacco stained ash



Frassino tinto bianco poro aperto
White open pore stained ash



Frassino tinto grigio smoke poro aperto
Grey smoke open pore stained ash



Tessuto/pelle nei colori del campionario
Fabric/leather as per samples.

RIVESTIMENTO/COVER



• AKIKO LOUNGE
Rivestimento in Futura milk 002
Cover in Futura milk 002

Akiko Lounge

Oscar e Gabriele Buratti / 2017

Poltrona con struttura interna in metallo imbottita con schiuma poliuretana a densità differenziate e fibra poliestere. Basamento in metallo verniciato color "warm grey". Rivestimento sfoderabile in tessuto o pelle nei colori del campionario.

Disponibile versione con movimento girevole a 180° con ritorno con basamento a 4 razze in metallo verniciato color "warm grey" con finalini.

! Rivestimento sfoderabile

Per la realizzazione di elementi con rivestimento in pelle sono necessarie cuciture aggiuntive rispetto gli elementi con rivestimento in tessuto.

Armchair with metal inside structure padded with polyurethane foam in different density and polyester fibre. Metal base lacquered in the "warm grey" colour. Removable cover in fabric or leather as per samples.

Also available version with 180° swivel movement with return with "warm grey" colour lacquered four star metal base with feet.

! Removable cover

Additional stitching is required for elements with leather upholstery compared to elements with fabric upholstery.



Cm
78,5 x 83,5 x 70

Inches
31¾" x 33" x 27¾"

[For technical drawing / p. 200](#)

[Pricelist 2023 / p. 72](#)
[Homescapes, gentle attitude / pp. 45, 48, 72, 74](#)

**BASE METALLICA/
METAL BASE**



Metallo verniciato
"warm grey"
Metal lacquered
"warm grey" colour

RIVESTIMENTO/COVER



Tessuto/pelle nei colori
del campionario
Fabric/leather as per
samples.



• **AUDREY**
 Rivestimento in velvet Ochre 1688
 Cover in velvet Ochre 1688

Audrey

Massimo Castagna / 2017

Divano in poliuretano espanso indeformabile a densità differenziate e fibra poliestere con struttura interna in legno e derivati. Basamento in MDF in massa nero. Disponibile con rivestimento in tessuto o pelle nei colori del campionario. Fornito di due cuscini schienale in fibra poliestere. Cuscini decorativi in fibra poliestere, su richiesta.

! Su richiesta rivestimento sfoderabile escluso in Cat. L1, L2 e pelle cliente/C.O.L.

Per la realizzazione di elementi con rivestimento in pelle sono necessarie cuciture aggiuntive rispetto gli elementi con rivestimento in tessuto.

Disponibile versione destra o sinistra.
 La scelta della versione destra o sinistra è da specificare al momento dell'ordine.

Sofa in non-deformable polyurethane foam in different density and polyester fibre with inside structure in wood and by-products. Black coloured MDF base. Available covered by fabric or leather as per sample. Supplied with two backrest cushions in polyester fibre. Decorative polyester fibre cushions, on request.

! On demand removable cover excluding in Cat. L1, L2 and client supplied leather.

Additional stitching is required for elements with leather upholstery compared to elements with fabric upholstery.

Available right or left version.
 The right or left version has to be confirmed when ordering.



Cm

207 x 109 x 73
 252 x 116 x 73
 278 x 123 x 73
 326 x 137 x 73

Inches

81½" x 43" x 28¾"
 99¾" x 45¾" x 28¾"
 109½" x 48½" x 28¾"
 128½" x 54" x 28¾"

Cuscino schienale (incluso):

45 x 6 x 41 (Audrey 207)
 67 x 6 x 41 (Audrey 252)
 71 x 6 x 41 (Audrey 278)
 83 x 6 x 41 (Audrey 326)

Backrest cushion (included):

17¾" x 2½" x 16¼" (Audrey 207)
 26½" x 2½" x 16¼" (Audrey 252)
 28" x 2½" x 16¼" (Audrey 278)
 32¾" x 2½" x 16¼" (Audrey 326)

Cuscino decorativo

40 x 40
 60 x 60

Decorative cushion

15¾" x 15¾"
 23¾" x 23¾"

[For technical drawing / p.201](#)

[Pricelist 2023 / p.73](#)
[Homescapes, sense of materials / p.8](#)
[Homescapes, intimate portraits / p.65](#)
[Homescapes, gentle attitude / pp.92,93](#)

RIVESTIMENTO/COVER



Tessuto/pelle nei colori del campionario
 Fabric/leather as per samples.



Audrey Motion

Massimo Castagna / 2020

Divano modulare in poliuretano espanso indeformabile a densità differenziate e fibra poliestere con struttura interna in legno e derivati. Basamento in MDF in massa nero. Disponibile con rivestimento in tessuto o pelle nei colori del campionario. Fornito di cuscini schienale in fibra poliestere. Cuscini decorativi in fibra poliestere su richiesta.

! Rivestimento sfoderabile escluso in Cat. L1, L2 e pelle cliente/C.O.L.

Per la realizzazione di elementi con rivestimento in pelle sono necessarie cuciture aggiuntive rispetto gli elementi con rivestimento in tessuto

I divani componibili sono dotati di un pratico sistema di aggancio che garantisce il fissaggio dei moduli.

Moduli non vendibili singolarmente.

Modular in non-deformable polyurethane foam in different density and polyester fibre with inside structure in wood and by-products. Black coloured MDF base. Available covered by fabrics or leathers as per samples. Supplied with backrest cushions in polyester fibre. Decorative cushions in polyester fibre on request.

! Removable cover excluding in Cat. L1, L2 and client supplied leather.

Additional stitching is required for elements with leather upholstery compared to elements with fabric upholstery.

The modular sofas are supplied with a coupling system that guarantees the fixing of the modules.

Modules cannot be sold individually.



Cm

Moduli terminali:
115 x 113 x 73 (T115L/R)
160 x 140 x 73 (T160L/R)

Moduli centrali:

175 x 107 x 73 (C175)
200 x 105 x 73 (C200)
235 x 113 x 73 (C235)

Cuscino schienale (incluso):
65 x 6 x 40

Cuscino decorativo
40 x 40
60 x 60

Inches

Terminal modules:
45½" x 44½" x 28¾" (T115L/R)
63" x 55½" x 28¾" (T160L/R)

Central modules:

69" x 42¼" x 28¾" (C175)
78¾" x 41½" x 28¾" (C200)
92¾" x 44½" x 28¾" (C235)

Backrest cushion (included):
25¾" x 2½" x 15¾"

Decorative cushion
15¾" x 15¾"
23¾" x 23¾"

[For technical drawing / p. 202-203](#)

[Pricelist 2023 / p. 75](#)
[Homescapes, embracing beauty / p. 82](#)

RIVESTIMENTO/COVER



Tessuto/pelle nei colori del campionario
Fabric/leather as per samples.

Audrey Poltrona

Massimo Castagna / 2018

Poltrona girevole (360°) in poliuretano espanso indeformabile a densità differenziate e fibra poliestere con struttura interna legno. Fornita di un cuscino schienale in fibra poliestere. Basamento in MDF in massa nero.
Disponibile con rivestimento in tessuto o pelle nei colori del campionario.
Cuscino decorativo in fibra poliestere, su richiesta.

Swivel armchair (360°) in non-deformable foam polyurethane in different densities and polyester fibre with wooden inside structure. A polyester fibre back cushion included.
Black coloured MDF base.
Available covered by fabric or leather as per sample.
Decorative polyester fibre cushion, on request.

! Su richiesta rivestimento sfoderabile escluso in Cat. L1, L2 e pelle cliente/C.O.L.

Per la realizzazione di elementi con rivestimento in pelle sono necessarie cuciture aggiuntive rispetto gli elementi con rivestimento in tessuto.
Disponibile versione destra o sinistra.

La scelta della versione destra o sinistra è da specificare al momento dell'ordine.

! On demand removable cover excluding in Cat. L1, L2 and client supplied leather.

Additional stitching is required for elements with leather upholstery compared to elements with fabric upholstery.

Available right or left version.
The right or left version has to be confirmed when ordering.



Cm

102 x 84 x 68
122 x 97 x 68

Cuscino schienale (incluso):
50 x 6 x 40

Cuscino decorativo
40 x 40

Inches

40 1/4" x 33 1/4" x 27"
48 1/4" x 38 1/4" x 27"

Backrest cushion (included):
19 3/4" x 2 1/2" x 15 3/4"

Decorative cushion
15 3/4" x 15 3/4"

[For technical drawing / p. 204](#)

[Pricelist 2023 / p. 79](#)
[Homescapes, sense of materials / p. 10](#)
[Homescapes, embracing beauty / p. 82](#)

RIVESTIMENTO/COVER



Tessuto/pelle nei colori del campionario
Fabric/leather as per samples.



Cloud

Massimo Castagna / 2016

Divano in poliuretano espanso indeformabile a densità differenziate e fibra poliestere con struttura interna in legno. Piedi in legno laccato nero. Disponibile con rivestimento in tessuto o pelle nei colori del campionario. Cuscini decorativi in fibra poliestere, su richiesta.

! Non sfoderabile.

Per la realizzazione di elementi con rivestimento in pelle sono necessarie cuciture aggiuntive rispetto gli elementi con rivestimento in tessuto.

Sofa in non-deformable foam polyurethane in different density and polyester fibre with wooden inside structure. Black lacquered wooden feet. Available covered by fabric or leather as per samples. Decorative polyester fibre cushions, on request.

! Not removable cover

Additional stitching is required for elements with leather upholstery compared to elements with fabric upholstery.



Cm

140 x 100 x 75
220 x 100 x 75
260 x 100 x 75

Cuscino decorativo

40 x 40
60 x 60

Inches

55¼" x 39½" x 29¾"
86¾" x 39½" x 29¾"
102½" x 39½" x 29¾"

Cuscino decorativo

15¾" x 15¾"
23¾" x 23¾"

[For technical drawing / p. 204](#)

[Pricelist 2023 / p. 80](#)
[Homescapes, intimate portraits / p. 106](#)
[Homescapes, gentle attitude / pp. 72, 74](#)

RIVESTIMENTO/COVER



Tessuto/pelle nei colori del campionario
Fabric/leather as per samples.



▲ **CLOUD INFINITY**
 Rivestimento in Touch milk 111
 Cover in Touch milk 111

Cloud Infinity

Massimo Castagna / 2022

Divano modulare in poliuretano espanso indeformabile a densità differenziate e fibra poliestere con struttura interna in legno. Piedi in legno laccato nero. Disponibile con rivestimento in tessuto o pelle nei colori del campionario. Non sfoderabile. Tavolino in legno laccato color fango disponibile su richiesta. Disponibile anche con top in marmo Travertino Romano spazzolato naturale (non resinato), Calacatta Vagli Oro lucido naturale o Emperador Brown spazzolato.

! Non sfoderabile.
 Su richiesta rivestimento sfoderabile escluso Cat. L1, L2 e pelle cliente/C.O.L.

Per la realizzazione di elementi con rivestimento in pelle sono necessarie cuciture aggiuntive rispetto gli elementi con rivestimento in tessuto.

Moduli non vendibili singolarmente.

Modular sofa in non-deformable foam polyurethane in different density and polyester fibre with wooden inside structure. Black lacquered wooden feet. Available covered by fabric or leather as per samples. Not removable cover. Fango lacquered wooden side table on request. Also available with natural brushed Travertino Romano (not treated with resin), natural polish Calacatta Vagli Oro or brushed Emperador Brown marble top.

! Not removable cover.
 On demand removable covers excluding Cat. L1, L2 and customer leather C.O.L.

Additional stitching is required for elements with leather upholstery compared to elements with fabric upholstery.

Modules cannot be sold individually.



Cm
Moduli terminali:
 76 x 100 x 75 (T1 L/R)
 114 x 100 x 75 (T2 L/R)
 170 x 100 x 75 (T3 L/R)

Moduli centrali:
 76 x 100 x 75 (C2)
 114 x 100 x 75 (C3)
 152 x 165 x 75 (TCL)

Moduli angolari:
 170 x 124 x 75 (TA L/R)
 140 x 124 x 75 (CA)

Tavolino:
 100 x 40 x 35

Cuscino decorativo
 40 x 40
 60 x 60

Inches
Terminal modules:
 30" x 39½" x 29¾" (T1 L/R)
 45" x 39½" x 29¾" (T2 L/R)
 60" x 39½" x 29¾" (T3 L/R)

Central modules:
 30" x 39½" x 29¾" (C2)
 45" x 39½" x 29¾" (C3)
 60" x 65" x 29¾" (TCL)

Corner modules:
 67" x 49" x 29¾" (TA L/R)
 55½" x 49" x 29¾" (CA)

Side table:
 39½" x 15¾" x 14

Decorative cushion
 15¾" x 15¾"
 23¾" x 23¾"

[For technical drawing / p. 205-209](#)

[Pricelist 2023 / p. 81](#)
[Homescapes, gentle attitude / pp. 21, 24, 25, 72, 73, 76, 78](#)

RIVESTIMENTO/COVER



Tessuto/pelle nei colori del campionario
 Fabric/leather as per samples.

PIEDINI/FEET



Legno laccato nero
 Black lacquered wood

TAVOLINO/SIDE TABLE
 BASE / BASE

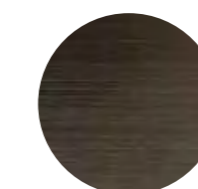

Legno laccato color "fango"
 Wooden lacquered "fango" colour

TAVOLINO/SIDE TABLE
 TOP



Travertino Romano
 spazzolato naturale
 Natural brushed
 Travertino Romano



Marmo lucido naturale
 Calacatta Vagli Oro
 Natural polished
 Calacatta Vagli Oro marble



Marmo spazzolato
 Emperador Brown
 Brushed Emperador
 Brown marble

Cloud Poltrona

Massimo Castagna / 2016

Poltrona in poliuretano espanso indeformabile a densità differenziate e fibra poliestere con struttura interna in legno. Piedi in legno laccato nero. Disponibile con rivestimento in tessuto o pelle nei colori del campionario. Cuscini decorativi in fibra poliestere, su richiesta.

Armchair in non-deformable foam polyurethane in different density and polyester fibre with wooden inside structure. Black lacquered wooden feet. Available covered by fabric or leather as per sample. Decorative polyester fibre cushions, on request.

! Non sfoderabile.

! Not removable cover.

Per la realizzazione di elementi con rivestimento in pelle sono necessarie cuciture aggiuntive rispetto gli elementi con rivestimento in tessuto.

Additional stitching is required for elements with leather upholstery compared to elements with fabric upholstery.



Cm
110 x 100 x 75

Cuscino decorativo
40 x 40
60 x 60

Inches
43½" x 39½" x 29¾"

Decorative cushion
15¾" x 15¾"
23¾" x 23¾"

[For technical drawing / p.210](#)

[Pricelist 2023 / p.87](#)
[Homescapes, gentle attitude / p.21](#)

RIVESTIMENTO/COVER



Tessuto/pelle nei colori del campionario
Fabric/leather as per samples.

Elissa

Dainelli Studio / 2020

Divano con struttura interna in legno e derivati. Imbottito con poliuretano espanso indeformabile a densità differenziate e fibra poliestere. Cucitura orizzontale perimetrale esterna. Cuscini schienale in piuma inclusi. Basamento in legno laccato color "fango". Disponibile con rivestimento in tessuto o pelle nei colori del campionario. Cuscini decorativi imbottiti in fibra poliestere, su richiesta.

Sofa with inside structure in wood and by-products. Padded with non-deformable foam polyurethane in different densities and polyester fibre. Horizontal stitching along the external perimeter. Downpadding backrest cushions included. Wooden base lacquered in the "fango" colour. Available covered by fabrics or leathers as per samples. Decorative cushions in polyester fibre on request.

! Rivestimento sfoderabile.

Per la realizzazione di elementi con rivestimento in pelle sono necessarie cuciture aggiuntive rispetto gli elementi con rivestimento in tessuto.

! Removable cover.

Additional stitching is required for elements with leather upholstery compared to elements with fabric upholstery.



Cm

240 x 96 x 69
280 x 96 x 69

Inches

94½" x 38" x 27¼"
110¼" x 38" x 27¼"

Cuscino schienale (incluso): 60 x 60

Cuscino decorativo
40 x 40
60 x 60

Backrest cushion (included): 23¾" x 23¾"

Decorative cushion
15¾" x 15¾"
23¾" x 23¾"

For technical drawing / p.210

Pricelist 2023 / p. 88
Homescapes, embracing beauty / p. 25
Homescapes, gentle attitude / pp. 37, 39

BASE/BASE

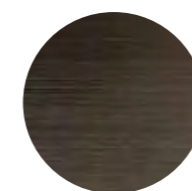

Legno laccato color "fango"
Wooden lacquered "fango"
colour

RIVESTIMENTO/COVER



Tessuto/pelle nei colori del campionario
Fabric/leather as per samples.

▲ ELISSA
Rivestimento in della milk 002 / Base in legno laccato color "fango"
Cover in della milk 002 / Wooden lacquered "fango" colour base

Elissa Sectional

Dainelli Studio / 2021

Divano modulare con struttura interna in legno e derivati. Imbottito con poliuretano espanso indeformabile a densità differenziate e fibra poliestere. Cucitura orizzontale perimetrale esterna. Cuscini schienale in piuma inclusi. Basamento in legno laccato color "fango". Disponibile con rivestimento in tessuto o pelle nei colori del campionario.

Modular sofa with inside structure in wood and by-products. Padded with non-deformable foam polyurethane in different densities and polyester fiber. Horizontal stitching along the external perimeter. Downpadding backrest cushions included. Wooden base lacquered in the "fango" colour. Available covered by fabric or leather as per samples.

! Rivestimento sfoderabile.

Per la realizzazione di elementi con rivestimento in pelle sono necessarie cuciture aggiuntive rispetto gli elementi con rivestimento in tessuto.

I divani componibili sono dotati di un pratico sistema di aggancio che garantisce il fissaggio dei moduli.

Moduli non vendibili singolarmente.

! Removable cover.

Additional stitching is required for elements with leather upholstery compared to elements with fabric upholstery.

The modular sofas are supplied with a coupling system that guarantees the fixing of the modules.

Modules cannot be sold individually.



Cm

Moduli terminali:

120 x 96 x 69 (ELS-T120L/R)
140 x 96 x 69 (ELS-T140L/R)
220 x 96 x 69 (ELS-T200L/R)
260 x 96 x 69 (ELS-T260L/R)

Moduli centrali:

100 x 90 x 69 (ELS-C100)
120 x 90 x 69 (ELS-C120)
200 x 90 x 69 (ELS-C200)
240 x 90 x 69 (ELS-C240)

Moduli angolari:

225 x 147 x 69 (ELS-TA225L/R)
240 x 120 x 69 (ELS-TA240L/R)
280 x 120 x 69 (ELS-TA280L/R)
200 x 147 x 69 (ELS-CA200)
140 x 120 x 69 (ELS-A140L/R)

Cuscino schienale (incluso):

60 x 60

Cuscino decorativo

40 x 40
60 x 60

Inches

Terminal modules:

47¼" x 38" x 27¼" (ELS-T120L/R)
55¼" x 38" x 27¼" (ELS-T140L/R)
86¾" x 38" x 27¼" (ELS-T220L/R)
120½" x 38" x 27¼" (ELS-T260L/R)

Central modules:

39½" x 35½" x 27¼" (ELS-C100)
47¼" x 35½" x 27¼" (ELS-C120)
78¾" x 35½" x 27¼" (ELS-C200)
94½" x 35½" x 27¼" (ELS-C240)

Corner modules:

88¾" x 58" x 27¼" (ELS-TA225L/R)
94½" x 47¼" x 27¼" (ELS-TA240L/R)
110¼" x 47¼" x 27¼" (ELS-TA280L/R)
78¾" x 58" x 27¼" (ELS-CA200)
55¼" x 47¼" x 27¼" (ELS-A140L/R)

Backrest cushion (included):

23¾" x 23¾"

Decorative cushion

15¾" x 15¾"
23¾" x 23¾"

[For technical drawing / p. 211-215](#)

[Pricelist 2023 / p. 89](#)
[Homesapes, intimate portraits / pp. 17, 24](#)

• ELISSA SECTIONAL
Rivestimento in joy grey 007 / Base in legno laccato color "fango"
Cover in joy grey 007 / Wooden lacquered "fango" colour base

BASE/BASE

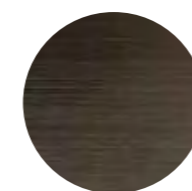

Legno laccato color "fango"
Wooden lacquered "fango" colour

RIVESTIMENTO/COVER



Tessuto/pelle nei colori del campionario
Fabric/leather as per samples.

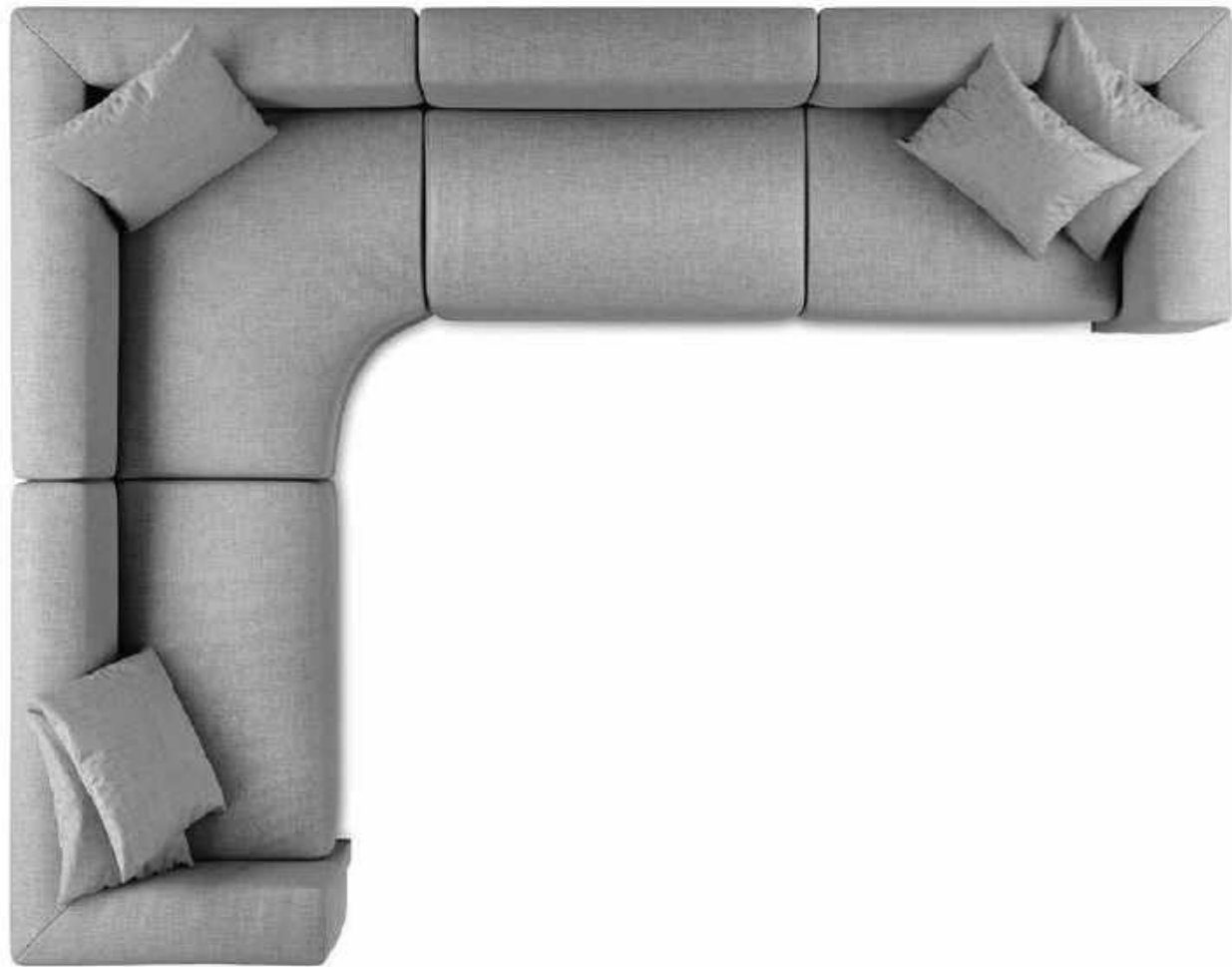

COMPOSITION 3

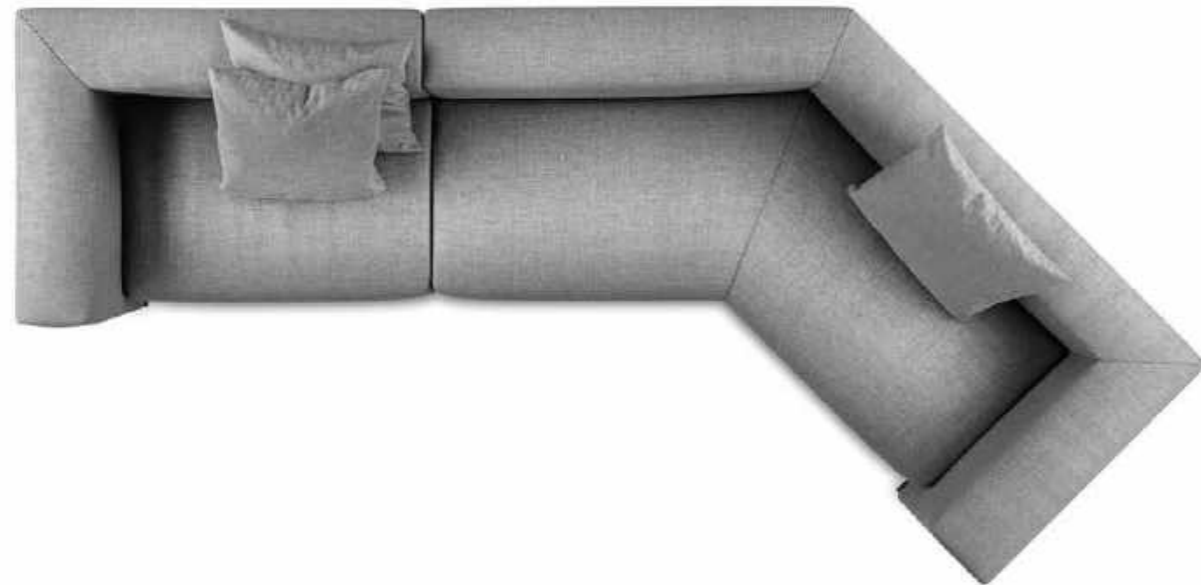

COMPOSITION 4

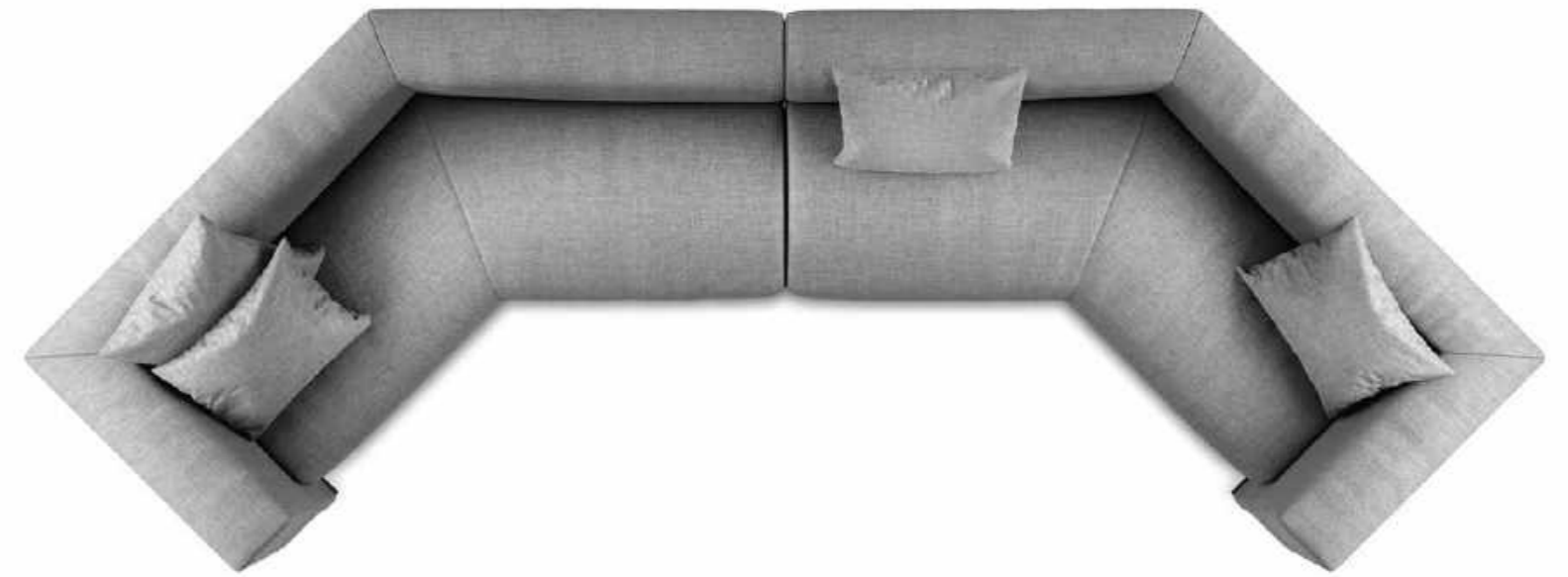

COMPOSITION 6

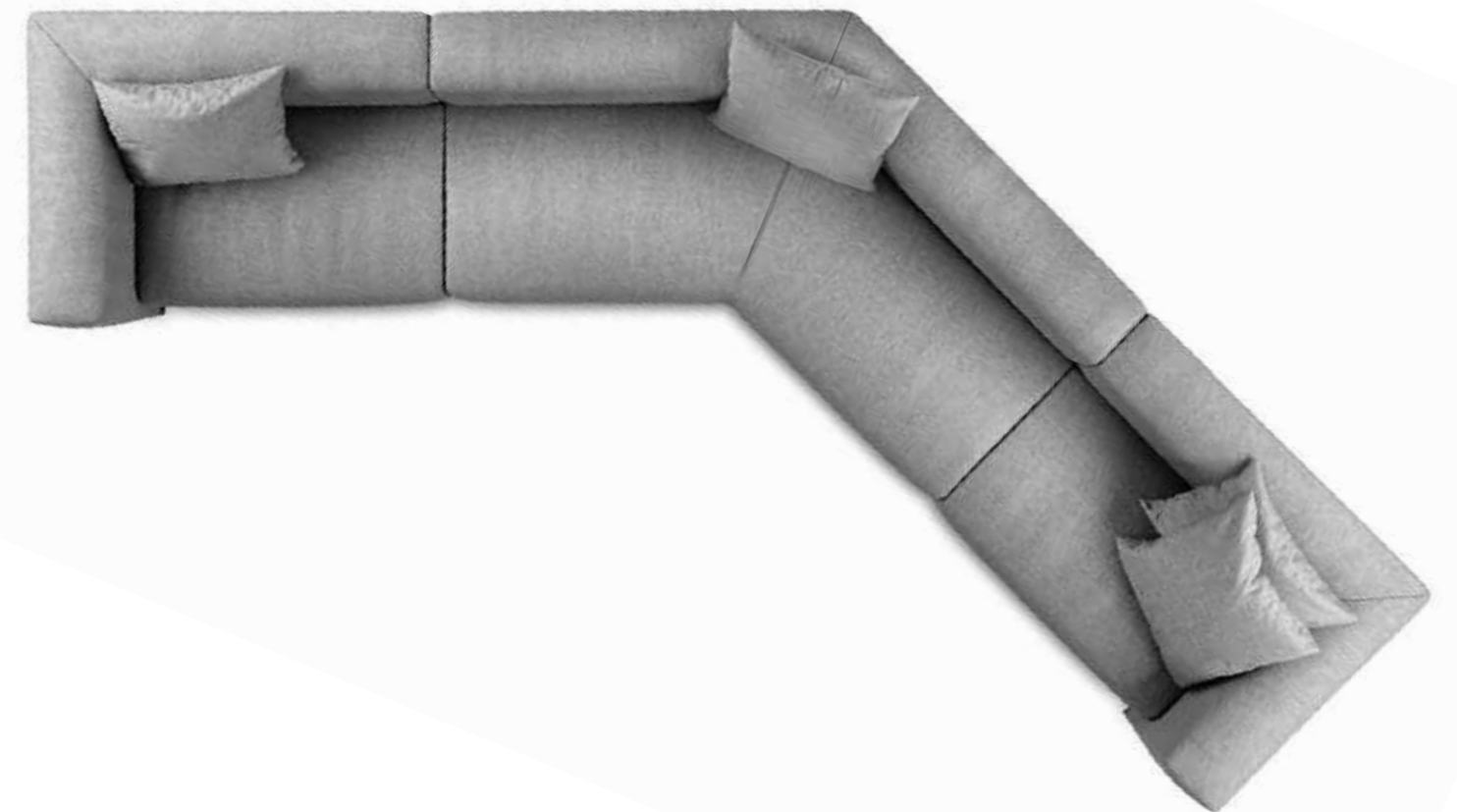

COMPOSITION 5



▲ **FIONA**
Modulo divano (modulo BL) cm 170 x 100 x 71h / Rivestimento in velvet mink 518
Modular sofa (BL module) inches 67" x 39½" x 28"h / Cover in velvet mink 518

Fiona

Massimo Castagna / 2018

Divano modulare in poliuretano espanso indeformabile a densità differenziate e fibra poliestere con struttura interna in legno. Appoggio a terra su piedini in materiale termoplastico. Schienale lavorato in capitonné. Cuscini schienale misto piuma. Disponibile con rivestimento in tessuto o pelle nei colori del campionario. Cuscini decorativi in fibra poliestere, su richiesta.

! Non sfoderabile.

Per la realizzazione di elementi con rivestimento in pelle sono necessarie cuciture aggiuntive rispetto gli elementi con rivestimento in tessuto.

I divani componibili sono dotati di un pratico sistema di aggancio che garantisce il fissaggio dei moduli.

Moduli non vendibili singolarmente.

Modular sofa in non-deformable foam polyurethane in different density and polyester fibre with wooden inside structure. Rests on feet made of thermoplastic material. Capitonné back. Mixed down padding backrest cushions. Available covered by fabric or leather as per sample. Decorative polyester fibre cushions, on request.

! Not removable cover.

Additional stitching is required for elements with leather upholstery compared to elements with fabric upholstery.

The modular sofas are supplied with a coupling system that guarantees the fixing of the modules.

Modules cannot be sold individually.



	Cm Moduli	Inches Modules
A-130 L/R	130 x 110 x 71	51¼" x 43½" x 28"
A-180 L/R	180 x 110 x 71	71" x 43½" x 28"
A-230 L/R	230 x 110 x 71	90¾" x 43½" x 28"
B-180 L/R	180 x 110 x 71	71" x 43½" x 28"
B-230 L/R	230 x 110 x 71	90¾" x 43½" x 28"
C-180L/R	180 x 110 x 71	71" x 43½" x 28"
C-230L/R	230 x 110 x 71	90¾" x 43½" x 28"
D-130	130 x 110 x 71	51¼" x 43½" x 28"
D-180	180 x 110 x 71	71" x 43½" x 28"
D-230	230 x 110 x 71	90¾" x 43½" x 28"
E-180 L/R	180 x 110 x 71	71" x 43½" x 28"
F-110 L/R	110 x 180 x 71	43½" x 71" x 28"
G-110	110 x 180 x 71	43½" x 71" x 28"

Cuscino schienale (incluso): 83 x 6 x 47
Backrest cushion (included): 32¾" x 2½" 18¾"

Cuscino decorativo
40 x 40
60 x 60

Decorative cushion
15¾" x 15¾"
23¾" x 23¾"

[For technical drawing / p.216](#)

[Pricelist 2023 / p.96](#)

RIVESTIMENTO/COVER



Tessuto/pelle nei colori del campionario
Fabric/leather as per samples.

Fiona Soft

Massimo Castagna / 2019

Divano modulare in poliuretano espanso indeformabile a densità differenziate e fibra poliestere con struttura interna in legno. Appoggio a terra su piedini in materiale termoplastico. Schienale con cuciture lineari verticali. Cuscini schienale misto piuma. Disponibile con rivestimento in tessuto o pelle nei colori del campionario. Cuscini decorativi in fibra poliestere, su richiesta.

! Non sfoderabile.

Per la realizzazione di elementi con rivestimento in pelle sono necessarie cuciture aggiuntive rispetto agli elementi con rivestimento in tessuto.

I divani componibili sono dotati di un pratico sistema di aggancio che garantisce il fissaggio dei moduli.

Moduli non vendibili singolarmente.

Modular sofa in non-deformable foam polyurethane in different density and polyester fibre with wooden inside structure. Rests on feet made of thermoplastic material. Back with vertical linear seams. Mixed downpadding backrest cushions. Available covered by fabric or leather as per sample. Decorative polyester fibre cushions, on request.

! Not removable cover.

Additional stitching is required for elements with leather upholstery compared to elements with fabric upholstery.

The modular sofas are supplied with a coupling system that guarantees the fixing of the modules.

Modules cannot be sold individually.



	Cm Moduli	Inches Modules
A-130 L/R	130 x 110 x 71	51¼" x 43½" x 28"
A-180 L/R	180 x 110 x 71	71" x 43½" x 28"
A-230 L/R	230 x 110 x 71	90¾" x 43½" x 28"
B-180 L/R	180 x 110 x 71	71" x 43½" x 28"
B-230 L/R	230 x 110 x 71	90¾" x 43½" x 28"
C-180L/R	180 x 110 x 71	71" x 43½" x 28"
C-230L/R	230 x 110 x 71	90¾" x 43½" x 28"
D-130	130 x 110 x 71	51¼" x 43½" x 28"
D-180	180 x 110 x 71	71" x 43½" x 28"
D-230	230 x 110 x 71	90¾" x 43½" x 28"
E-180 L/R	180 x 110 x 71	71" x 43½" x 28"
F-110 L/R	110 x 180 x 71	43½" x 71" x 28"
G-110	110 x 180 x 71	43½" x 71" x 28"

Cuscino schienale (incluso) 83 x 6 x 47	Backrest cushion (included) 32¾" x 2½" 18¾"
Cuscino decorativo 40 x 40 60 x 60	Decorative cushion 15¾" x 15¾" 23¾" x 23¾"

For technical drawing / p. 217

Pricelist 2023 / p. 100
Homescapes, sense of materials / p. 88

RIVESTIMENTO/COVER



Tessuto/pelle nei colori del campionario
Fabric/leather as per samples.

▲ FIONA SOFT
Modulo divano (modulo AL) cm 170 x 100 x 71h / Rivestimento in nabuk rose powder 2104
Modular sofa (AL module) inches 67" x 39½" x 28"h / Cover in nabuk rose powder 2104



▲ **FIRST**
 Rivestimento in velvet Peacock 705
 Cover in velvet Peacock 705

First

Massimo Castagna / 2014

Divano in poliuretano espanso indeformabile a densità differenziate e fibra poliestere con struttura interna in legno. Piedi in legno laccato nero. Disponibile con rivestimento in tessuto o pelle nei colori del campionario. Su richiesta cuscini decorativi in fibra poliestere rifiniti con bordo perimetrale e chiusura con cerniera.

! Non sfoderabile.

Per la realizzazione di elementi con rivestimento in pelle sono necessarie cuciture aggiuntive rispetto gli elementi con rivestimento in tessuto.

Sofa in non-deformable foam polyurethane in different density and polyester fibre with wooden inside structure. Black lacquered wooden feet. Available covered by fabric or leather as per sample. On request decorative polyester fibre cushions finished with perimetral trim and zip closure.

! Not removable cover.

Additional stitching is required for elements with leather upholstery compared to elements with fabric upholstery.



Cm
 172 x 80 x 68

Cuscino decorativo
 35 x 25
 56 x 28
 40 x 40

Inches
 67¾" x 31½" x 27"

Decorative cushion
 14" x 10"
 22¼" x 11¼"
 15¾" x 15¾"

[For technical drawing / p. 218](#)

[Pricelist 2023 / p. 104](#)

RIVESTIMENTO/COVER



Tessuto/pelle nei colori del campionario
 Fabric/leather as per samples.

First Modulare

Massimo Castagna / 2015

Divano modulare in poliuretano espanso indeformabile a densità differenziate e fibra poliestere e piuma con struttura interna in legno. Piedi in legno laccato nero. Cuscini schienale misto piuma. Disponibile con rivestimento in tessuto o pelle nei colori del campionario. Su richiesta cuscini decorativi in fibra poliestere rifiniti con bordo perimetrale e chiusura con cerniera.

Modular sofa in non-deformable foam polyurethane in different density and polyester fibre and downpadding with wooden inside structure. Black lacquered wooden feet. Mixed downpadding backrest cushions. Available covered by fabric or leather as per sample. On request decorative polyester fibre cushions finished with perimetral trim and zip closure.

! Non sfoderabile.

Per la realizzazione di elementi con rivestimento in pelle sono necessarie cuciture aggiuntive rispetto gli elementi con rivestimento in tessuto.

I divani componibili sono dotati di un pratico sistema di aggancio che garantisce il fissaggio dei moduli.

Moduli non vendibili singolarmente.

! Not removable cover.

Additional stitching is required for elements with leather upholstery compared to elements with fabric upholstery.

The modular sofas are supplied with a coupling system that guarantees the fixing of the modules.

Modules cannot be sold individually.



Cm

107 x 98 x 68
167 x 98 x 68
207 x 98 x 68

Cuscino schienale (incluso):

73 x 40 (First modulare 107)
63 x 40 (First modulare 167)
73 x 40 (First modulare 207)

Cuscino decorativo

35 x 25
56 x 28
40 x 40

Inches

42¼" x 38¾" x 27"
65¾" x 38¾" x 27"
81½" x 38¾" x 27"

Backrest cushion (included):

28¾" x 15¾" (First modulare 107)
25" x 15¾" (First modulare 167)
28¾" x 15¾" (First modulare 207)

Decorative cushion

14" x 10"
22¼" x 11¼"
15¾" x 15¾"

[For technical drawing / p. 218](#)

[Pricelist 2023 / p. 105](#)

RIVESTIMENTO/COVER



Tessuto/pelle nei colori del campionario
Fabric/leather as per samples.

▲ **FIRST MODULARE**
Rivestimento in velvet Mink 518
Cover in velvet Mink 518



▲ FIRST POLTRONA&POUF
 Rivestimento in velvet Moss 7307
 Cover in velvet Moss 7307

First Poltrona & Pouf

Massimo Castagna / 2015

Poltrona e pouf in poliuretano espanso indeformabile a densità differenziate e fibra poliestere con struttura interna in legno. Piedi in legno laccato nero. Disponibile con rivestimento in tessuto o pelle nei colori del campionario. Su richiesta cuscini decorativi in fibra poliestere rifiniti con bordo perimetrale e chiusura con cerniera.

! Non sfoderabile.

Per la realizzazione di elementi con rivestimento in pelle sono necessarie cuciture aggiuntive rispetto gli elementi con rivestimento in tessuto.

Armchair and pouffe in non-deformable foam polyurethane in different density and polyester fibre with wooden inside structure. Black lacquered wooden feet. Available covered by fabric or leather as per sample.

On request decorative polyester fibre cushions finished with perimetral trim and zip closure.

! Not removable cover.

Additional stitching is required for elements with leather upholstery compared to elements with fabric upholstery.



Cm

Poltrona
 87 x 80 x 68
Pouf
 78 x 50 x 38

Cuscino decorativo
 35 x 25

Inches

Armchair
 34½" x 31½" x 27"
Pouffe
 30¾" x 19¾" x 15"

Decorative cushion
 14" x 10"

[For technical drawing / p. 218](#)

[Pricelist 2023 / p. 107](#)
[Homescapes, intimate portraits / pp. 89, 97](#)
[Homescapes, gentle attitude / p. 90](#)

RIVESTIMENTO/COVER



Tessuto/pelle nei colori del campionario
 Fabric/leather as per samples.



▲ LILAS
Rivestimento in Hope Rose powder 005
Cover in Hope Rose powder 005

Lilas

Dainelli Studio / 2021

Poltrona con struttura interna in legno e derivati, imbottita con poliuretano espanso indeformabile e fibra poliestere. Cuscino schienale e seduta imbottiti con poliuretano espanso indeformabile a densità differenziate e fibra poliestere. Disponibile in versione fissa o con movimento girevole a 180° con ritorno da specificare al momento dell'ordine. Disponibile con rivestimento in tessuto o pelle nei colori del campionario.

! Rivestimento sfoderabile.

Per la realizzazione di elementi con rivestimento in pelle sono necessarie cuciture aggiuntive rispetto gli elementi con rivestimento in tessuto.

Armchair with internal structure in wood and by-products. Padded with non-deformable foam polyurethane in different densities and polyester fibre. Backrest and seat cushions padded with non-deformable foam polyurethane in different densities and polyester fibre. Available in fixed version or with 180° swivel movement with return to be confirmed when ordering. Available covered by fabric or leather as per samples.

! Removable cover.

Additional stitching is required for elements with leather upholstery compared to elements with fabric upholstery.



Cm
70 x 70 x 72

Inches
27¾" x 27¾" x 28½"

[For technical drawing / p. 219](#)

[Pricelist 2023 / p. 108](#)
[Homescapes, intimate portraits / pp. 18, 24](#)
[Homescapes, gentle attitude / pp. 37, 39](#)

RIVESTIMENTO/COVER



Tessuto/pelle nei colori
del campionario
Fabric/leather as per
samples.

Lilas Mosaique

Dainelli Studio / 2022

Sistema di sedute componibili in poliuretano espanso indeformabile a densità differenziate e fibra poliestere. Piastra di base in metallo laccato nero. Disponibile con rivestimento sfoderabile in tessuto o pelle nei colori del campionario. Schienali zavorrati disponibili su richiesta. Gli schienali sono liberamente posizionabili e possono essere accompagnati da un cuscino 55x55 cm per rendere più confortevole la seduta. Cuscini decorativi in fibra poliestere su richiesta. Tavolini in metallo laccato color fango disponibili su richiesta.

Modular seating system in non-deformable polyurethane foam in different density and polyester fibre. Black lacquered metal base plate. Available with removable cover in fabric or leather as per samples. Ballasted backrest available on request. The backrests can be positioned as preferred and can be accompanied by 55x55cm cushion to make the seat more comfortable. Decorative polyester fibre cushion on request. Fango lacquered metal side table on request.

! Per la realizzazione di elementi con rivestimento in pelle sono necessarie cuciture aggiuntive rispetto gli elementi con rivestimento in tessuto.

! Additional stitching is required for elements with leather upholstery compared to elements with fabric upholstery.



	Cm Moduli	Inches Modules
LM-95X95	95 x 95 x 40	37½" x 37½" x 15¾"
LM-143X143	143 x 143 x 40	56½" x 56½" x 15¾"
LM-190X95	190 x 95 x 40	75" x 37½" x 15¾"
LM-275X95	275 x 95 x 40	108½" x 37½" x 15¾"

Schienale
80 x 26 x 30

Cuscino schienale (incluso)
55 x 8 x 55

Cuscino decorativo
40 x 40

Tavolino S
50 x 25 x 22

Tavolino M
50 x 35 x 22

Backrest
31½" x 10¾" x 12

Backrest cushion (included)
31¾" x 3¼" x 21¾"

Decorative cushion
15¾" x 15¾"

Side table S
19¾" x 10" x 8¾"

Side table M
19¾" x 14" x 8¾"

For technical drawing / p. 219-220

Pricelist 2023 / p.109
Homescapes, gentle attitude / pp. 41, 43, 103

RIVESTIMENTO/COVER



Tessuto/pelle nei colori del campionario
Fabric/leather as per samples.

PIASTRA DI BASE/ BASE PLATE

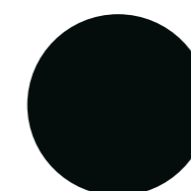

Legno laccato nero
Black lacquered wood

TAVOLINI/ SIDE TABLES

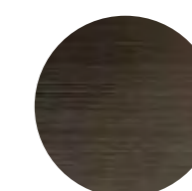

Metallo laccato color "fango"
Metal lacquered "fango" colour

▲ LILAS MOSAÏQUE
Rivestimento in Velvet peacock 705 / Tavolini in metallo laccato color "fango"
Cover in Velvet peacock 705 / Side table in metal lacquered "fango" colour

Livre

Federica Biasi / 2020

Poltrona con struttura interna in legno e derivati e parti metalliche. Imbottita con poliuretano espanso indeformabile a densità differenziate e fibra poliestere. Basamento in massello di frassino tinto nero poro aperto. Disponibile anche versione con movimento girevole a 360° con ritorno e basamento in acciaio verniciato nero rivestito in massello di frassino tinto nero poro aperto, da specificare al momento dell'ordine. Rivestimento in tessuto o pelle nei colori del campionario.

! Rivestimento sfoderabile.

Per la realizzazione di elementi con rivestimento in pelle sono necessarie cuciture aggiuntive rispetto gli elementi con rivestimento in tessuto.

Il legno massello è molto sensibile alla luce, il posizionamento vicino a sorgenti di luce naturale ne compromette la colorazione e la stabilità. Un'elevata variazione della temperatura e umidità dell'aria può provocare la comparsa di microfratture e leggere variazioni.

Armchair with internal structure in wood and by-products and metal parts. Padded with non-deformable foam polyurethane in different densities and polyester fibre. Solid wood base in black open pore stained ash. Also available version with 360° swivel movement with return and black painted steel structure covered by black open pore stained solid ash, to be confirmed when ordering. Available covered by fabric or leather as per samples.

! Removable cover.

Additional stitching is required for elements with leather upholstery compared to elements with fabric upholstery.

Solid wood is very light-sensitive, placing it near natural light sources may compromise its colour and stability. Considerable differences in air temperature and humidity may cause microfractures and slight variations.



Cm
85 x 74 x 66

Inches
33½" x 29¼" x 26"

[For technical drawing / p. 221](#)

[Pricelist 2023 / p. 112](#)
[Homescapes, embracing beauty / pp. 47, 100](#)
[Homescapes, intimate portraits / p. 102](#)
[Homescapes, gentle attitude / pp. 72, 73, 76, 104](#)

BASE/BASE

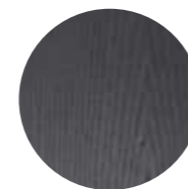

Frassino tinto nero poro aperto
Black open pore stained ash

RIVESTIMENTO/COVER



Tessuto/pelle nei colori del campionario
Fabric/leather as per samples.

▲ **LIVRE**
Rivestimento in Joy Rose powder 008
Cover in Joy Rose powder 008

Sophie

Federica Biasi / 2018

Poltrona con imbottitura in poliuretano espanso indeformabile a densità differenziate e fibra poliestere. Rivestimento in tessuto nei colori del campionario. Struttura in metallo laccato ottone satinato oppure grigio antracite.

Armchair with non-deformable polyurethane foam in different density and polyester fibre. Cover in fabric as per samples. Satin brass or anthracite grey lacquered metal structure.

! Bordo perimetrale nello stesso tessuto della poltrona. In caso di rivestimento in velluto il bordo perimetrale sarà realizzato in gros grain coordinandolo con il tessuto scelto per il rivestimento.

! Perimeter trim in the same fabric of the armchair. In case of velvet cover the perimeter trim will be in gros grain matching it with the fabric chosen for the piece.



Cm
115 x 95 x 70

Inches
45½" x 37½" x 27¾"

[For technical drawing / p. 221](#)

[Pricelist 2023 / p. 113](#)
[Homescapes, sense of materials / p. 19](#)
[Homescapes, gentle attitude / pp. 86, 87](#)

STRUTTURA/STRUCTURE



**Metallo laccato
ottone satinato**
Satin brass
lacquered metal

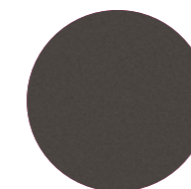

**Metallo laccato
grigio antracite**
Anthracite grey
lacquered metal

RIVESTIMENTO/COVER



**Tessuto nei colori
del campionario**
Fabric as per samples.

▲ **SOPHIE**
Struttura in metallo laccato ottone satinato / Rivestimento in velvet Ash Pink 2703
Satin brass structure / Cover in velvet Ash Pink 2703



▲ SOPHIE SOFA
Struttura in metallo laccato grigio antracite / Rivestimento in Della Brick 046
Anthracite grey lacquered metal structure / Cover in Della Brick 046

Sophie Sofa

Federica Biasi / 2019

Divanetto con imbottitura in poliuretano espanso indeformabile a densità differenziate e fibra poliestere. Rivestimento in tessuto nei colori del campionario. Struttura in metallo laccato ottone satinato oppure grigio antracite.

Small sofa with non-deformable polyurethane foam in different density and polyester fibre. Cover in fabric as per samples. Satin brass or anthracite grey lacquered metal structure.

! Bordo perimetrale nello stesso tessuto del divanetto. In caso di rivestimento in velluto il bordo perimetrale sarà realizzato in gros grain coordinandolo con il tessuto scelto per il rivestimento.

! Perimeter trim in the same fabric of the sofa. In case of velvet cover the perimeter trim will be in gros grain matching it with the fabric chosen for the piece.



Cm
170 x 95 x 70

Inches
67" x 37½" x 27¾"

For technical drawing / p. 221

Pricelist 2023 / p. 114
Homescapes, sense of materials / p. 19
Homescapes, gentle attitude / pp. 86, 87

STRUTTURA/STRUCTURE



Metallo laccato
ottone satinato
Satin brass
lacquered metal



Metallo laccato
grigio antracite
Anthracite grey
lacquered metal

RIVESTIMENTO/COVER



Tessuto nei colori del
campionario
Fabric as per samples.



▲ **STAMI LOUNGE**
Struttura in frassino tinto nero poro aperto / Rivestimento in Fard silt 2324
Black open pore stained ash base / Cover in Fard silt 2324

Stami Lounge

Studiopepe / 2023

Poltrona con base in frassino curvato tinto nero poro aperto e dettagli in ottone lucido. Imbottita in poliuretano espanso rivestito in tessuto o pelle nei colori del campionario. Fornita di un cuscino diam. cm 38 in piuma rivestito nello stesso rivestimento.

! Rivestimento sfoderabile.

Armchair with curved black open pore stained ash base and bright brass details. Padding in polyurethane foam covered by fabric or leather as per samples. A diam. 38 cm downpadding cushion covered in the same finish of the armchair included.

! Removable cover.



Cm
76 x 67,5 x 69,5

Cuscino
Ø38

Inches
30" x 26¾" x 27½"

Cushion
Ø15"

[For technical drawing / p.222](#)

[Pricelist 2023 / p.115](#)

BASE/BASE

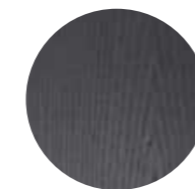

Frassino tinto nero poro aperto
Black open pore stained ash

DETTAGLI/DETAILS

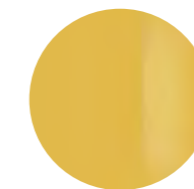

Ottone lucido
Bright brass

RIVESTIMENTO/COVER



Tessuto/pelle nei colori del campionario
Fabric/leather as per samples.

05

Divani e Poltrone / Sofas and Armchairs
TECHNICAL MODULE

0417 | Studio G&R, 2017

Product information / p.152

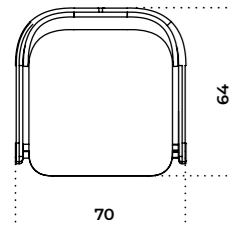
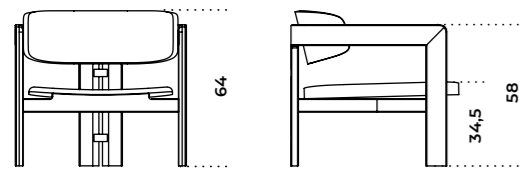

Akiko Lounge | Oscar e Gabriele Buratti, 2022

Product information / p.154

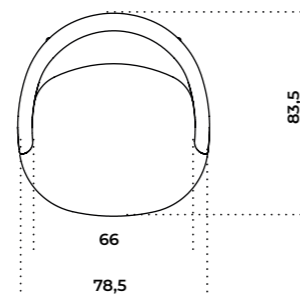
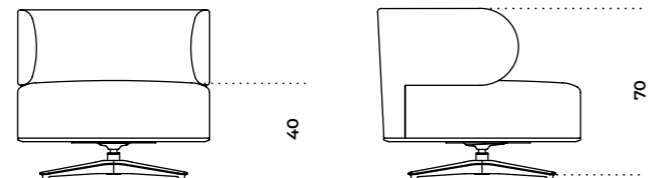
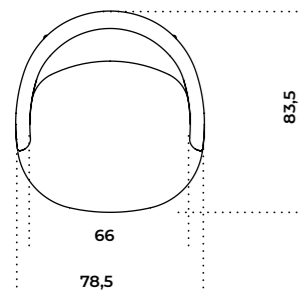
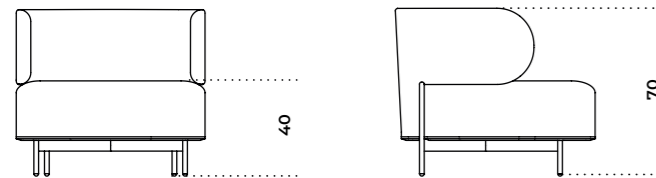

Versione girevole
Swivel version

Audrey | Massimo Castagna, 2017

Product information / p.156

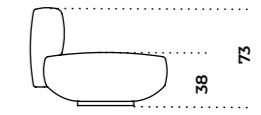
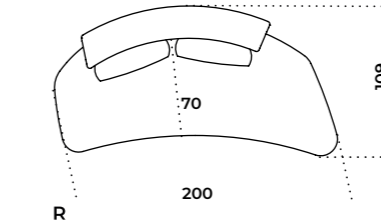
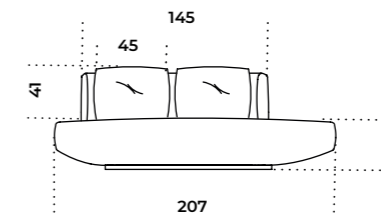
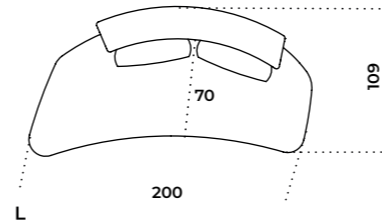
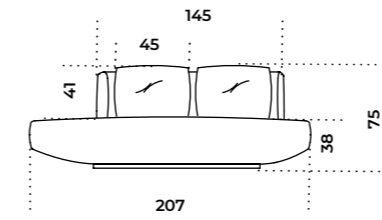

Cuscino decorativo
Decorative cushion
40 x 40
15¾" x 15¾"
60 x 60
23¾" x 23¾"

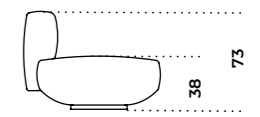
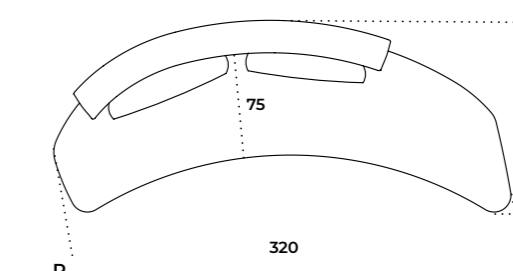
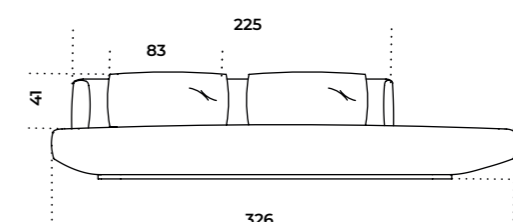
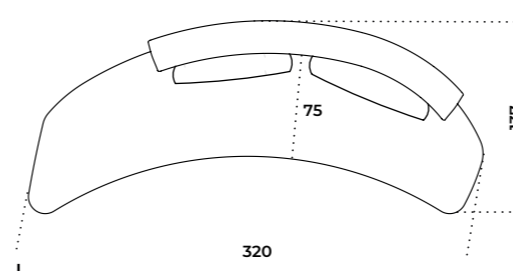
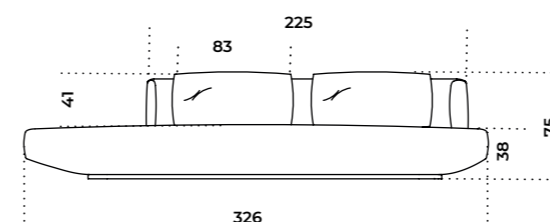
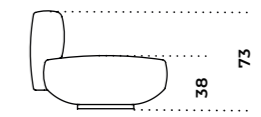
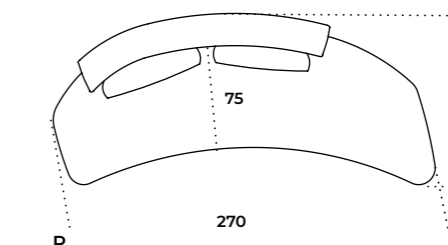
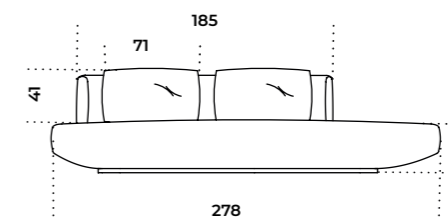
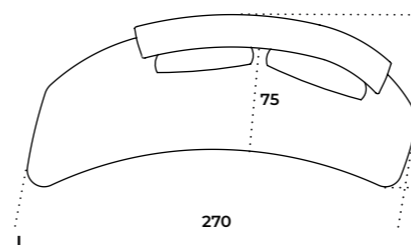
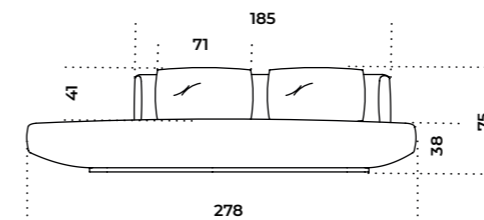
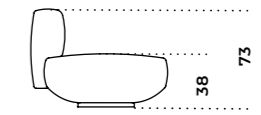
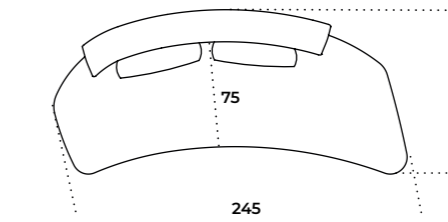
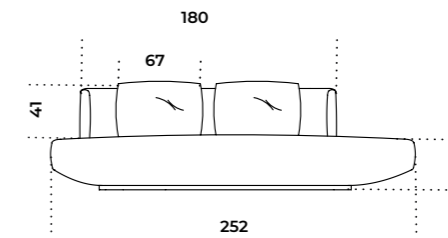
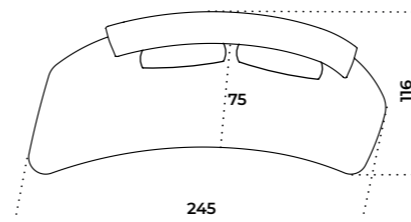
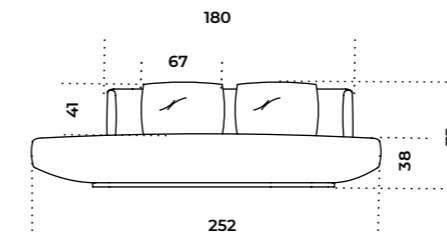

Audrey Motion | Massimo Castagna, 2020

Product information / p. 158

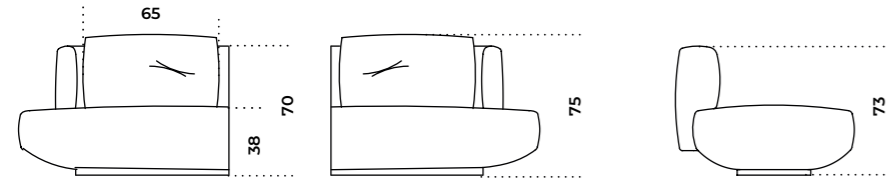

Cuscino decorativo
Decorative cushion
40 x 40
15¾" x 15¾"
60 x 60
23¾" x 23¾"

Moduli
Modules

T115L / T115R

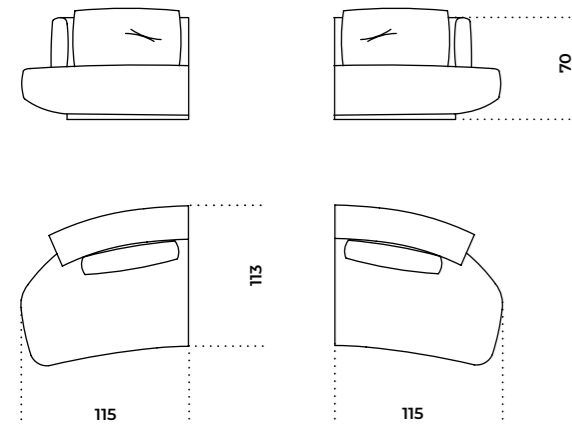

T160L / T160R

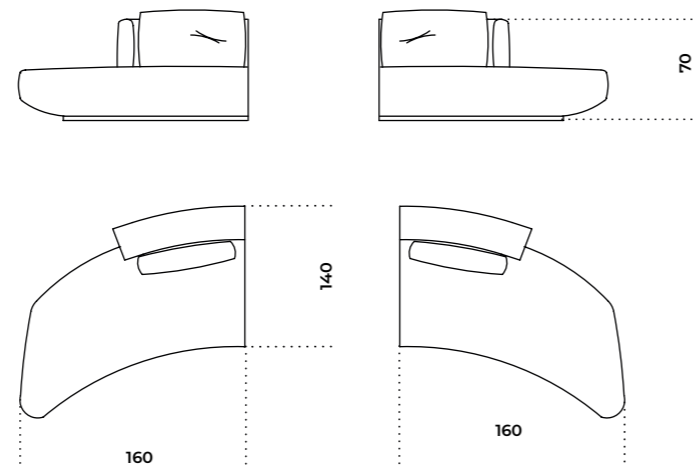

C175

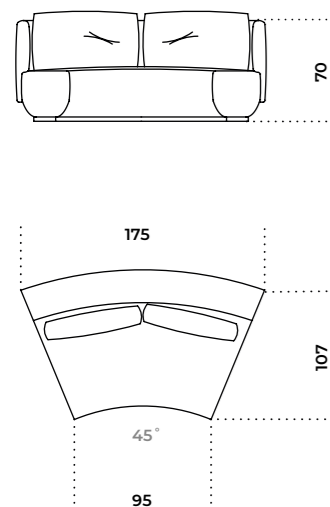

C200

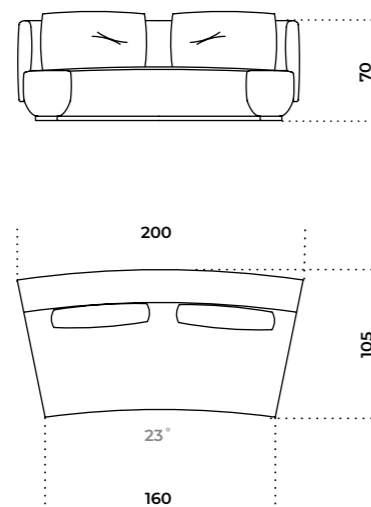

C235

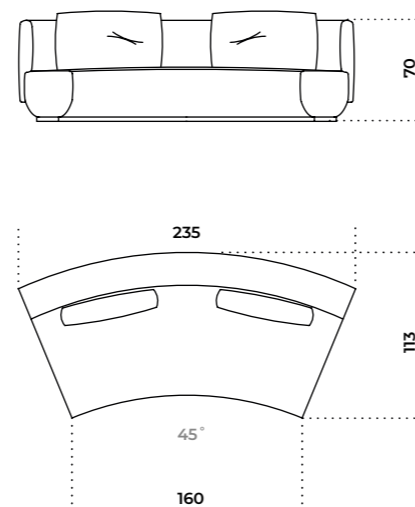

Composizioni
Compositions

Composizione 1 / Composition 1

431 x 190 x 73h
169½" x 75" x 28¾"h

Composta da
Composed by
n.1 T160L
n.1 C235
n.1 T115R

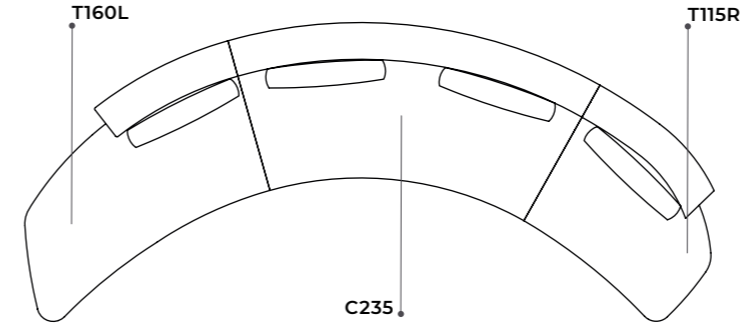

Set cuscini decorativi consigliati (non inclusi):
Recommended decorative pillow sets (not included)
n.4 cm 60x60 | 23¾" x 23¾"
n.3 cm 40x40 | 15¾" x 15¾"

Composizione 2 / Composition 2

437 x 245 x 73h
172¼" x 96½" x 28¾"h

Composta da
Composed by
n.1 T160L
n.2 C175
n.1 T115R

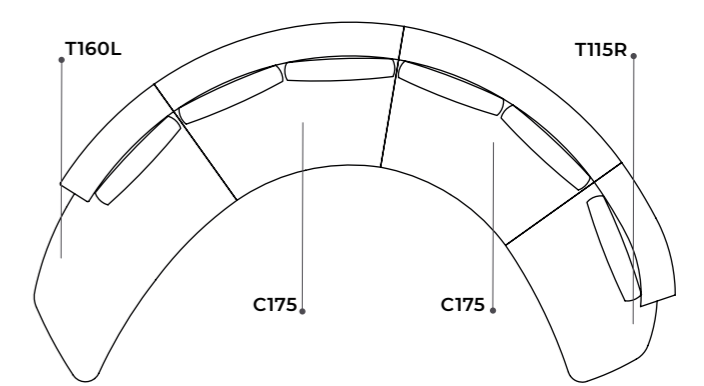

Set cuscini decorativi consigliati (non inclusi):
Recommended decorative pillow sets (not included)
n.4 cm 60x60 | 23¾" x 23¾"
n.4 cm 40x40 | 15¾" x 15¾"

Composizione 3 / Composition 3

507 x 236 x 73h
199¾" x 93" x 28¾"h

Composta da
Composed by
n.1 T160L
n.1 C175
n.1 C200
n.1 T115R

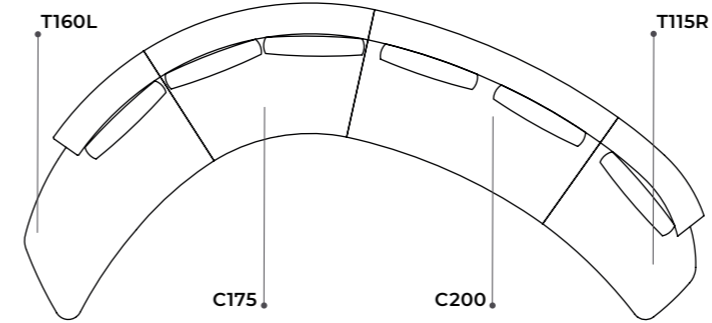

Set cuscini decorativi consigliati (non inclusi):
Recommended decorative pillow sets (not included)
n.5 cm 60x60 | 23¾" x 23¾"
n.4 cm 40x40 | 15¾" x 15¾"

Composizione 4 / Composition 4

575 x 236 x 73h
226½" x 93" x 28¾"h

Composta da
Composed by
n.1 T160L
n.1 C200
n.1 C235
n.1 T115R

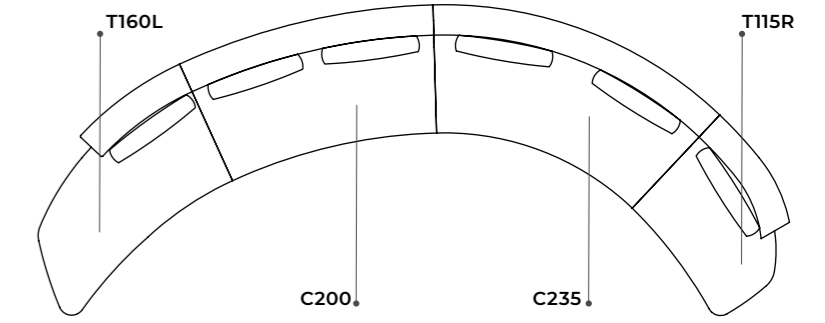

Set cuscini decorativi consigliati (non inclusi):
Recommended decorative pillow sets (not included)
n.5 cm 60x60 | 23¾" x 23¾"
n.4 cm 40x40 | 15¾" x 15¾"

Composizione 5 / Composition 5

676 x 177 x 73h
266¼" x 69¾" x 28¾"h

Composta da
Composed by
n.2 T160L
n.2 C235

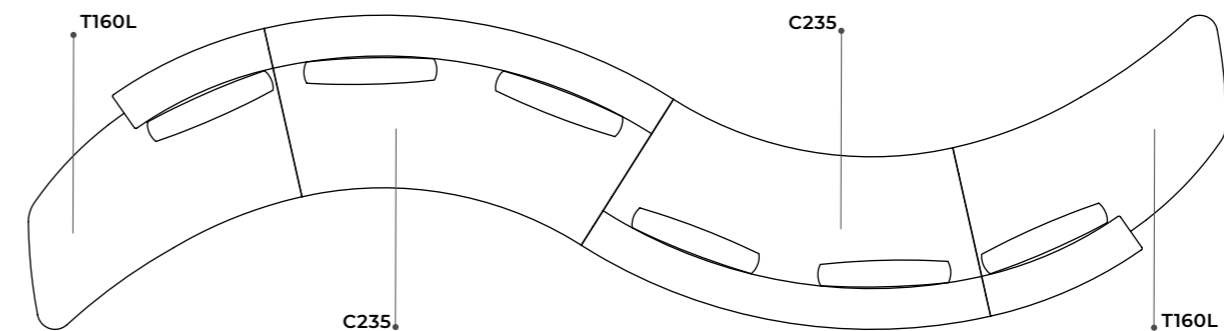

Set cuscini decorativi consigliati (non inclusi):
Recommended decorative pillow sets (not included)
n.6 cm 60x60 | 23¾" x 23¾"
n.4 cm 40x40 | 15¾" x 15¾"

Audrey Poltrona | Massimo Castagna, 2018

Product information / p. 160

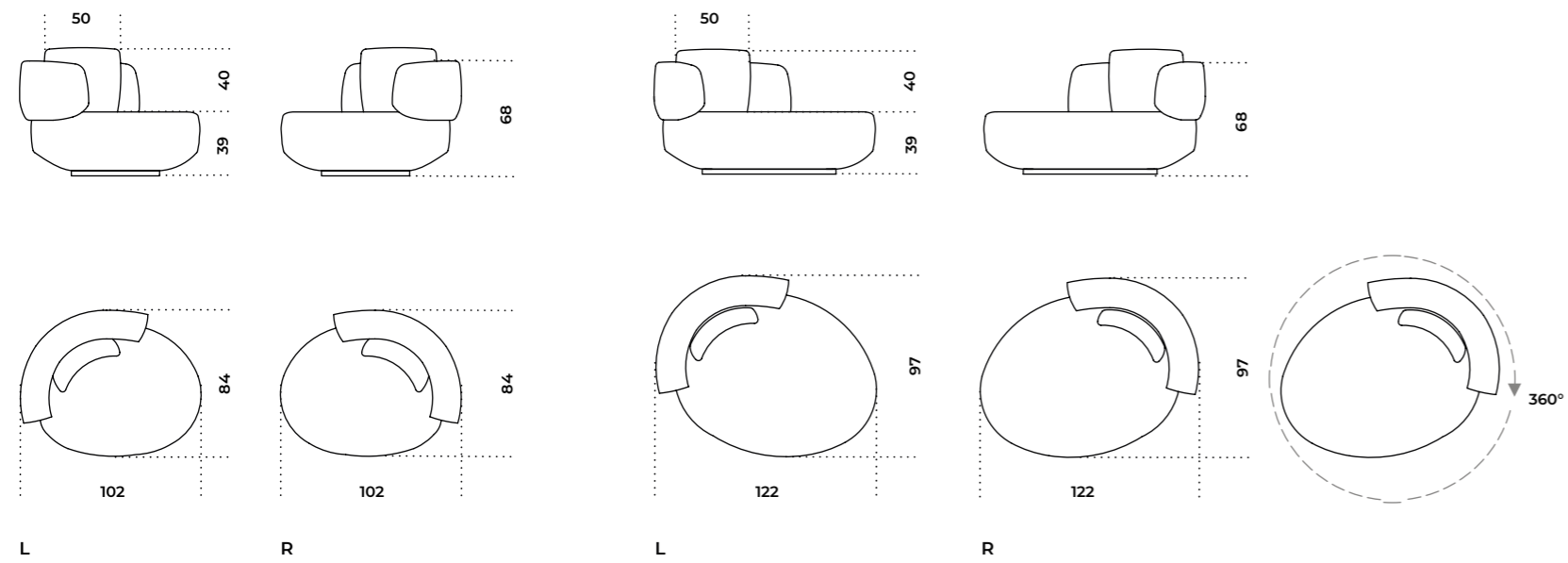

Cloud Infinity | Massimo Castagna, 2022

Product information / p. 164

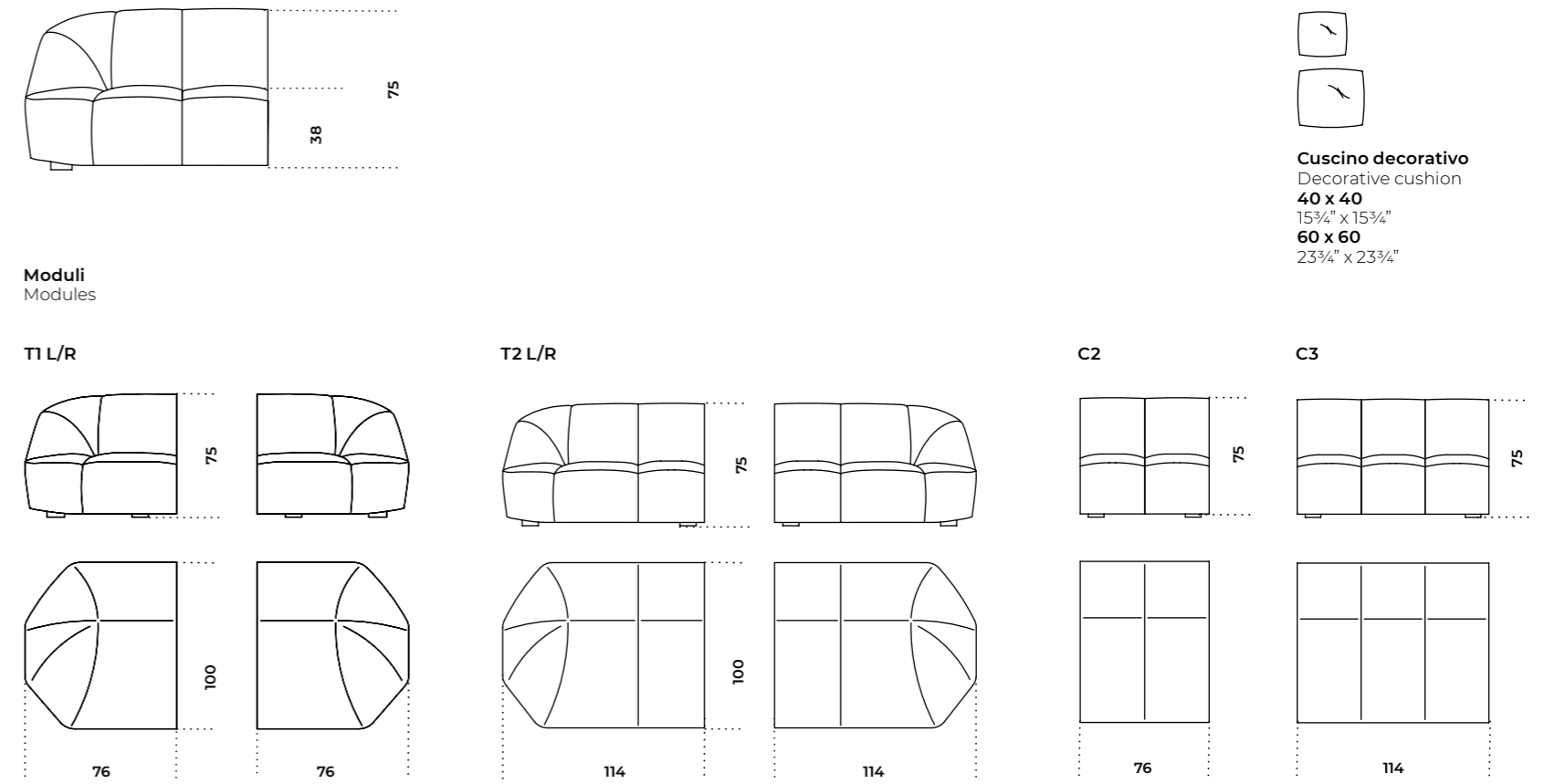

Cloud | Massimo Castagna, 2016

Product information / p. 162

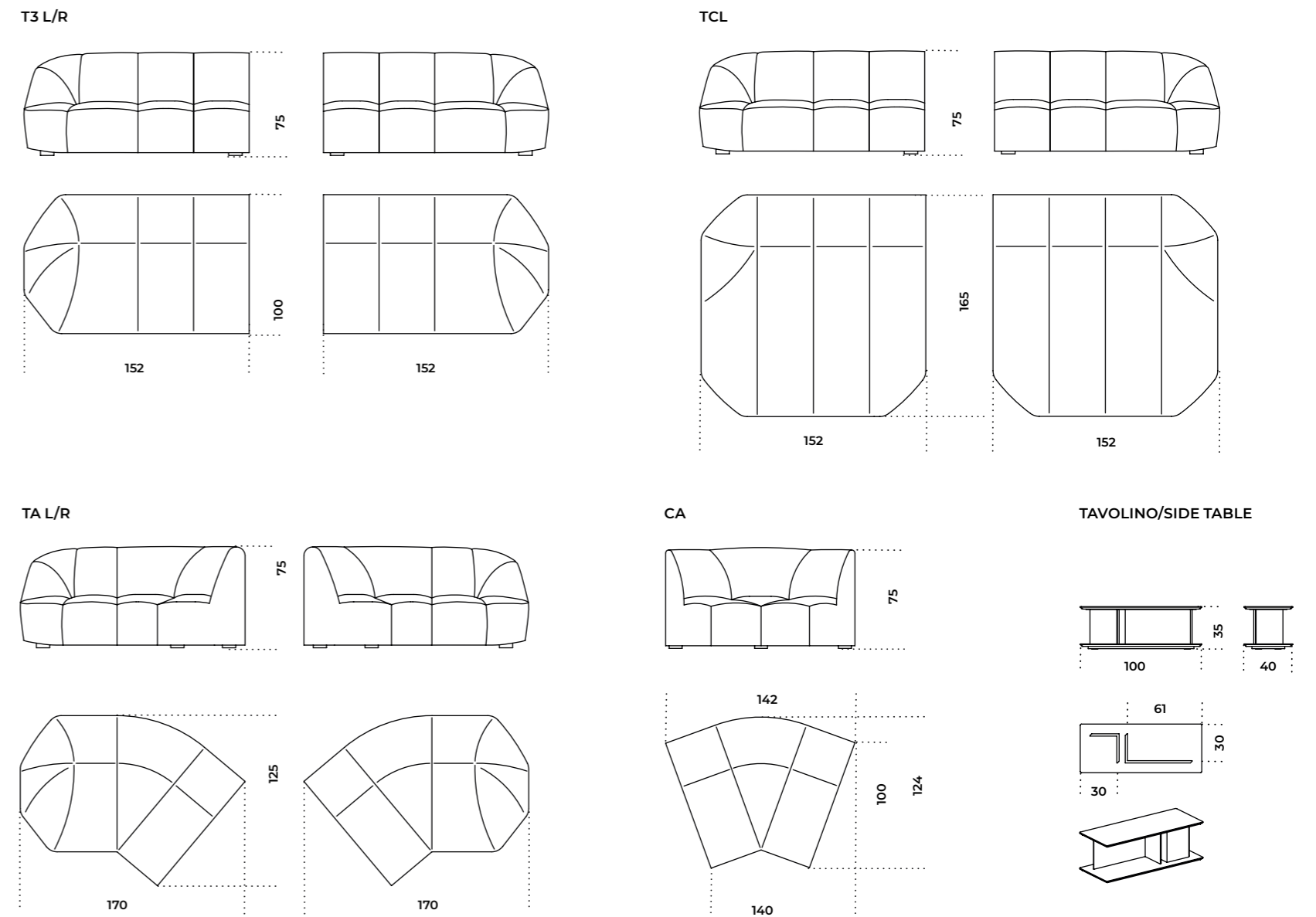
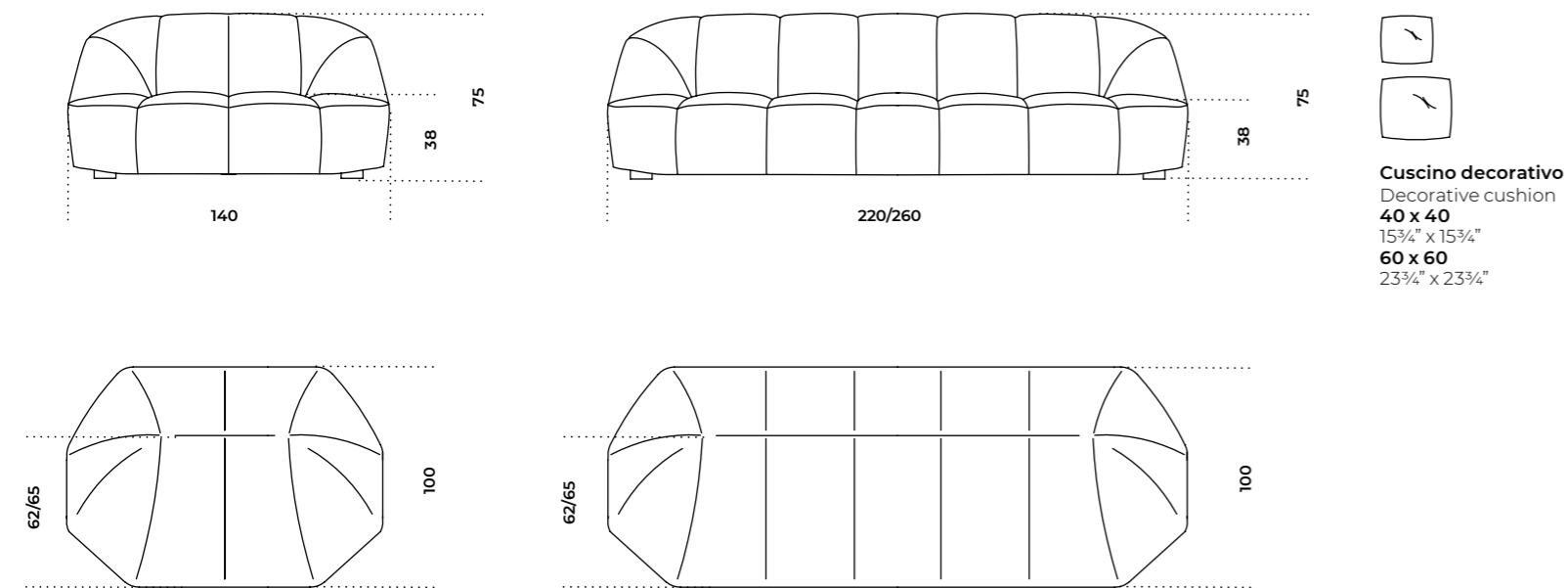

Composizioni
Compositions

Composizione 1 / Composition 1

276 x 131 x 75h
108¾" x 51¾" x 29¾"h

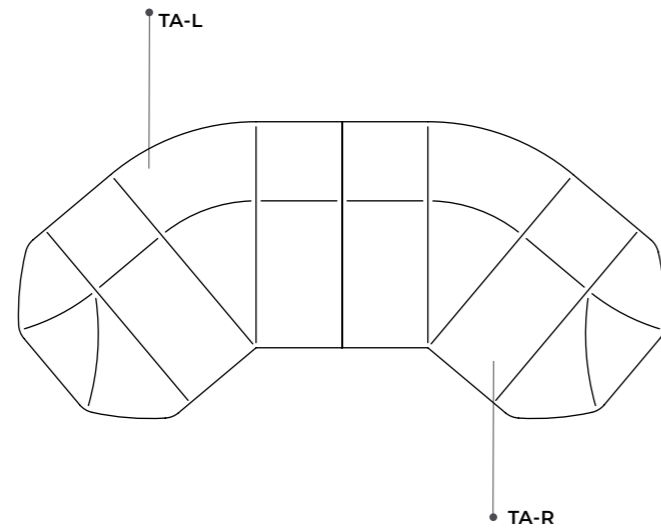

Product information / p.164

Composta da
Composed by
n.1 TA-L
n.1 TA-R

Composizioni
Compositions

Composizione 3 / Composition 3

600 x 215 x 75h
236¾" x 84¾" x 29¾"h

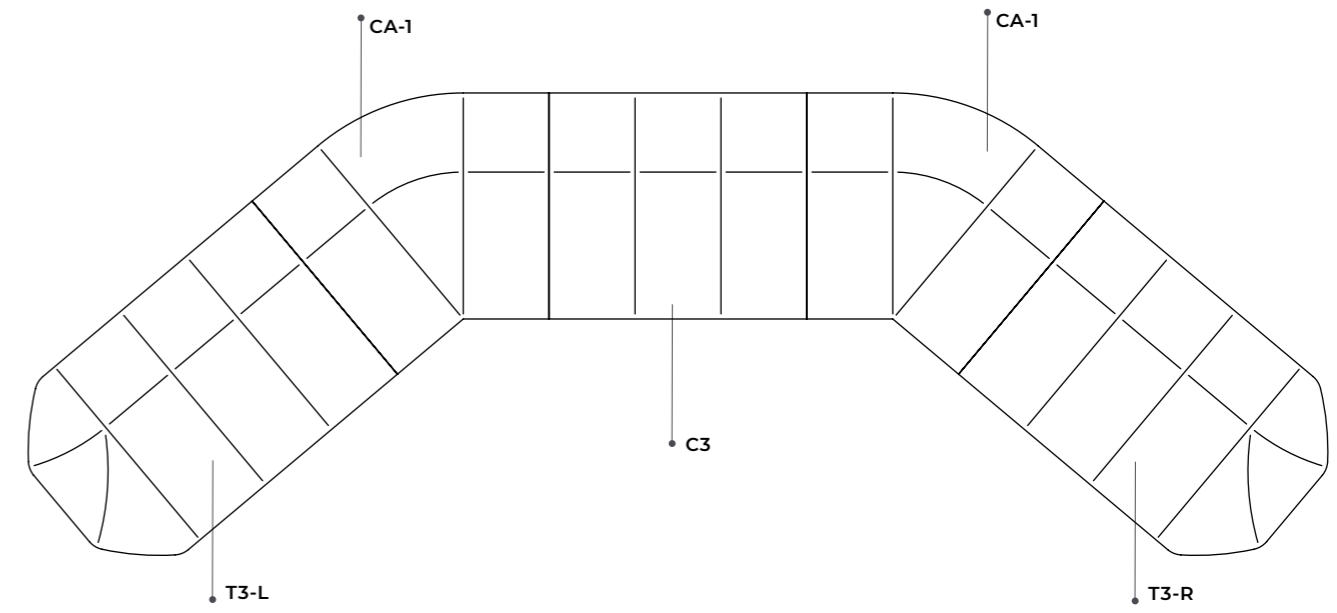

Product information / p.164

Composta da
Composed by
n.1 T3-L
n.1 CA-1
n.1 C-3
n.1 CA-1
n.1 T3-R

Composizione 2 / Composition 2

396 x 131 x 75h
156" x 51¾" x 29¾"h

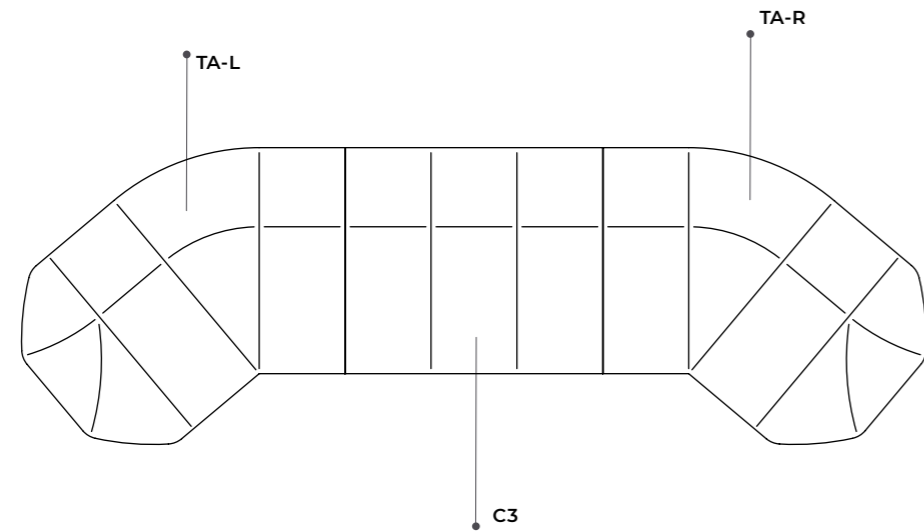

Composta da
Composed by
n.1 TA-L
n.1 C-3
n.1 TA-R

Composizione 4 / Composition 4

436,5 x 232,5 x 75h
172" x 91¾" x 29¾"h

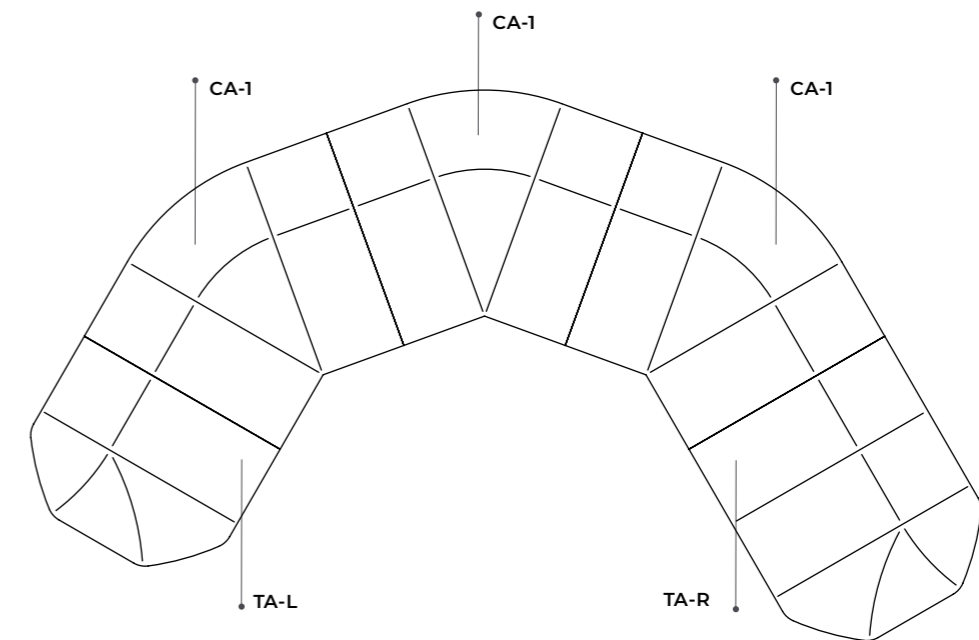

Composta da
Composed by
n.1 T1-L
n.3 CA-1
n.1 T2-R

Composizioni
Compositions

Product information / p.164

Composizione 5 / Composition 5

420 x 165 x 75h
165½" x 65" x 29¾"h

Composta da
Composed by
n.1 T3-L
n.1 C2
n.1 TCL-R
n.1 side table

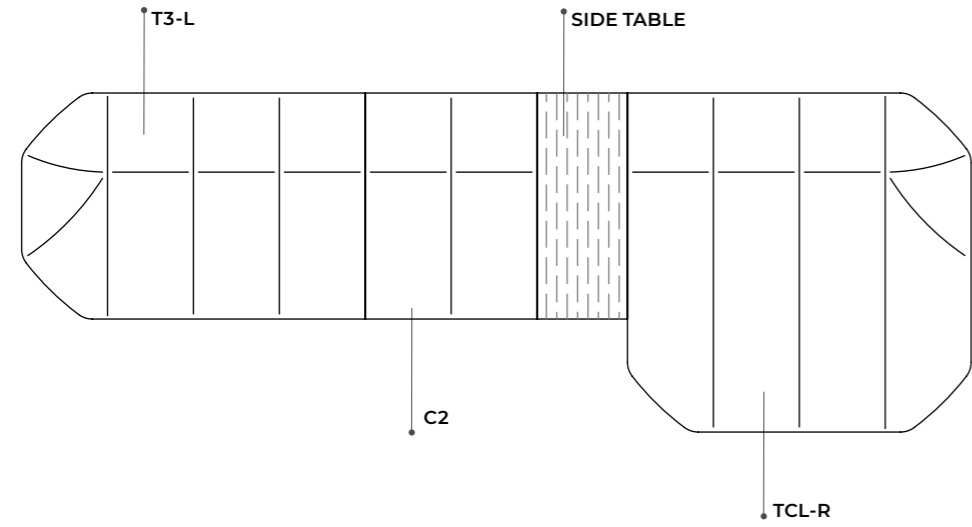

Composizioni
Compositions

Product information / p.164

Composizione 7 / Composition 7

520 x 305 x 75h
204¾" x 120¼" x 29¾"h

Composta da
Composed by
n.1 T1-L
n.1 C3
n.1 CA
n.1 C2
n.1 TCL-R
n.1 side table

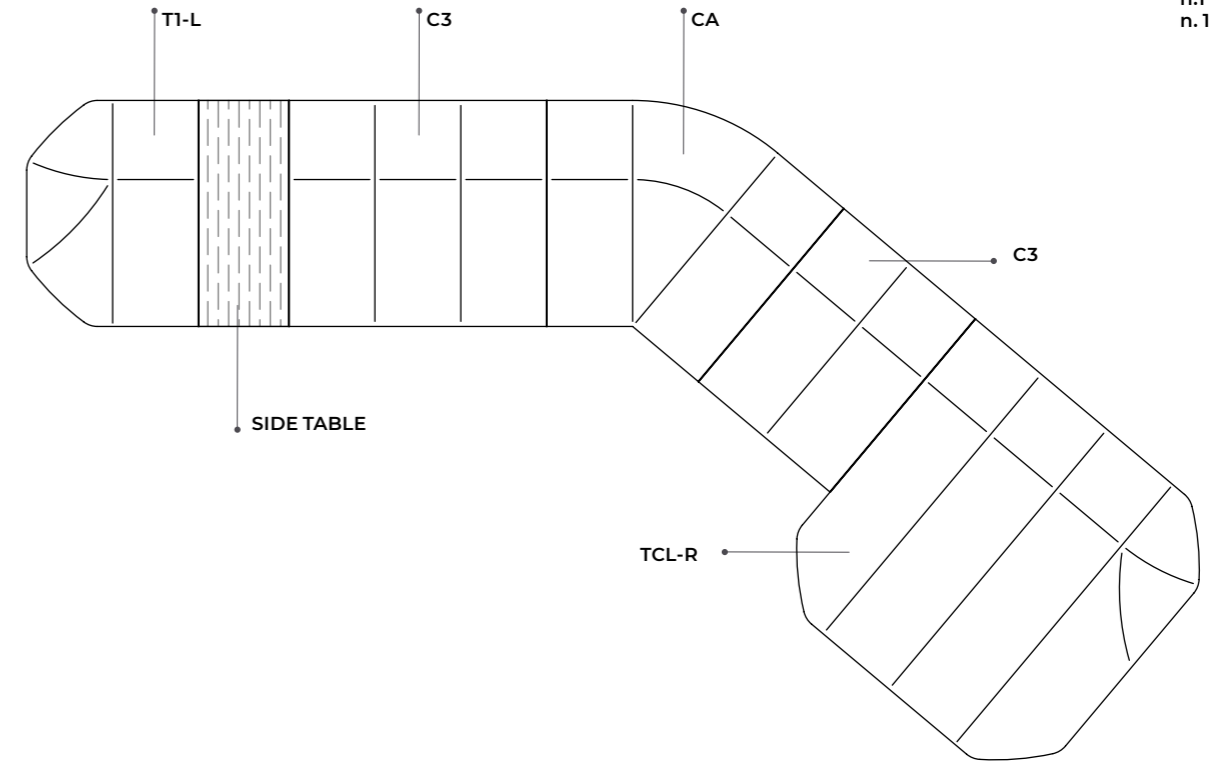

Composizione 6 / Composition 6

635 x 280 x 75h
250¼" x 110¼" x 29¾"h

Composta da
Composed by
n.1 T2-L
n.1 C2
n.2 CA
n.1 C3
n.1 TCL-R
n.1 side table

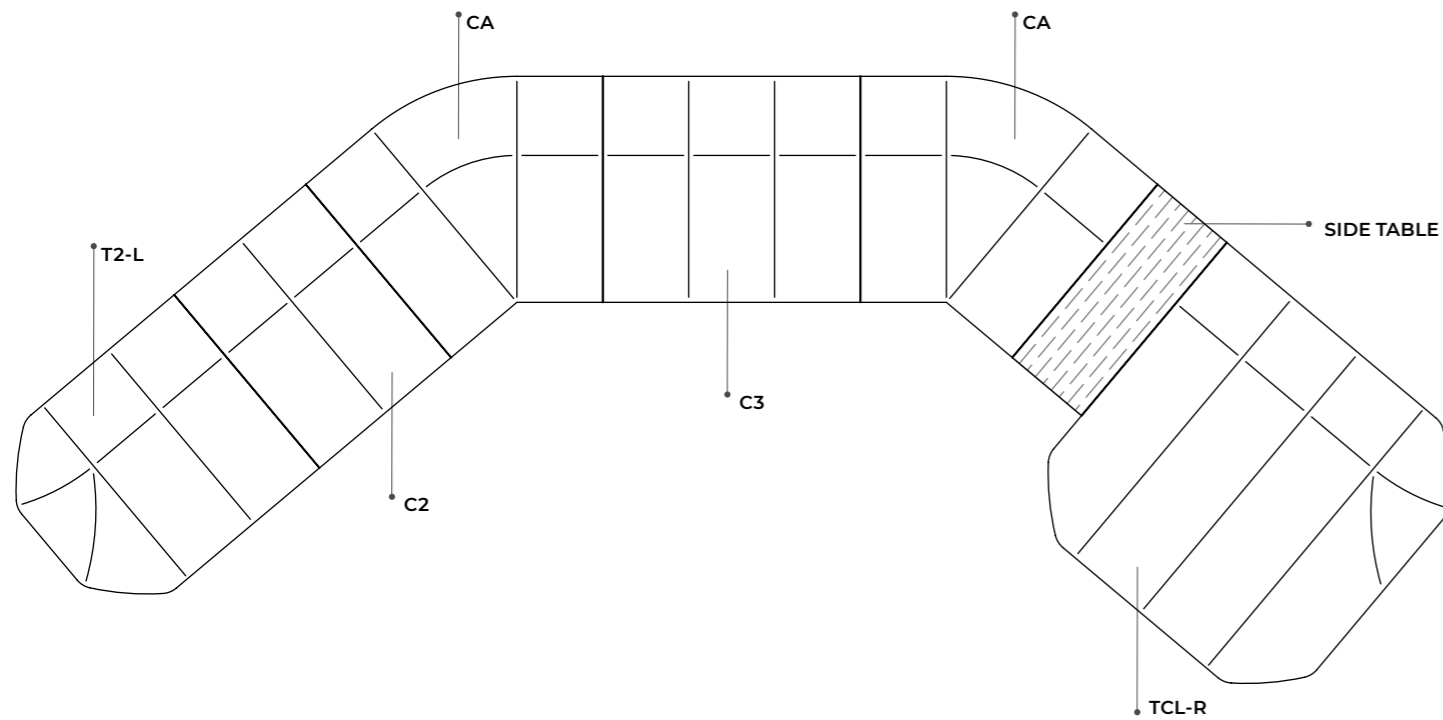

Composizione 8 / Composition 8

523 x 370 x 75h
206" x 145¾" x 29¾"h

Composta da
Composed by
n.1 T3-L
n.4 CA
n.1 T3-R
n. 3 small table

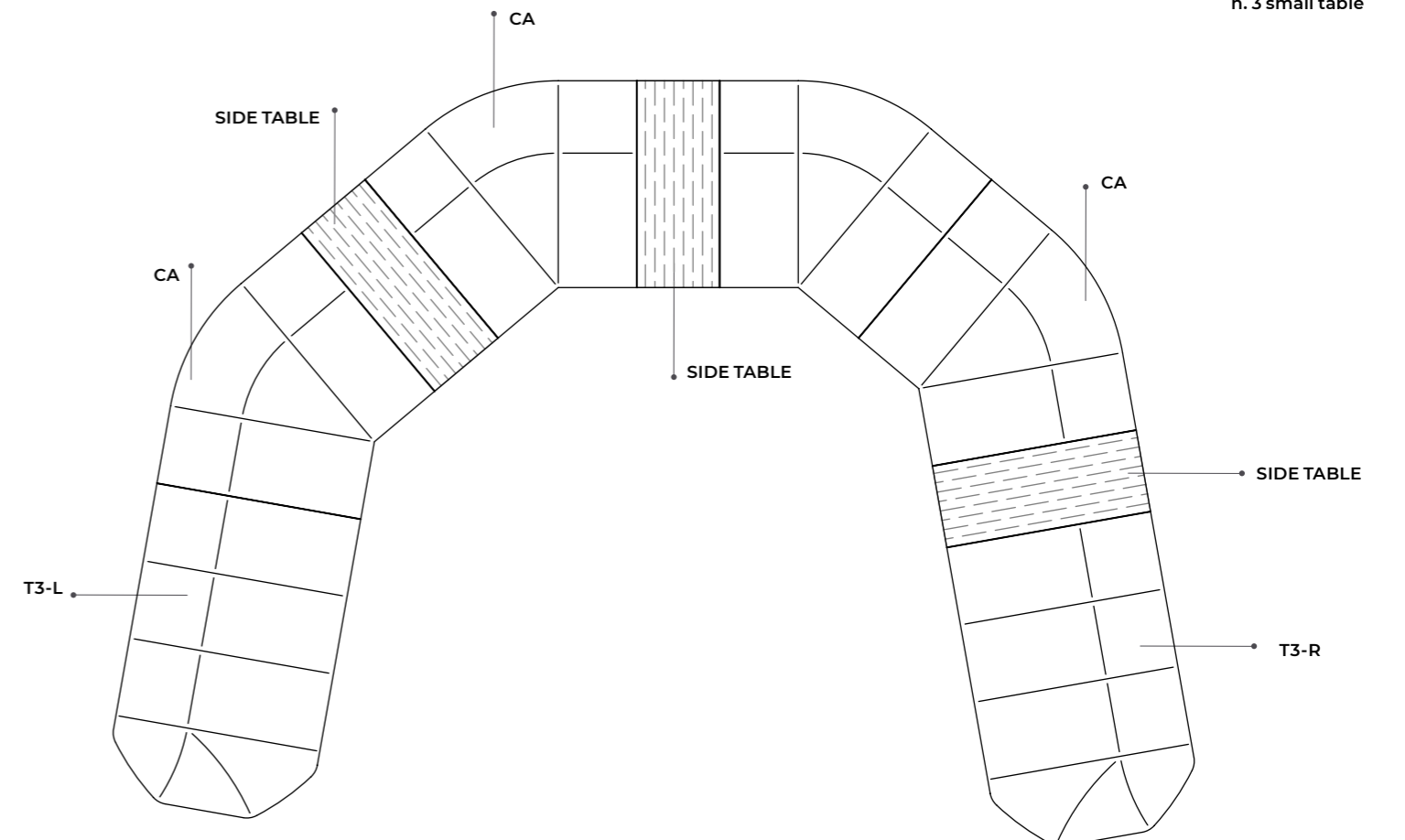

Cloud Poltrona | Massimo Castagna, 2016

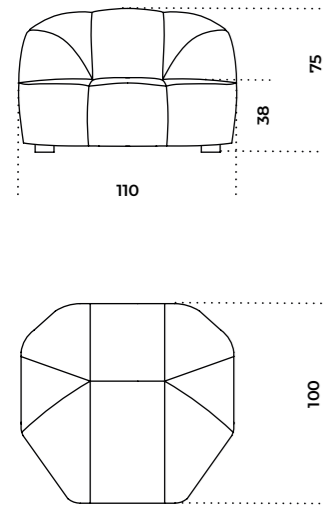

Product information / p. 166

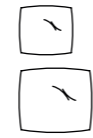

Cuscino decorativo
Decorative cushion
40 x 40
15¾" x 15¾"
60 x 60
23¾" x 23¾"

Elissa Sectional | Dainelli Studio, 2021

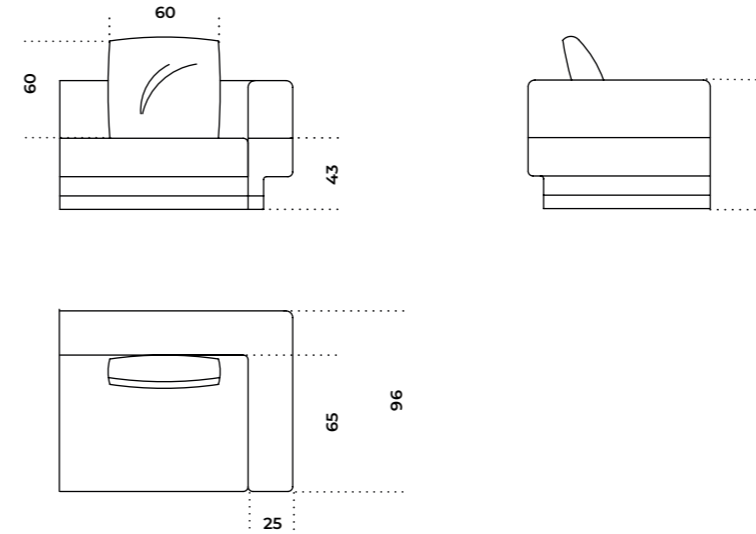

Product information / p. 170

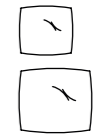

Cuscino decorativo
Decorative cushion
40 x 40
15¾" x 15¾"
60 x 60
23¾" x 23¾"

Elissa | Dainelli Studio, 2020

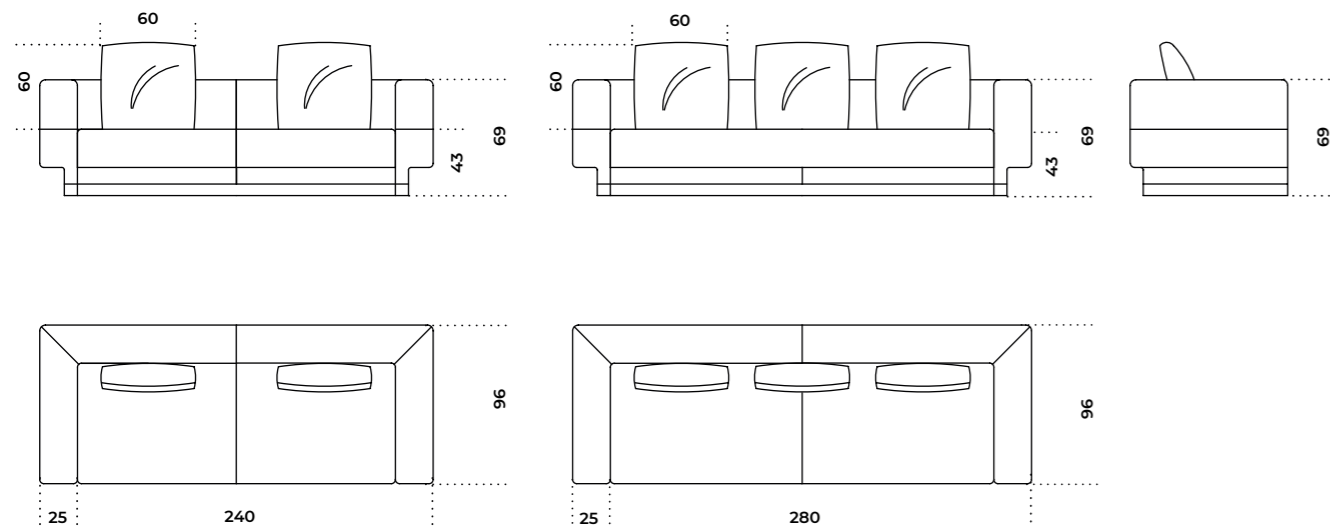

Product information / p. 168

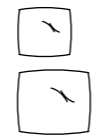

Cuscino decorativo
Decorative cushion
40 x 40
15¾" x 15¾"
60 x 60
23¾" x 23¾"

Moduli
Modules

ELS-T120L/T120R

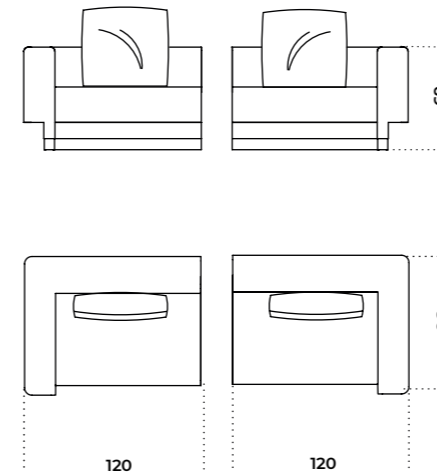

ELS-T140L/T140R

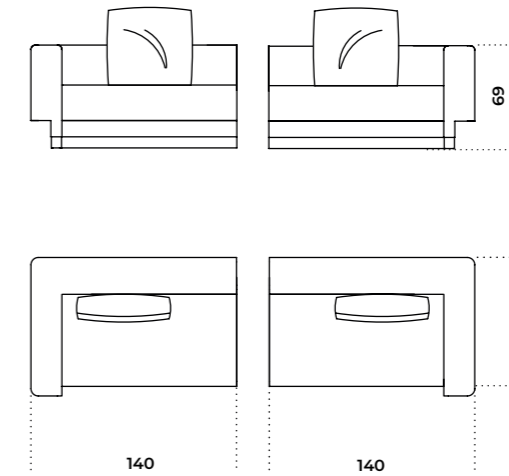

ELS-A140L/A140R

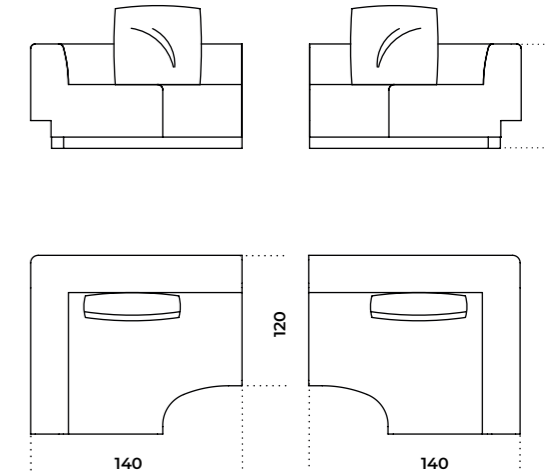

ELS-T220L/T220R

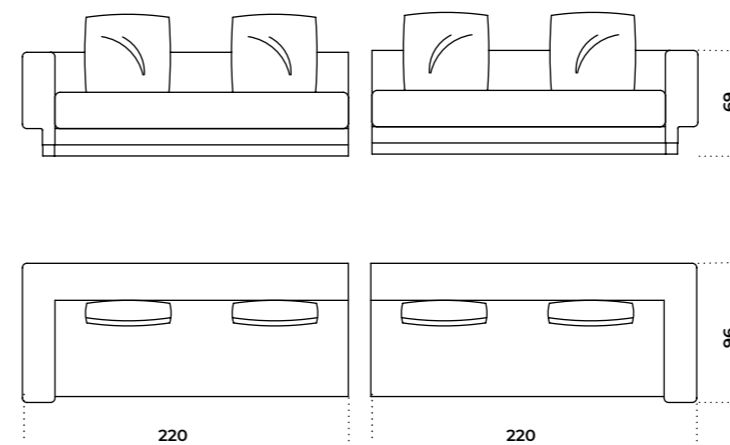

ELS-T260L/T260R

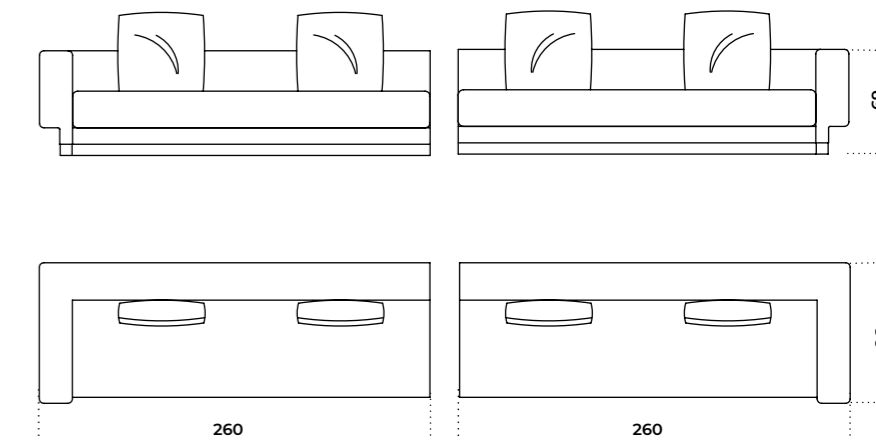

Moduli
Modules

Product information / p. 170

ELS-TA225L/TA225R

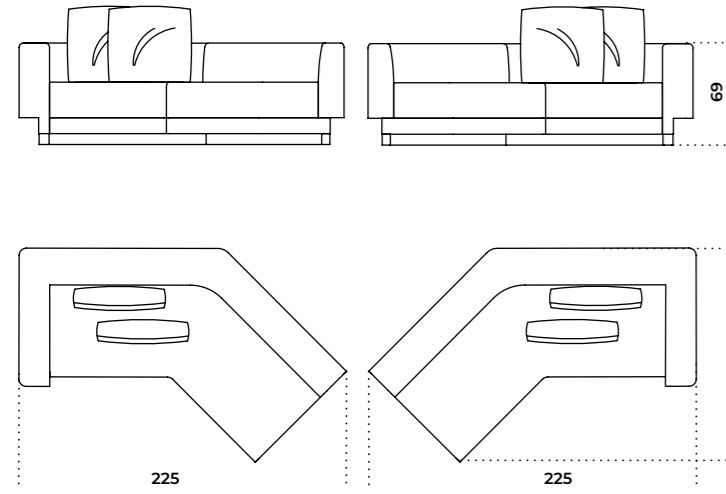

ELS-TA240L/TA240R

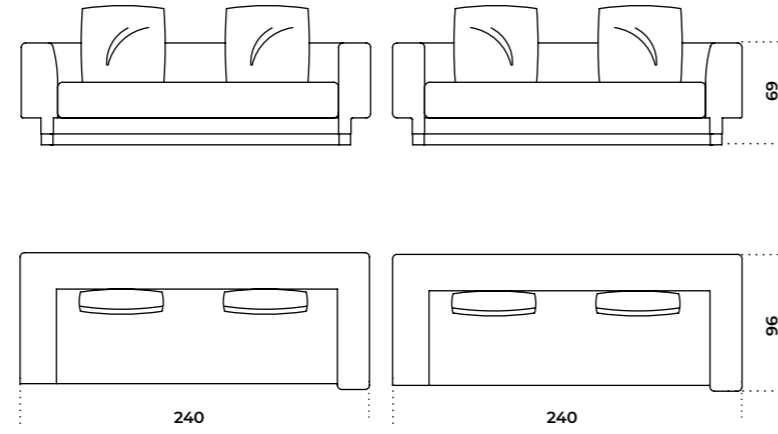

ELS-CA200

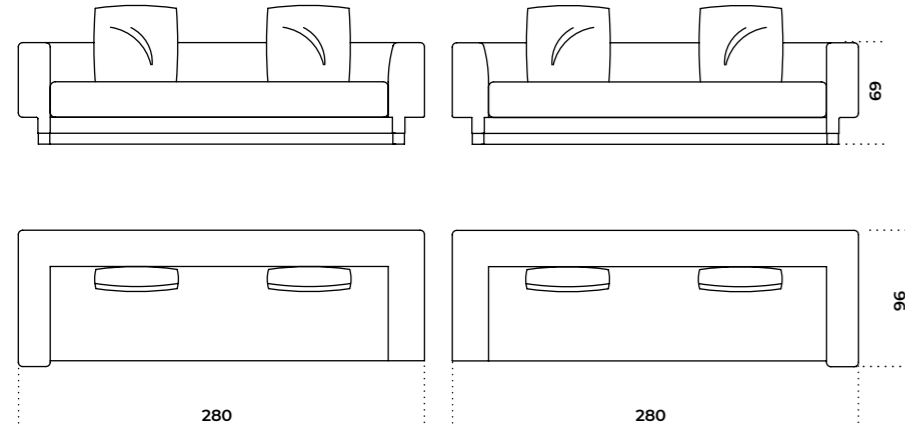

ELS-CA200

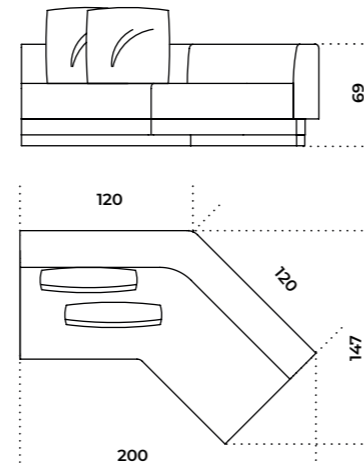

ELS-C100

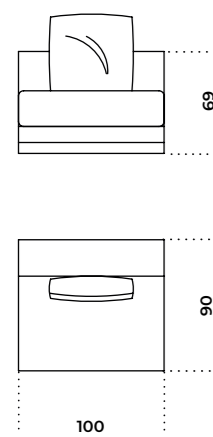

ELS-C120

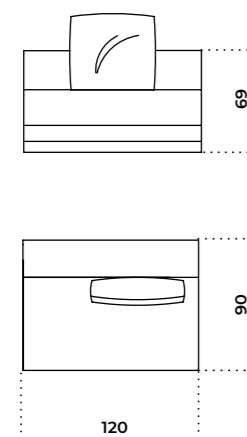

ELS-C200

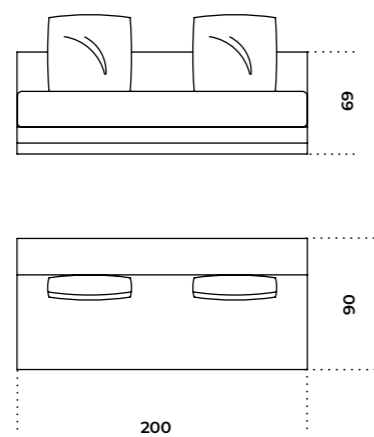

ELS-C240

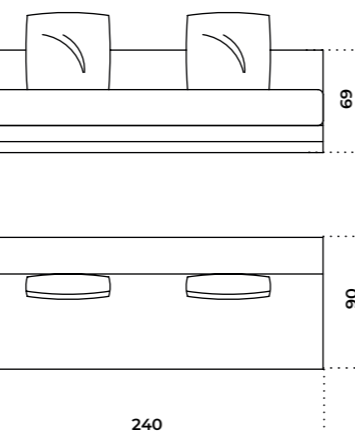

Composizioni
Compositions

Product information / p. 170

Composizione 1 / Composition 1

400 x 96 x 69h
157½" x 38" x 27¼"h

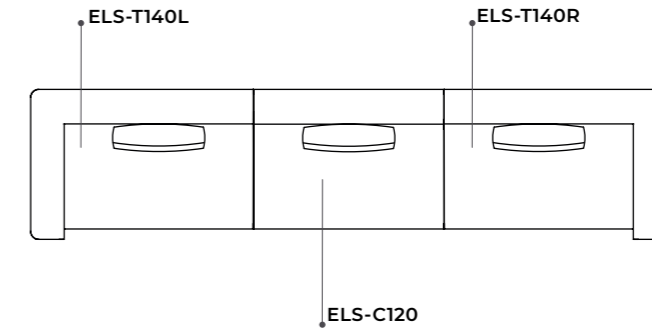

Composta da
Composed by
n.1 ELS-T140L
n.1 ELS-C120
n.1 ELS-T140R

Composizione 2 / Composition 2

280 x 260 x 69h
110¼" x 102½" x 27¼"h

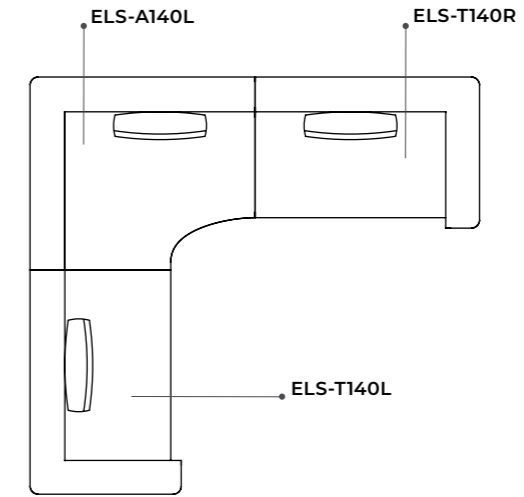

Composta da
Composed by
n.1 ELS-T140L
n.1 ELS-A140L
n.1 ELS-T140R

Composizione 3 / Composition 3

360 x 280 x 69h
141¾" x 110¼" x 27¼"h

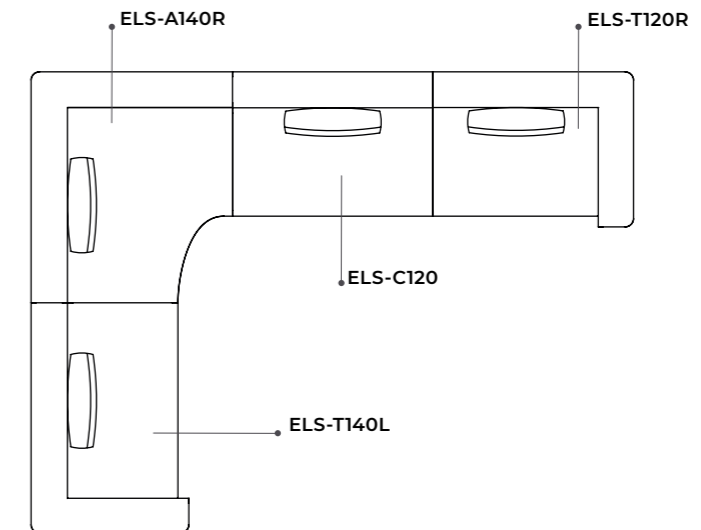

Composta da
Composed by
n.1 ELS-T140L
n.1 ELS-A140R
n.1 ELS-C120
n.1 ELS-T120R

Composizioni
Compositions

[Product information / p. 170](#)

Composizione 4 / Composition 4

356 x 164 x 69h
140³/₄" x 64³/₄" x 27¹/₄"h

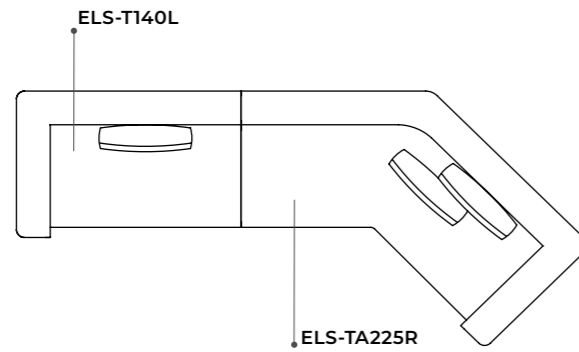

Composta da
Composed by
n.1 ELS-T140L
n.1 ELS-TA225R

Composizioni
Compositions

[Product information / p. 170](#)

Composizione 7 / Composition 7

230 x 280 x 69h
90³/₄" x 110¹/₄" x 27¹/₄"h

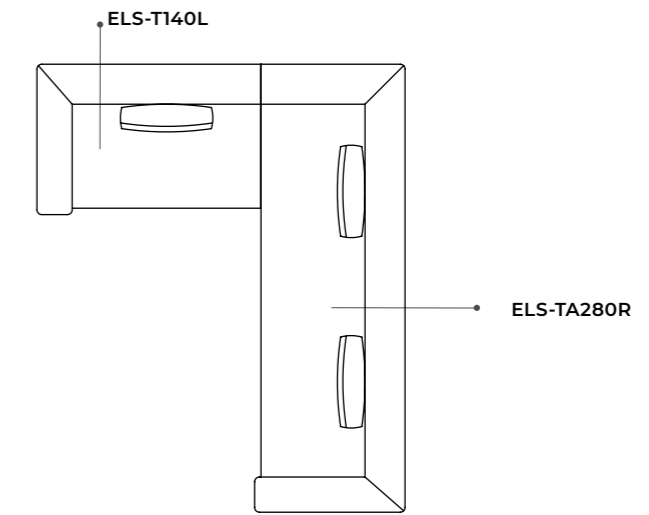

Composta da
Composed by
n.1 ELS-T140L
n.1 ELS-TA280R

Composizione 5 / Composition 5

475 x 185 x 69h
187¹/₂" x 73" x 27¹/₄"h

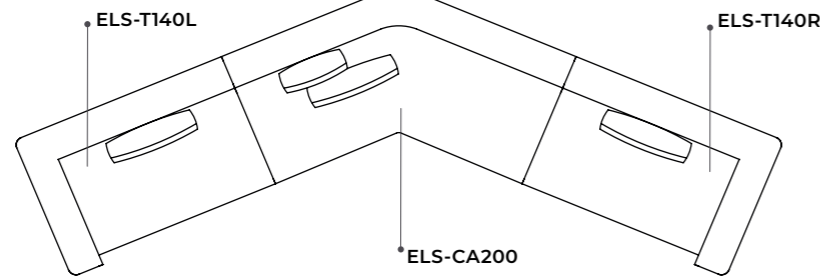

Composta da
Composed by
n.1 ELS-T140L
n.1 ELS-CA200
n.1 ELS-T140R

Composizione 8 / Composition 8

350 x 240 x 69h
138" x 94¹/₂" x 27¹/₄"h

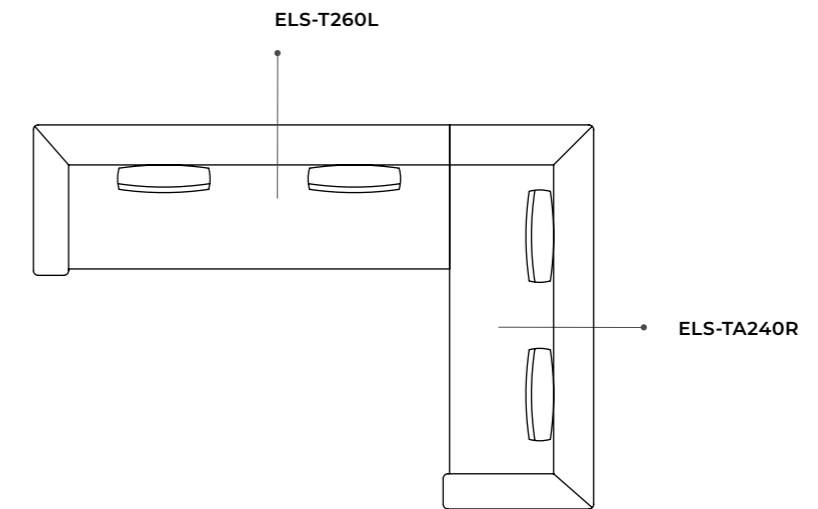

Composta da
Composed by
n.1 ELS-T260L
n.1 ELS-TA240R

Composizione 6 / Composition 6

430 x 164 x 69h
169¹/₂" x 64³/₄" x 27¹/₄"h

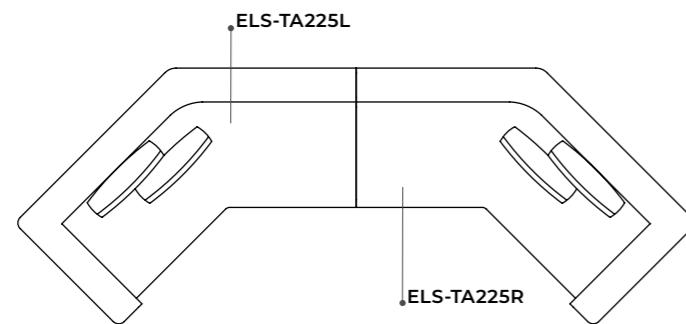

Composta da
Composed by
n.1 ELS-TA225L
n.1 ELS-TA225R

Composizione 9 / Composition 9

420 x 280 x 69h
165¹/₂" x 110¹/₄" x 27¹/₄"h

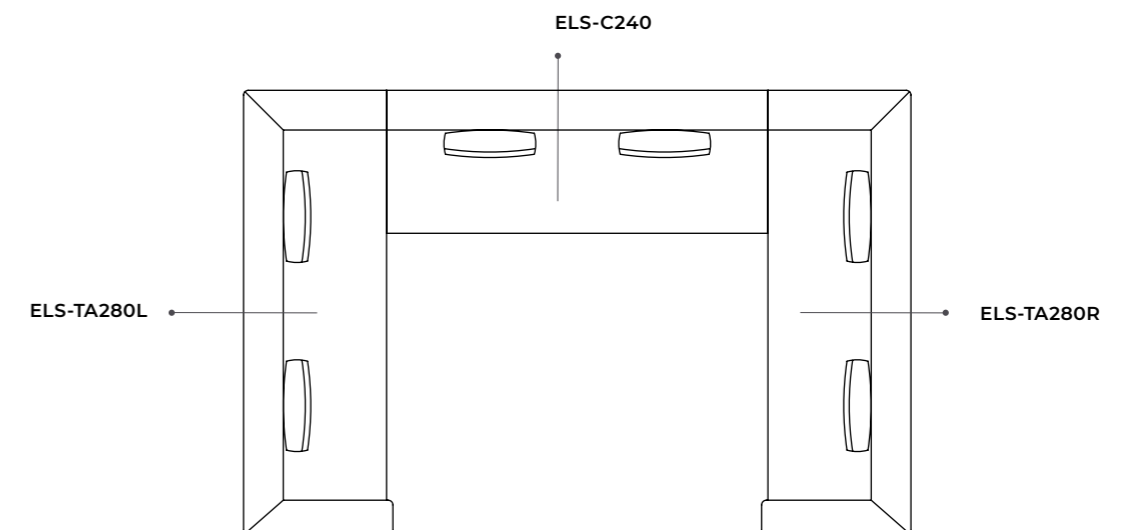

Composta da
Composed by
n.1 ELS-TA280L
n.1 ELS-C240
n.1 ELS-TA280R

Fiona | Massimo Castagna, 2018

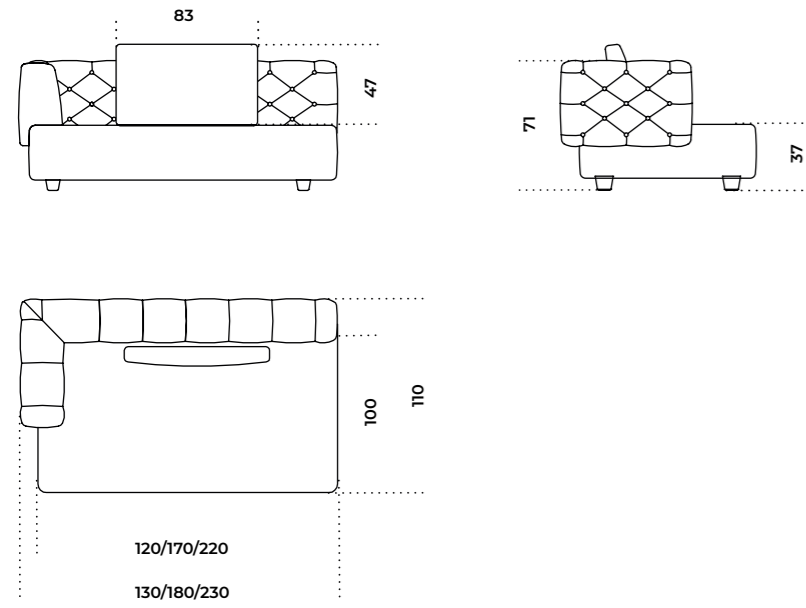

Product information / p. 174



Cuscino decorativo
Decorative cushion
40 x 40
15¾" x 15¾"
60 x 60
23¾" x 23¾"

Fiona Soft | Massimo Castagna, 2019

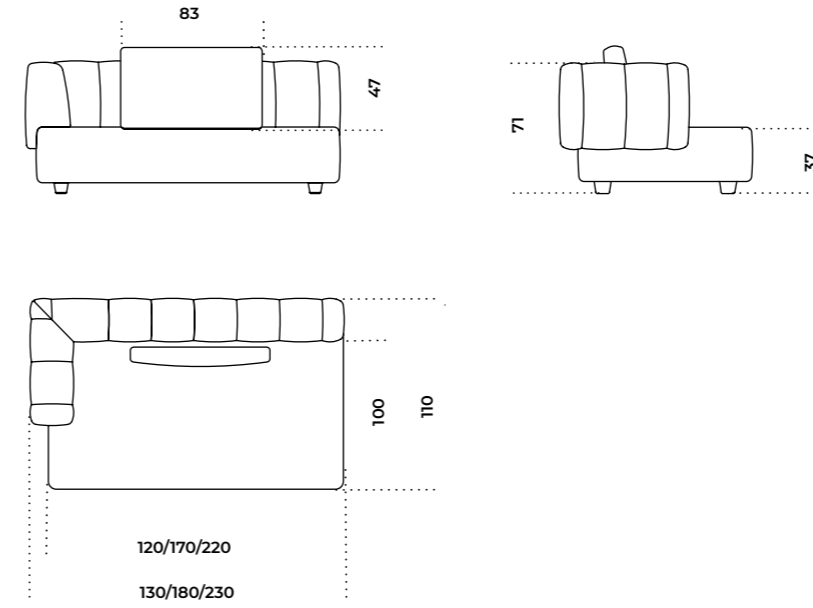

Product information / p. 176

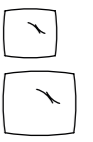

Cuscino decorativo
Decorative cushion
40 x 40
15¾" x 15¾"
60 x 60
23¾" x 23¾"

Moduli
Modules

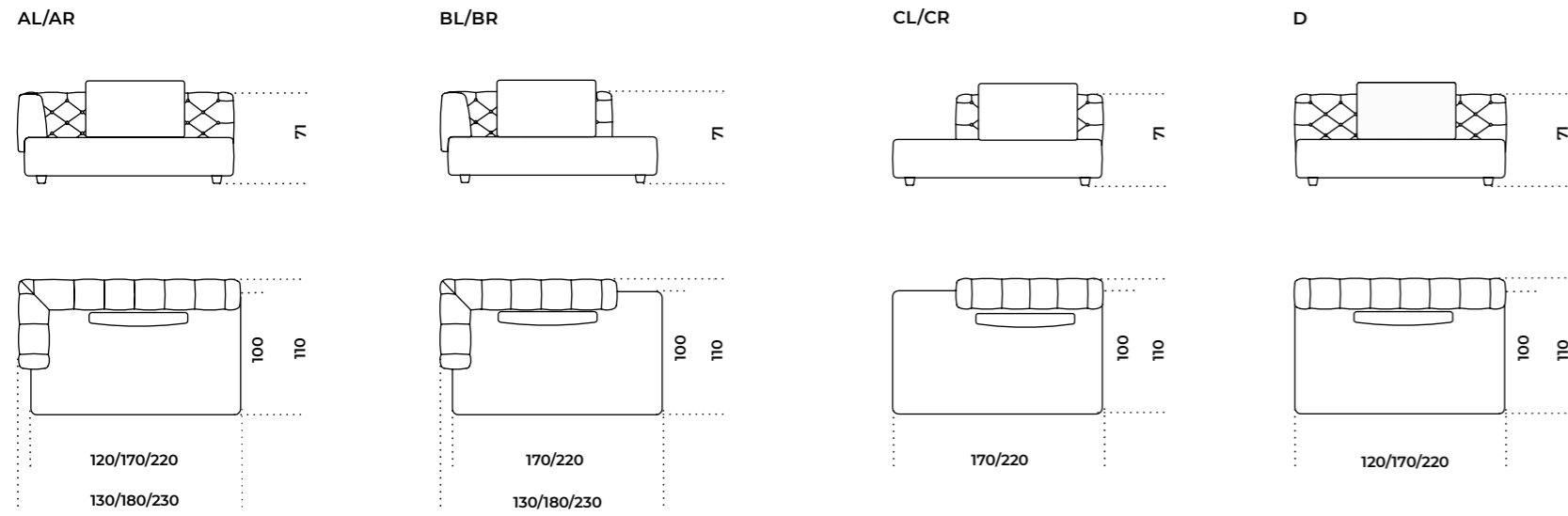

Moduli
Modules

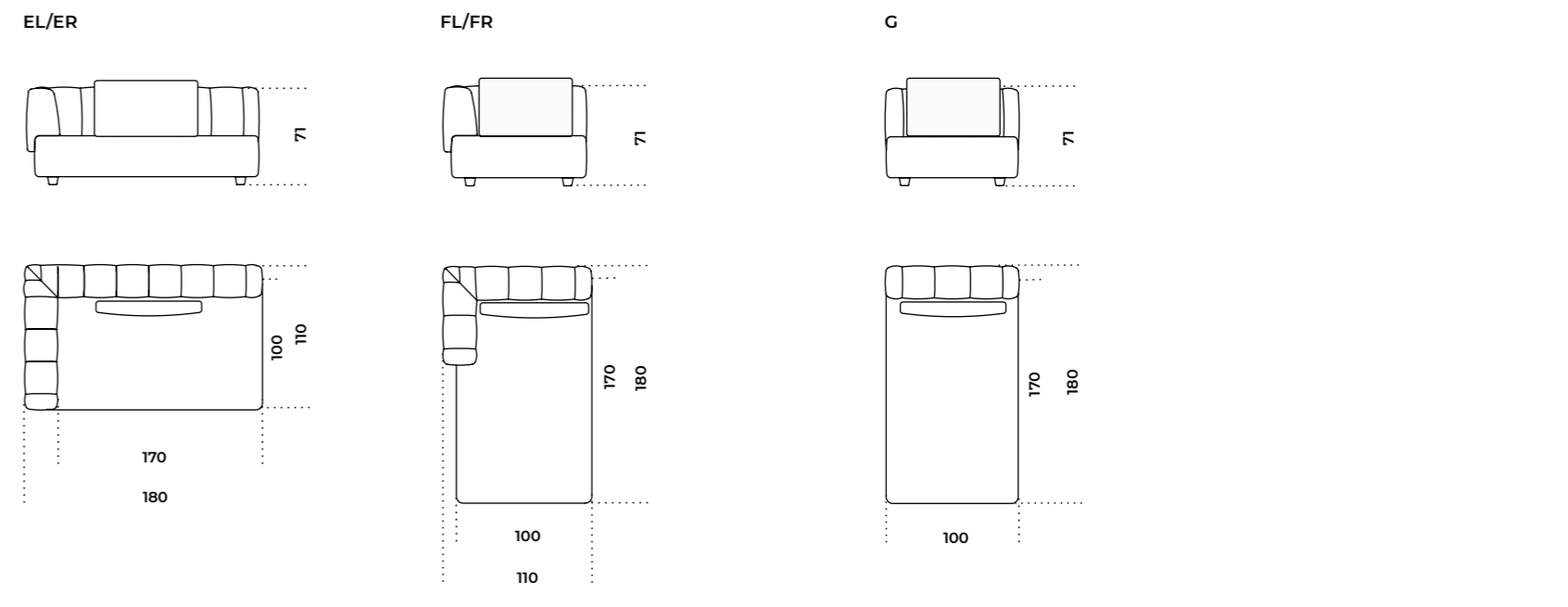
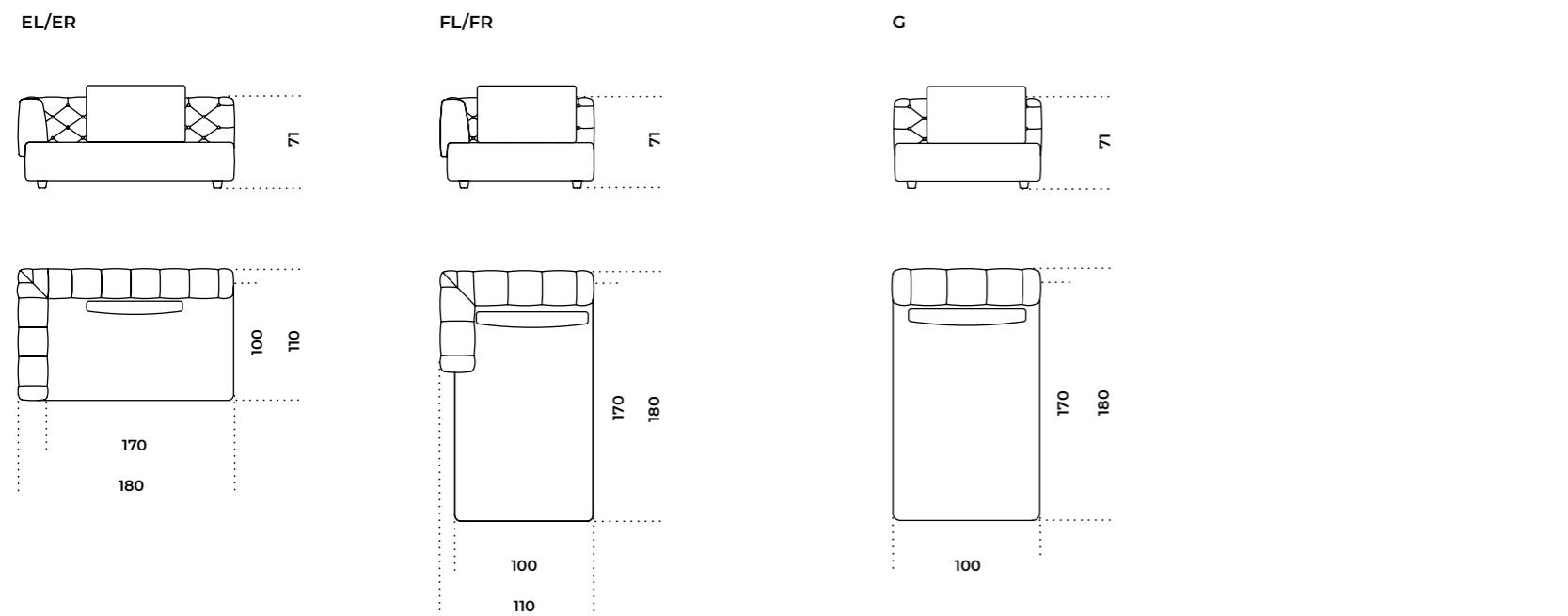
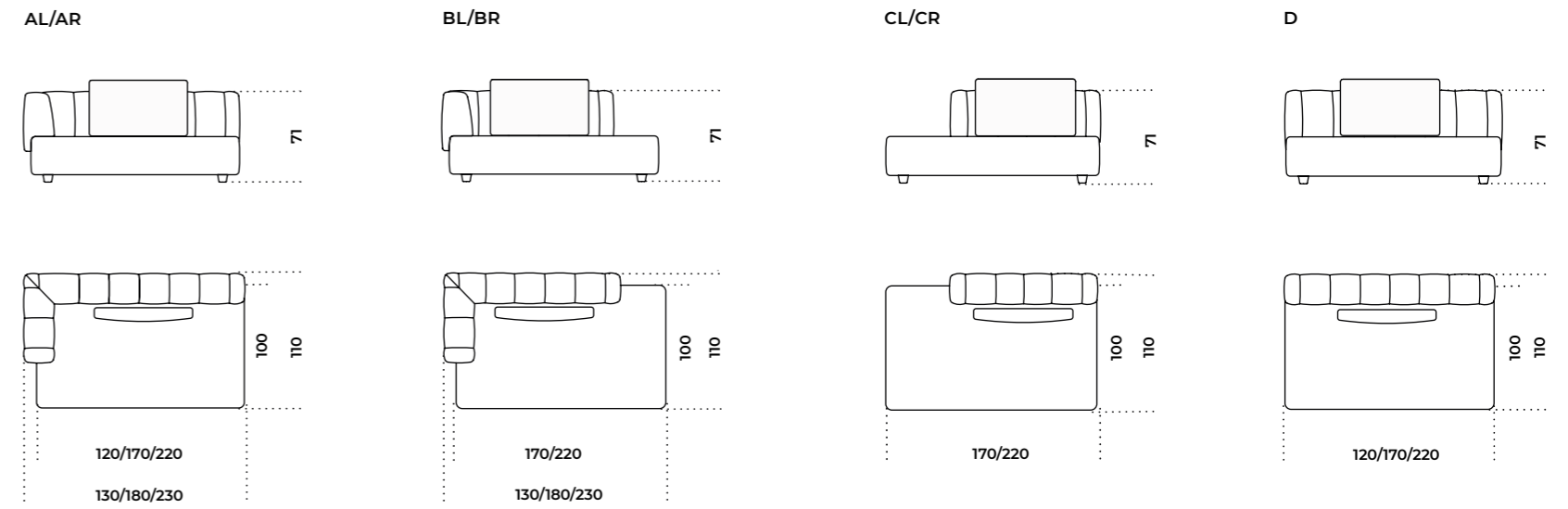

First | Massimo Castagna, 2014

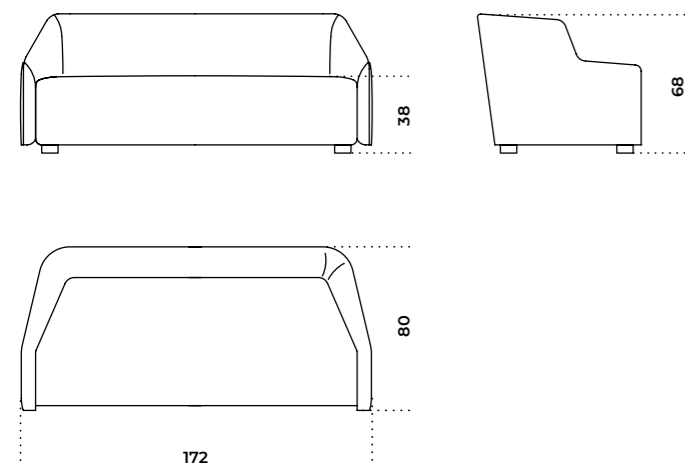

Product information / p. 178



Cuscino decorativo
Decorative cushion
35 x 25
14" x 10"
56 x 28
22¼" x 11¼"
40 x 40
15¾" x 15¾"

Lilas | Dainelli Studio, 2021

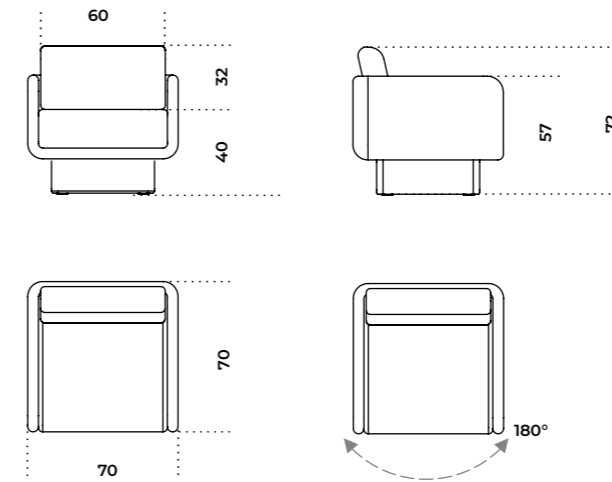

Product information / p. 184

First Modulare | Massimo Castagna, 2015

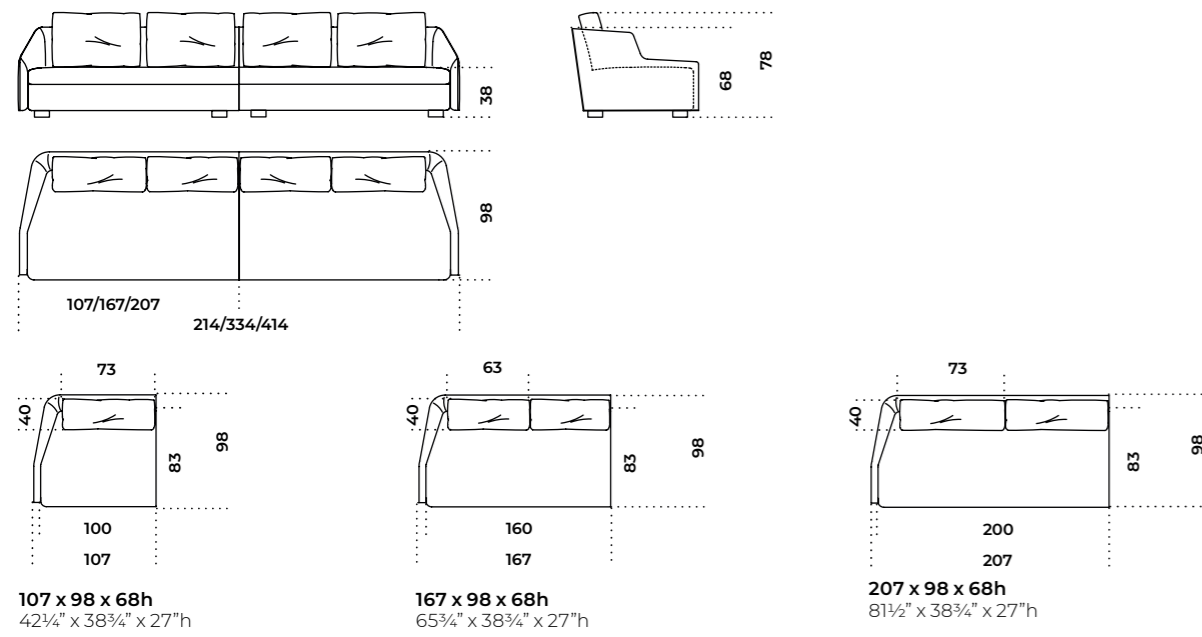

Product information / p. 180



Cuscino decorativo
Decorative cushion
35 x 25
14" x 10"
56 x 28
22¼" x 11¼"
40 x 40
15¾" x 15¾"

Lilas Mosaïque | Dainelli Studio, 2022

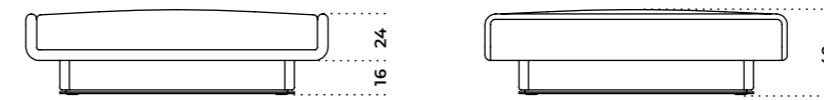

Product information / p. 186



Moduli
Modules

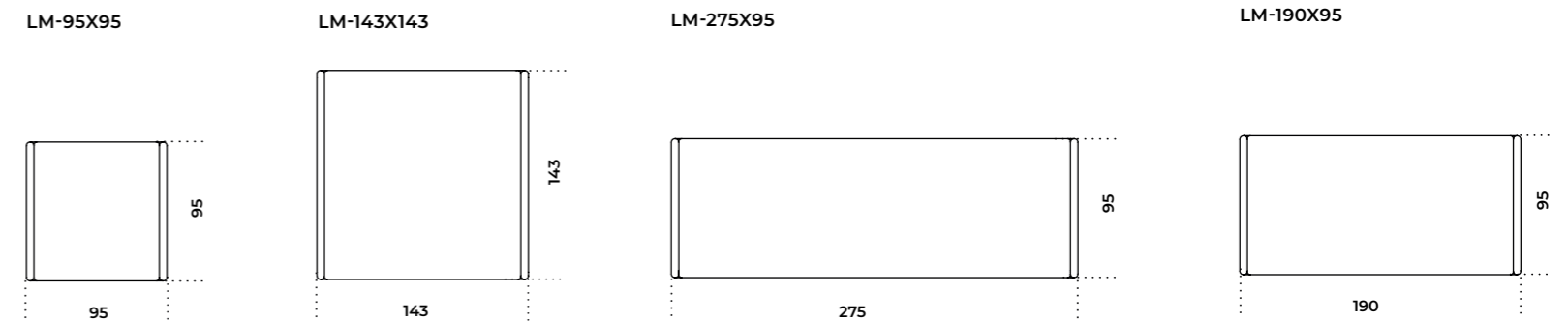

First Poltrona&Pouf | Massimo Castagna, 2015

Poltrona
Armchair

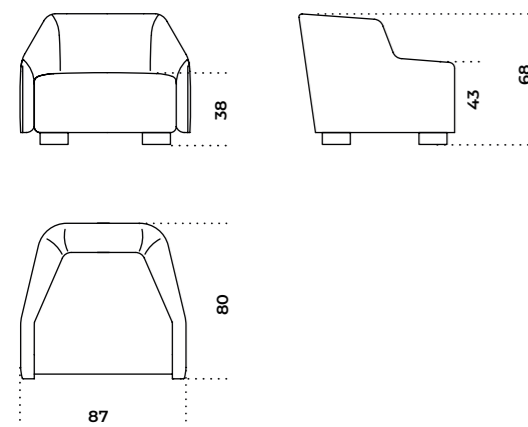

Pouf
Pouffe

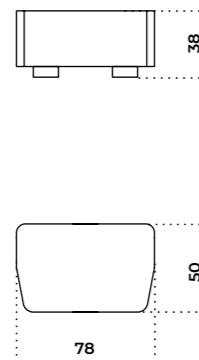

Product information / p. 182



Cuscino decorativo
Decorative cushion
35 x 25
14" x 10"

Posizione cuciture per versione in pelle/pelle scamosciata
Stitching position for leather/suede version

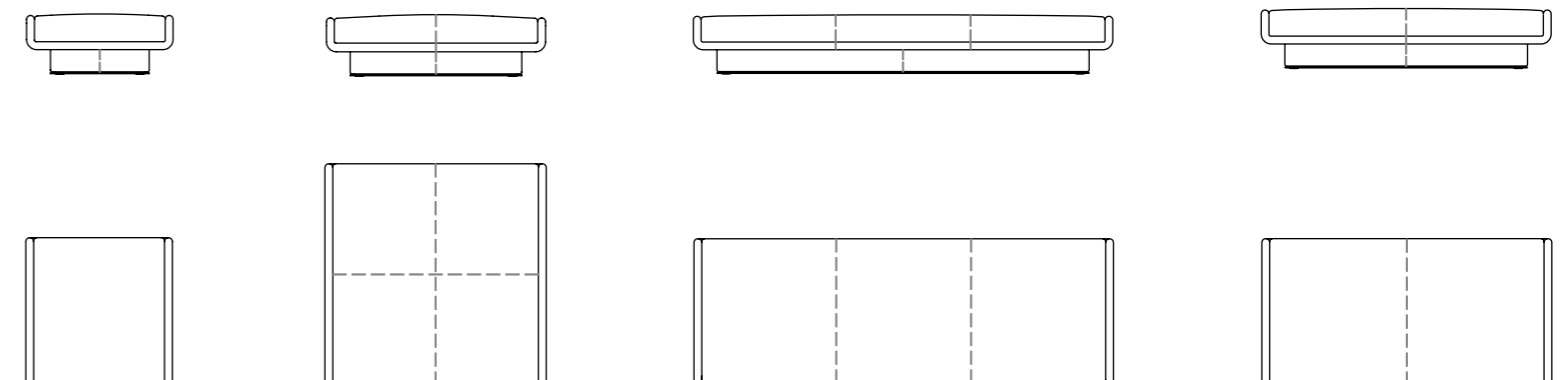

Composizioni
 Compositions

[Product information / p. 186](#)
Composizione 1 / Composition 1
333 x 370 x 40h
 131¼" x 145¾" x 15¾"h

Composta da
 Composed by

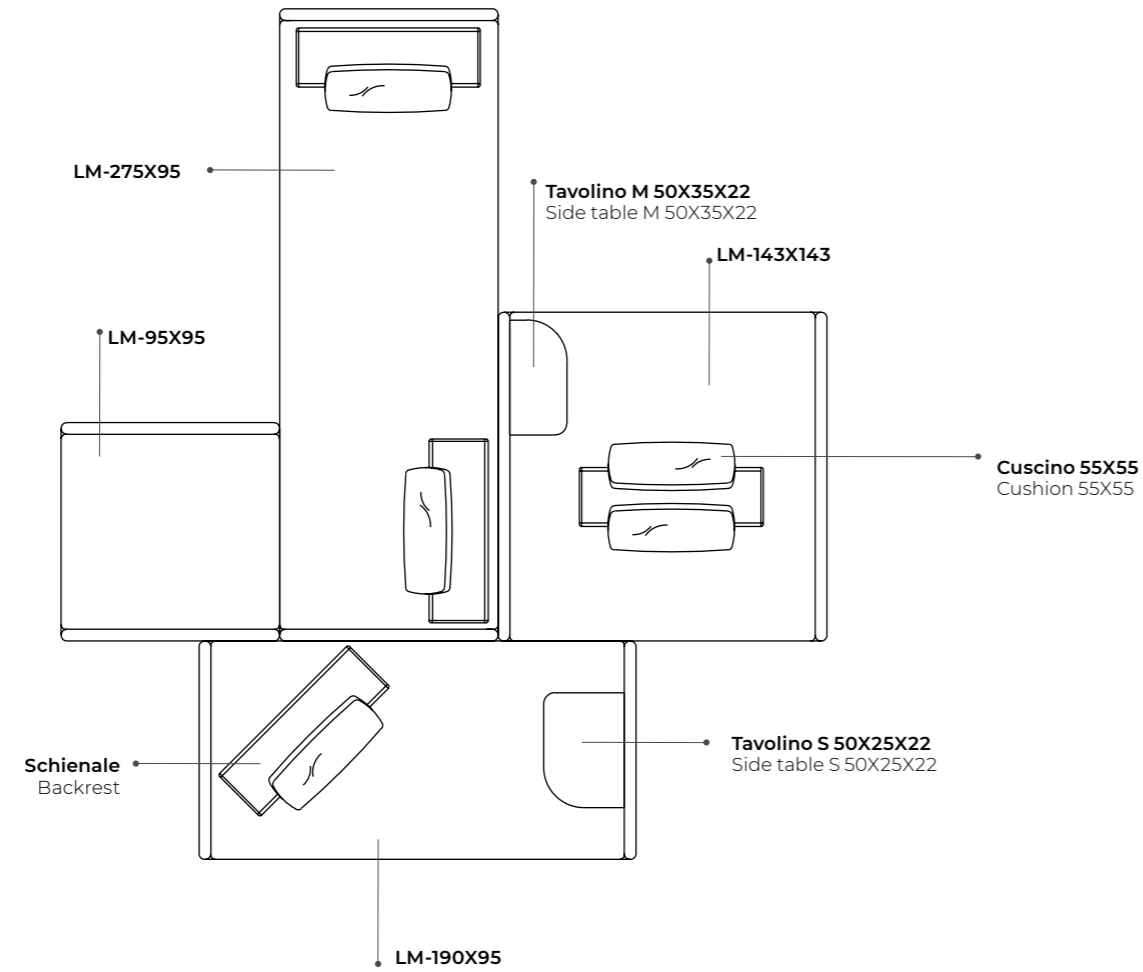
 n.1 LM-95X95
 n.1 LM-275X95
 n.1 LM-143X143
 n.1 LM-190X95
 n.4 Backrest
 n.5 Cushion 55X55
 n.1 Side table M 50X35X22
 n.1 Side table S 50X25X22

Composizione 2 / Composition 2
333 x 286 x 40h
 131¼" x 112¾" x 15¾"h

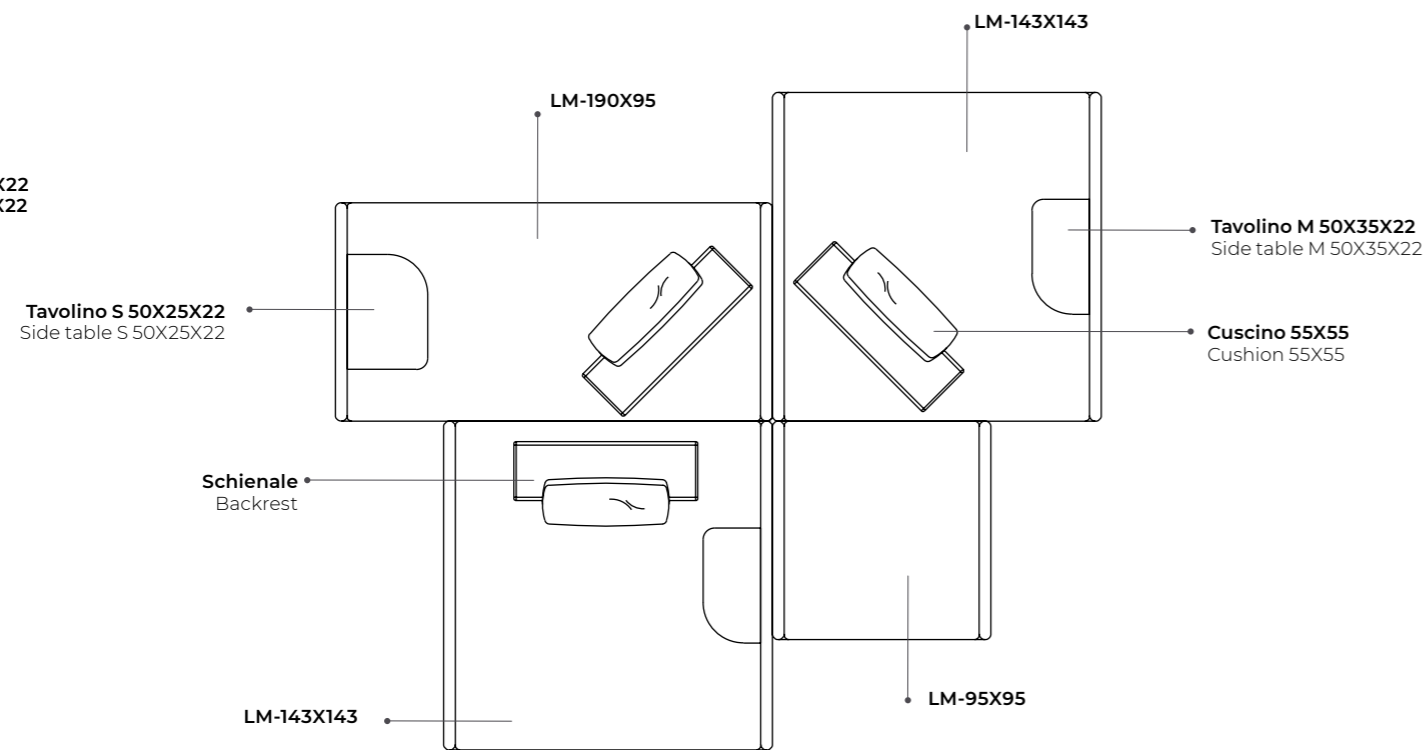
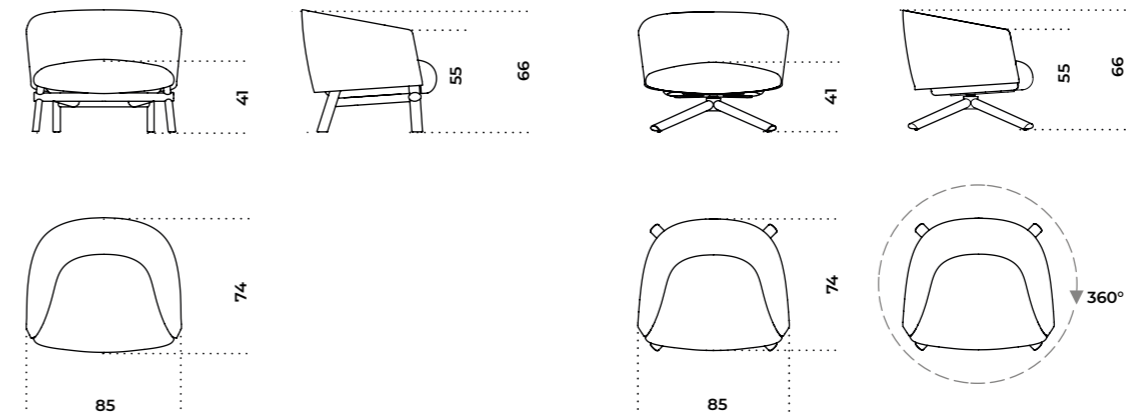
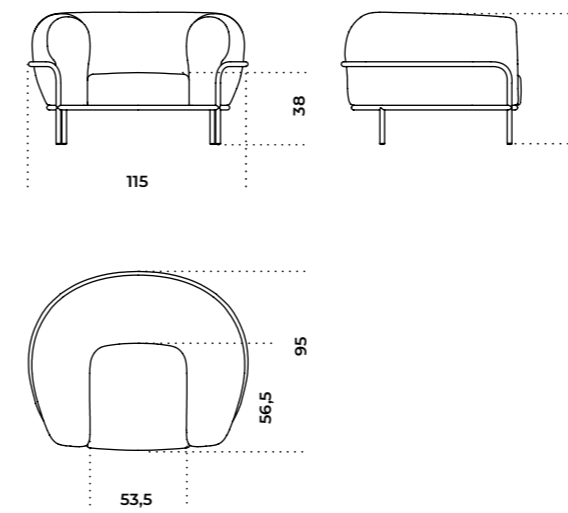
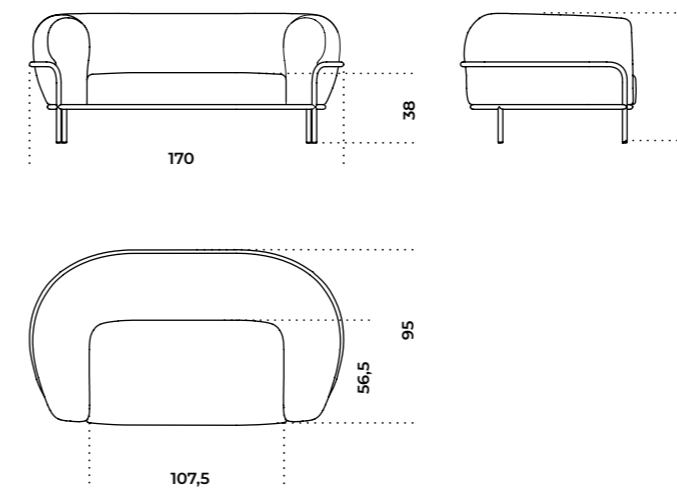
Composta da
 Composed by

 n.1 LM-95X95
 n.2 LM-143X143
 n.1 LM-190X95
 n.3 Backrest
 n.3 Cushion 55X55
 n.1 Side table M 50X35X22
 n.2 Side table S 50X25X22

Livre | Federica Biasi, 2020
[Product information / p. 188](#)
Versione girevole
 Swivel version

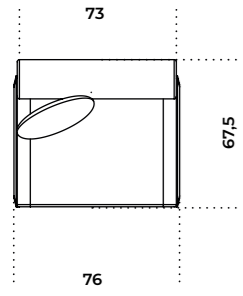
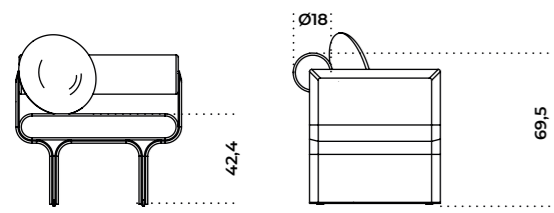
Sophie | Federica Biasi, 2018
[Product information / p. 190](#)

Sophie Sofa | Federica Biasi, 2019
[Product information / p. 192](#)

Stami Lounge | Studiopepe, 2023

[Product information / p.194](#)



06 Tavolini /

Coffee Tables

226	<u>1968</u>
228	<u>Chantal</u>
230	<u>Clemo</u>
234	<u>Connection</u>
236	<u>Cookies</u>
238	<u>Cookies Circle</u>
240	<u>Dama</u>
242	<u>Drummers</u>
244	<u>Fante</u>
246	<u>Faraday</u>
248	<u>George 1</u>
250	<u>George 2</u>
252	<u>Golden Moon</u>
254	<u>Gong</u>
256	<u>Haumea</u>
260	<u>Monete</u>
264	<u>Nori</u>
266	<u>Nox</u>
268	<u>Oto Mini</u>
270	<u>Prism Low</u>
272	<u>Raj 1</u>
274	<u>Raj 2</u>
276	<u>Raj 3</u>
278	<u>Raj 6</u>
280	<u>Re-verre</u>
282	<u>Selce</u>
284	<u>Sensei</u>
286	<u>Sir T 32/Sir T 32 C</u>
288	<u>T33</u>
290	<u>T35 R</u>
292	<u>T 35 Trio</u>
294	<u>Tetris</u>
296	<u>Twelve</u>
298	<u>Zen Black Low</u>
300	<u>Zen Low</u>
302	<u>Informazioni tecniche/ Technical informations</u>



▲ 1968

Piano marmo lucido naturale Verde Alpi / Base in ottone brunito a mano e frassino tinto nero poro aperto
Natural polished Verde Alpi marble top / Hand burnished brass and black open pore stained ash base

1968

Studio G&R / 2019

Tavolino con piano in marmo lucido naturale Verde Alpi, Calacatta Vagli Oro o Nero Marquinia. Struttura in ottone brunito a mano e parti in frassino tinto nero poro aperto.

NOTE TECNICHE SUI MATERIALI

MARMO | Il marmo è un materiale naturale di origine sedimentaria che può presentare particolarità come venature, lievi irregolarità superficiali, colorazioni differenti e cristallizzazioni. Queste peculiarità sono da attribuirsi alla naturalezza del materiale e non sono da considerarsi difetti ma caratteristiche tipiche del marmo. Ogni prodotto risulterà unico, esclusivo e non replicabile.

I nostri marmi vengono trattati con un prodotto idrorepellente che permette una maggiore protezione della superficie stessa, aumentando l'impermeabilità. Questo trattamento non esclude la vulnerabilità del marmo alle sostanze acide.

OTTONE BRUNITO A MANO | L'ottone brunito a mano è ottenuto da un processo di ossidazione naturale eseguito manualmente. Il risultato di questa lavorazione è un prodotto che può presentare macchie e variazioni di colore che non sono da considerarsi imperfezioni ma caratteristiche che conferiscono ad ogni pezzo una particolare unicità, rendendolo esclusivo.

! Sconsigliato posizionamento su tappeto.

Coffee table with natural polished Verde Alpi, Calacatta Vagli Oro or Nero Marquinia marble top. Hand burnished brass structure with black open pore stained ash parts.

TECHNICAL INFORMATION ON THE MATERIALS

MARBLE | The marble is a natural material of sedimentary origin that can present particularities such as veins, slight surface irregularities, different colors and crystallizations. These peculiarities are to be attributed to the naturalness of the material and are not to be considered defects but typical characteristics of marble. Each product will be unique, exclusive and non-replicable.

Our marbles are treated with water-repellent products which affords greater protection to the surface of the marble, improving its impermeability. This treatment doesn't exclude the vulnerability of the marble to acid substances.

HAND BURNISHED BRASS | The hand burnished brass is the consequence of hand-made process of natural oxidation. The result of this processing is a product that may show marks and colour variations. These differences are inevitable and should not be considered imperfections but evidence of the hand-crafted process. They enhance the beauty and distinctiveness of a unique piece.

! Not recommended for positioning on carpet.



Cm
Ø49 x 45
Ø49 x 50

Inches
Ø19½" x 17¾"
Ø19½" x 19¾"

For technical drawing / p. 306

Pricelist 2023 / p. 120
Homescapes, sense of materials / p. 32
Homescapes, embracing beauty / p. 25
Homescapes, gentle attitude / pp. 92, 93

PIANO/TOP



Marmo lucido naturale
Calacatta Vagli Oro
Natural polished
Calacatta Vagli Oro marble



Marmo lucido naturale
Verde Alpi
Natural polished
Verde Alpi marble



Marmo lucido naturale
Nero Marquinia
Natural polished
Nero Marquinia marble

STRUTTURA/STRUCTURE



Ottone brunito a mano/
Frassino tinto nero poro aperto
Hand burnished brass/
Black open pore stained ash



* CHANTAL
 Piano e struttura in alluminio spazzolato oro / Piano e struttura in alluminio spazzolato nero
 Gold brushed aluminium top and structure / Black brushed aluminium top and structure

Chantal

Studio G&R / 2013

Tavolino con piano e struttura in alluminio spazzolato a mano nei colori nero o oro.

Coffee table with top and structure in hand-brushed aluminium in the colours black or gold.



	Cm	Inches
A	40 x 40 x 50	15 ³ / ₄ " x 15 ³ / ₄ " x 19 ³ / ₄ "
B	60 x 60 x 45	23 ³ / ₄ " x 23 ³ / ₄ " x 17 ³ / ₄ "
C	60 x 60 x 30	23 ³ / ₄ " x 23 ³ / ₄ " x 12"
D	60 x 60 x 25	23 ³ / ₄ " x 23 ³ / ₄ " x 10"

[For technical drawing / p. 306](#)

[Pricelist 2023 / p. 121](#)

PIANO E STRUTTURA/TOP AND STRUCTURE



Alluminio spazzolato nero
 Black brushed aluminium



Alluminio spazzolato oro
 Gold brushed aluminium

Clemo

Massimo Castagna / 2021

Tavolino in Ceppo di Gré® spazzolato, con dettagli in metallo brunito a mano "dark". Disponibile anche in marmo Calacatta Vagli Oro lucido naturale, Bianco Carrara Gioia lucido naturale, Fior di Pesco spazzolato oppure Travertino Romano spazzolato naturale (non resinato)

Coffee table in brushed Ceppo di Gré® with "dark" hand burnished metal details. Also available in natural polished Calacatta Vagli Oro, natural polished Bianco Carrara Gioia marble, Fior di Pesco brushed marble or natural brushed Travertino Romano (not treated with resin)

NOTE TECNICHE SUI MATERIALI

CEPPO DI GRÉ® - MARMO | Il marmo è un materiale naturale di origine sedimentaria che può presentare particolarità come venature, lievi irregolarità superficiali, colorazioni differenti e cristallizzazioni. Queste peculiarità sono da attribuirsi alla naturalezza del materiale e non sono da considerarsi difetti ma caratteristiche tipiche del marmo. Ogni prodotto risulterà unico, esclusivo e non replicabile. I nostri marmi vengono trattati con un prodotto idrorepellente che permette una maggiore protezione della superficie stessa, aumentando l'impermeabilità. Questo trattamento non esclude la vulnerabilità del marmo alle sostanze acide.

TECHNICAL INFORMATION ON THE MATERIALS

CEPPO DI GRÉ® - MARBLE | The marble is a natural material of sedimentary origin that can present particularities such as veins, slight surface irregularities, different colors and crystallizations. These peculiarities are to be attributed to the naturalness of the material and are not to be considered defects but typical characteristics of marble. Each product will be unique, exclusive and non-replicable. Our marbles are treated with water-repellent products which affords greater protection to the surface of the marble, improving its impermeability. This treatment doesn't exclude the vulnerability of the marble to acid substances.



Cm

Ø 49 x 40
Ø 90 x 31,5
Ø 120 x 28

Inches

19½" x 15¾"
35½" x 12½"
47¼" x 11¼"

[For technical drawing / p. 306](#)

[Pricelist 2023 / p. 122](#)
[Homescapes, intimate portraits / pp. 17, 23, 65, 71](#)
[Homescapes, gentle attitude / pp. 22, 25, 92, 93](#)

STRUTTURA/STRUCTURE

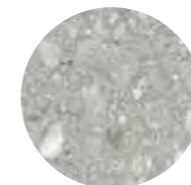

Ceppo di Gré® spazzolato
Brushed Ceppo di Gré®

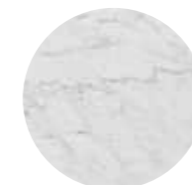

Marmo lucido naturale Bianco Carrara Gioia
Natural polished Bianco Carrara Gioia marble



Marmo lucido naturale Calacatta Vagli Oro
Natural polished Calacatta Vagli Oro marble



Marmo spazzolato Fior di Pesco
Fior di Pesco brushed marble

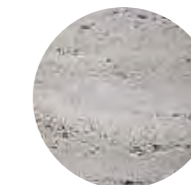

Travertino Romano spazzolato naturale
Natural brushed Travertino Romano



Metallo brunito a mano "dark"
"Dark" hand burnished metal

DETTAGLI/DETAILS



• CLEMO
Marmo lucido naturale Bianco Carrara Gioia
Natural polished Bianco Carrara Gioia marble



• CLEMO
Marmo lucido naturale Calacatta Vagli Oro
Natural polished Calacatta Vagli Oro marble



• CLEMO
Marmo lucido naturale Bianco Carrara Gioia
Natural polished Bianco Carrara Gioia marble

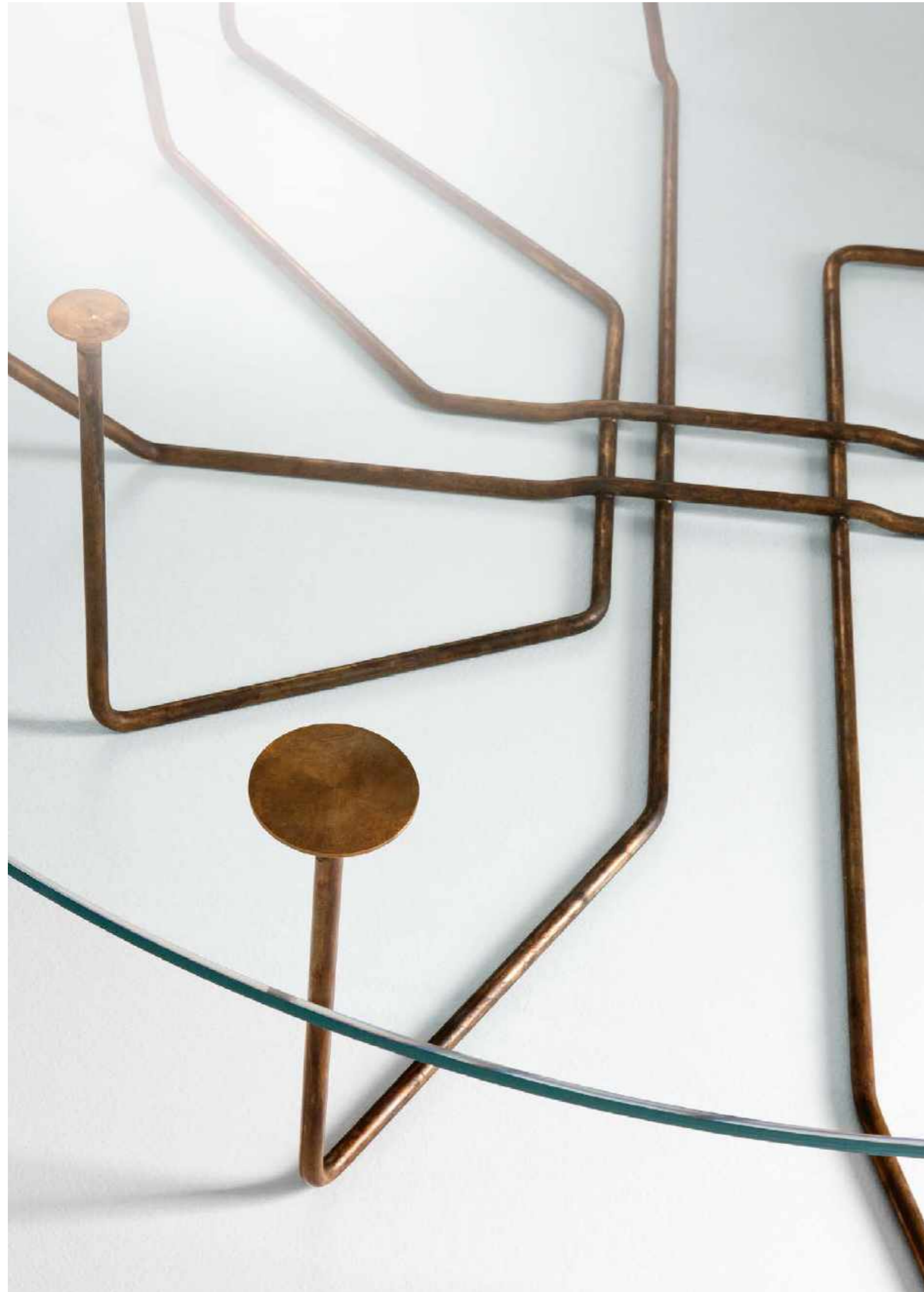

Connection

Massimo Castagna / 2013

Tavolino in cristallo extralight. Struttura in ottone brunito a mano. L'ottone risulta naturalmente macchiato e disomogeneo. Questa lavorazione artigianale conferisce ad ogni pezzo una particolare unicità, rendendolo esclusivo.

NOTE TECNICHE SUI MATERIALI

OTTONE BRUNITO A MANO | L'ottone brunito a mano è ottenuto da un processo di ossidazione naturale eseguito manualmente. Il risultato di questa lavorazione è un prodotto che può presentare macchie e variazioni di colore che non sono da considerarsi imperfezioni ma caratteristiche che conferiscono ad ogni pezzo una particolare unicità, rendendolo esclusivo.

- ! Non realizzabile su misura.
- ! Cristallo temperato solo per spessore 12mm.

Coffee table with extralight glass. Structure in hand burnished brass. The hand burnished brass finish looks naturally spotted and irregular. Due to this craftmade processing, each product is unique and exclusive.

TECHNICAL INFORMATION ON THE MATERIALS

HAND BURNISHED BRASS | The hand burnished brass is the consequence of hand-made process of natural oxidation. The result of this processing is a product that may show marks and colour variations. These differences are inevitable and should not be considered imperfections but distinctive features due to this craftmade processing, each product is unique and exclusive.

- ! Not available in custom size.
- ! Tempered glass only for thickness 12mm.



Cm

Spessore 10mm
 Ø50 x 46,5
 Ø70 x 39,5
 Double 107 x 70 x 46,5

Spessore 12mm

Ø100 x 32
 Ø130 x 32
 100 x 100 x 32
 130 x 130 x 32
 140 x 70 x 32
 180 x 76 x 32

Inches

Thickness 10mm
 Ø19¾" x 18½"
 Ø27¾" x 15¾"
 42½" x 27¾" x 18½"

Thickness 12mm

Ø39½" x 12¾"
 Ø51¼" x 12¾"
 39½" x 39½" x 12¾"
 51¼" x 51¼" x 12¾"
 55¼" x 27¾" x 12¾"
 71" x 30" x 12¾"

For technical drawing / p. 307

Pricelist 2023 / p. 123
 Homescapes, sense of materials / p. 32

PIANO/TOP



Cristallo extralight
 Extralight glass

STRUTTURA/STRUCTURE



Ottone brunito a mano
 Hand burnished brass

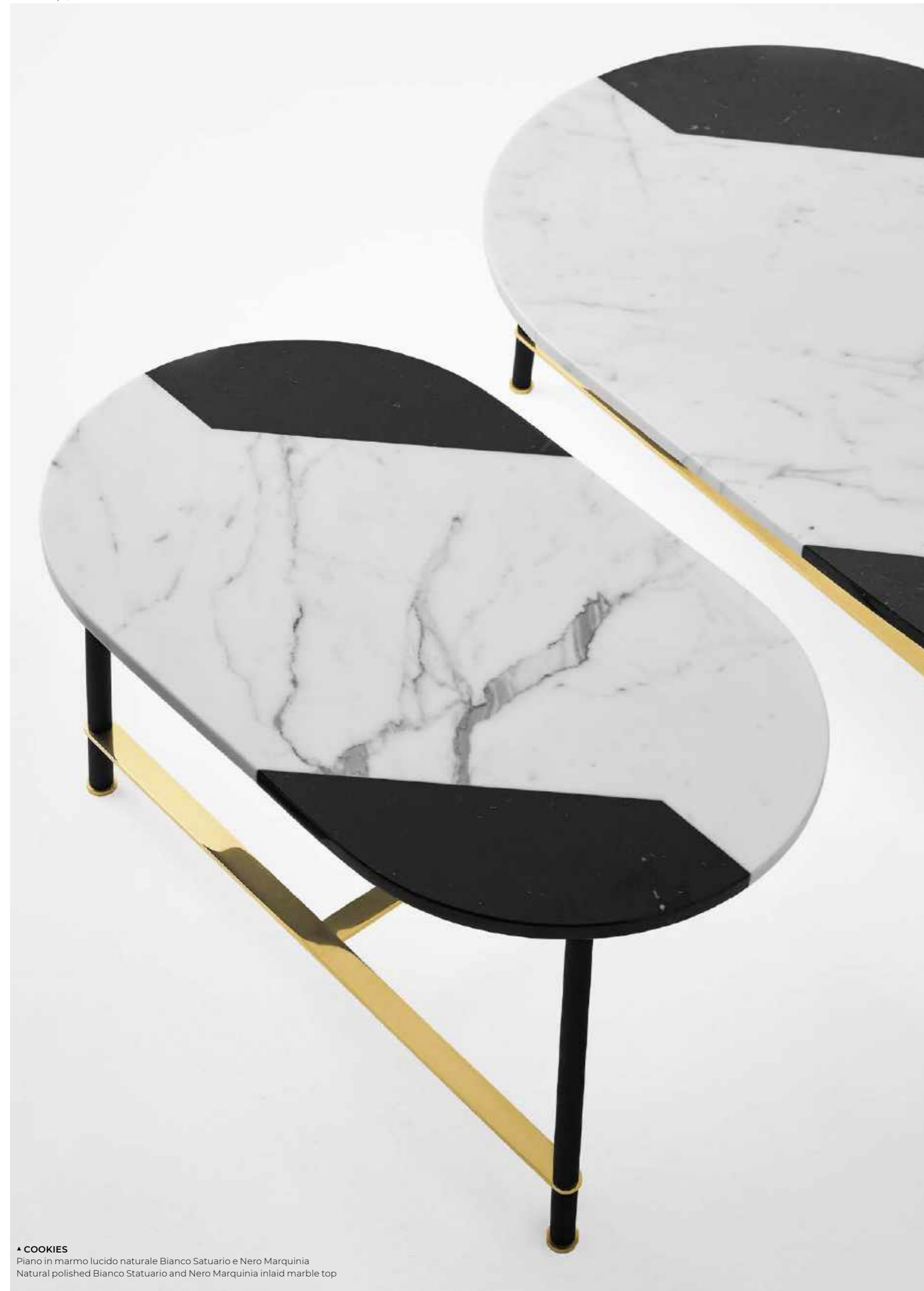

▲ **COOKIES**
Piano in marmo lucido naturale Bianco Statuario e Nero Marquinia
Natural polished Bianco Statuario and Nero Marquinia inlaid marble top

Cookies

Pietro Russo / 2017

Tavolino con piano in marmo lucido naturale Bianco Statuario e Nero Marquinia intarsiato. Disponibile anche con piano in legno intarsiato con motivo "Tweed" oppure in Acero Frisé grigio scuro.
Struttura in alluminio spazzolato a mano e anodizzato nero ed ottone lucido.
Disponibile versione con piano in marmo lucido naturale Calacatta Vagli Oro e struttura in metallo verniciato bronzo patinato.

NOTE TECNICHE SUI MATERIALI

MARMO | Il marmo è un materiale naturale di origine sedimentaria che può presentare particolarità come venature, lievi irregolarità superficiali, colorazioni differenti e cristallizzazioni. Queste peculiarità sono da attribuirsi alla naturalezza del materiale e non sono da considerarsi difetti ma caratteristiche tipiche del marmo. Ogni prodotto risulterà unico, esclusivo e non replicabile.
I nostri marmi vengono trattati con un prodotto idrorepellente che permette una maggiore protezione della superficie stessa, aumentando l'impermeabilità. Questo trattamento non esclude la vulnerabilità del marmo alle sostanze acide.

INTARSIO | L'intarsio è una tecnica di lavorazione artigianale utilizzata per ottenere un particolare disegno e si realizza accostando elementi di materiali differenti (come legno e alluminio) oppure dello stesso materiale. Questa lavorazione rende il prodotto unico ed esclusivo. Le eventuali variazioni cromatiche, di venatura del legno o di dimensione dei listelli sono da considerarsi caratteristiche del materiale stesso e non possono essere controllate.

Coffee table with natural polished Bianco Statuario and Nero Marquinia marble inlaid top. Also available with inlaid wooden top with "Tweed" pattern or in Maple Frisé dark grey.
Black hand brushed anodized aluminium and bright brass structure.
Also available version with natural polished Calacatta Vagli marble top and patinated bronze lacquered metal structure

TECHNICAL INFORMATION ON THE MATERIALS

MARBLE | The marble is a natural material of sedimentary origin that can present particularities such as veins, slight surface irregularities, different colors and crystallizations. These peculiarities are to be attributed to the naturalness of the material and are not to be considered defects but typical characteristics of marble. Each product will be unique, exclusive and non-replicable.
Our marbles are treated with water-repellent products which affords greater protection to the surface of the marble, improving its impermeability. This treatment doesn't exclude the vulnerability of the marble to acid substances.

INLAY | Inlay is an artisanal technique used to obtain a particular design and is made by combining elements of different materials (such as wood and aluminium) or of the same material. This process makes the product unique and exclusive. Any changes in colour, wood grain or strip size are to be considered as characteristics of the material itself and cannot be controlled.



Versione in marmo
Marble version

	Cm	Inches
S	70 x 42 x 40	27¾" x 16¾" x 15¾"
M	105 x 62 x 28	41½" x 24½" x 11¼"
L	120 x 72 x 23	47½" x 28½" x 9¼"

Versione in legno
Wooden version

	Cm	Inches
S	70 x 42 x 40	27¾" x 16¾" x 15¾"
M	105 x 62 x 28	41½" x 24½" x 11¼"
L	120 x 72 x 23	47½" x 28½" x 9¼"
XL	144 x 86 x 35	56¾" x 34" x 14"

[For technical drawing / p. 307](#)

[Pricelist 2023 / p. 125](#)
[Homescapes, sense of materials / pp. 19, 22](#)
[Homescapes, gentle attitude / pp. 86, 88](#)

VERSIONI DISPONIBILI/AVAILABLE VERSIONS

PIANO/TOP



Marmo Bianco Statuario/
Nero Marquinia
lucido naturale
Bianco Statuario/
Nero Marquinia marble
natural polished

PIANO/TOP



Legno Acero Frisé
grigio scuro
Maple Frisé dark grey wood

STRUTTURA/STRUCTURE

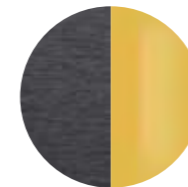

Alluminio spazzolato nero/
Ottone lucido
Black brushed aluminium/
Bright brass

STRUTTURA/STRUCTURE

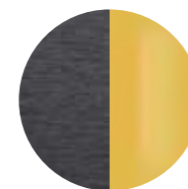

Alluminio spazzolato nero/
Ottone lucido
Black brushed aluminium/
Bright brass

PIANO/TOP



Legno intarsiato
con motivo "Tweed"
Inlaid wood with
"Tweed" pattern

PIANO/TOP



Marmo lucido naturale
Calacatta Vagli Oro
Natural polished Calacatta
Vagli Oro marble

STRUTTURA/STRUCTURE

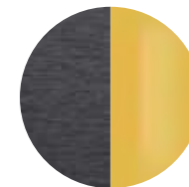

Alluminio spazzolato nero/
Ottone lucido
Black brushed aluminium/
Bright brass

STRUTTURA/STRUCTURE

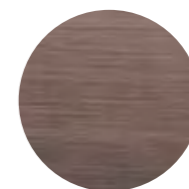

Metallo verniciato
bronzo patinato
Patinated bronze
lacquered metal

Cookies Circle

Pietro Russo / 2019

Tavolino con piano in marmo lucido naturale Verde Alpi, Calacatta Vagli Oro, Bianco Statuario, Nero Marquinia o Travertino Romano spazzolato naturale (non resinato). Struttura in alluminio spazzolato a mano anodizzato nero ed ottone lucido oppure in metallo verniciato bronzo patinato.

Disponibile anche versione con piano in legno intarsiato nella finitura Noce "Colore" Frisé oppure Acero Frisé grigio scuro e struttura in alluminio spazzolato a mano anodizzato nero ed ottone lucido

NOTE TECNICHE SUI MATERIALI

MARMO | Il marmo è un materiale naturale di origine sedimentaria che può presentare particolarità come venature, lievi irregolarità superficiali, colorazioni differenti e cristallizzazioni. Queste peculiarità sono da attribuirsi alla naturalezza del materiale e non sono da considerarsi difetti ma caratteristiche tipiche del marmo. Ogni prodotto risulterà unico, esclusivo e non replicabile.

I nostri marmi vengono trattati con un prodotto idrorepellente che permette una maggiore protezione della superficie stessa, aumentando l'impermeabilità. Questo trattamento non esclude la vulnerabilità del marmo alle sostanze acide.

INTARSIO | L'intarsio è una tecnica di lavorazione artigianale utilizzata per ottenere un particolare disegno e si realizza accostando elementi di materiali differenti (come legno e alluminio) oppure dello stesso materiale. Questa lavorazione rende il prodotto unico ed esclusivo. Le eventuali variazioni cromatiche e di venatura del legno sono da considerarsi caratteristiche del materiale stesso e non possono essere controllate.

Coffee table with natural polished Verde Alpi, Calacatta Vagli Oro, Bianco Statuario, Nero Marquinia marble to or natural brushed Travertino Romano (not treated with resin). Black hand brushed anodized aluminium and bright brass structure or patinated bronze lacquered metal structure.

Also available with inlaid wooden top in the finish "Colore" Frisé Walnut or in Maple Frisé dark grey. Black hand brushed anodized aluminium and bright brass structure

TECHNICAL INFORMATION ON THE MATERIALS

MARBLE | The marble is a natural material of sedimentary origin that can present particularities such as veins, slight surface irregularities, different colors and crystallizations. These peculiarities are to be attributed to the naturalness of the material and are not to be considered defects but typical characteristics of marble. Each product will be unique, exclusive and non-replicable.

Our marbles are treated with water-repellent products which affords greater protection to the surface of the marble, improving its impermeability. This treatment doesn't exclude the vulnerability of the marble to acid substances.

INLAY | Inlay is an artisanal technique used to obtain a particular design and is made by combining elements of different materials (such as wood and aluminium) or of the same material. This process makes the product unique and exclusive. Any colour and grain variations of the wood are to be considered as characteristics of the material itself and cannot be controlled.



▲ COOKIES CIRCLE

Piano in marmo lucido naturale Calacatta Vagli Oro /
Struttura in alluminio spazzolato nero e ottone lucido
Natural polished Calacatta Vagli Oro marble top /
Black brushed aluminium and bright brass

▲ COOKIES CIRCLE

Piano in marmo lucido naturale Verde Alpi / Struttura in alluminio spazzolato nero e ottone lucido
Natural polished Verde Alpi marble top / Black brushed aluminium and bright brass

For technical drawing / p. 308

Pricelist 2023 / p. 125
Homescapes, sense of materials / p. 22
Homescapes, intimate portraits / p. 102
Homescapes, gentle attitude / pp. 58, 86, 88

Cm
S Ø49 x 35
L Ø49 x 45

Inches
S Ø19½" x 14"
L Ø19½" x 17¾"

PIANO/TOP



Marmo lucido naturale Verde Alpi
Natural polished Verde Alpi marble

STRUTTURA/STRUCTURE

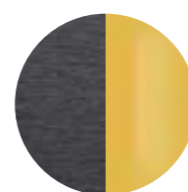

Alluminio spazzolato nero/ Ottone lucido
Black brushed aluminium/ Bright brass

PIANO/TOP



Marmo lucido naturale Verde Alpi
Natural polished Verde Alpi marble

STRUTTURA/STRUCTURE

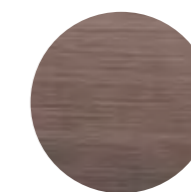

Metallo verniciato bronzo patinato
Patinated bronze lacquered metal

PIANO/TOP



Marmo lucido naturale Calacatta Vagli Oro
Natural polished Calacatta Vagli Oro marble

STRUTTURA/STRUCTURE

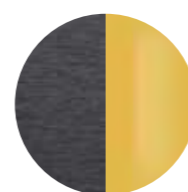

Alluminio spazzolato nero/ Ottone lucido
Black brushed aluminium/ Bright brass

PIANO/TOP



Marmo lucido naturale Calacatta Vagli Oro
Natural polished Calacatta Vagli Oro marble

STRUTTURA/STRUCTURE



Metallo verniciato bronzo patinato
Patinated bronze lacquered metal

PIANO/TOP



Marmo lucido naturale Bianco Statuario
Natural polished Bianco Statuario marble

STRUTTURA/STRUCTURE

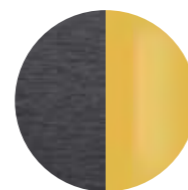

Alluminio spazzolato nero/ Ottone lucido
Black brushed aluminium/ Bright brass

PIANO/TOP



Marmo lucido naturale Bianco Statuario
Natural polished Bianco Statuario marble

STRUTTURA/STRUCTURE



Metallo verniciato bronzo patinato
Patinated bronze lacquered metal

PIANO/TOP



Marmo lucido naturale Nero Marquinia
Natural polished Nero Marquinia marble

STRUTTURA/STRUCTURE

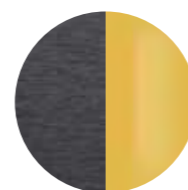

Alluminio spazzolato nero/ Ottone lucido
Black brushed aluminium/ Bright brass

PIANO/TOP



Marmo lucido naturale Nero Marquinia
Natural polished Nero Marquinia marble

STRUTTURA/STRUCTURE



Metallo verniciato bronzo patinato
Patinated bronze lacquered metal

PIANO/TOP



Travertino Romano spazzolato naturale
Natural brushed Travertino Romano

STRUTTURA/STRUCTURE

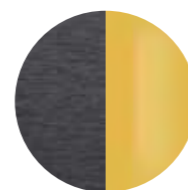

Alluminio spazzolato nero/ Ottone lucido
Black brushed aluminium/ Bright brass

PIANO/TOP



Travertino Romano spazzolato naturale
Natural brushed Travertino Romano

STRUTTURA/STRUCTURE



Metallo verniciato bronzo patinato
Patinated bronze lacquered metal

PIANO/TOP



Legno Noce "Colore" Frisé
"Colore" Frisé Walnut wood

STRUTTURA/STRUCTURE

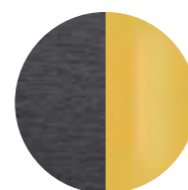

Alluminio spazzolato nero/ Ottone lucido
Black brushed aluminium/ Bright brass

PIANO/TOP



Legno Acero Frisé grigio scuro
Maple Frisé dark grey wood

STRUTTURA/STRUCTURE

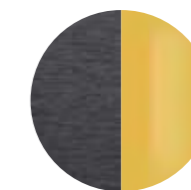

Alluminio spazzolato nero/ Ottone lucido
Black brushed aluminium/ Bright brass

Dama

Studio G&R / 2015

Tavolino in legno massello tinto nero poro aperto. Piano in specchio "grigio Italia". Disponibile anche in specchio "Antique 1" oppure marmo lucido naturale Calacatta Vagli Oro o marmo Verde Alpi.

Coffee table in black open pore stained solid wood. Smoked "grigio Italia" mirrored top. Also available in "Antique 1" mirror, natural polished Calacatta Vagli Oro or Verde Alpi marble.

! Il legno massello è molto sensibile alla luce, il posizionamento vicino a sorgenti di luce naturale ne compromette la colorazione e la stabilità. Un'elevata variazione della temperatura e umidità dell'aria può provocare la comparsa di microfratture e leggere variazioni.

! Solid wood is very light-sensitive, placing it near natural light sources may compromise its colour and stability. Considerable differences in air temperature and humidity may cause microfractures and slight variations.

NOTE TECNICHE SUI MATERIALI

MARMO | Il marmo è un materiale naturale di origine sedimentaria che può presentare particolarità come venature, lievi irregolarità superficiali, colorazioni differenti e cristallizzazioni. Queste peculiarità sono da attribuirsi alla naturalezza del materiale e non sono da considerarsi difetti ma caratteristiche tipiche del marmo. Ogni prodotto risulterà unico, esclusivo e non replicabile. I nostri marmi vengono trattati con un prodotto idrorepellente che permette una maggiore protezione della superficie stessa, aumentando l'impermeabilità. Questo trattamento non esclude la vulnerabilità del marmo alle sostanze acide.

TECHNICAL INFORMATION ON THE MATERIALS

MARBLE | The marble is a natural material of sedimentary origin that can present particularities such as veins, slight surface irregularities, different colors and crystallizations. These peculiarities are to be attributed to the naturalness of the material and are not to be considered defects but typical characteristics of marble. Each product will be unique, exclusive and non-replicable. Our marbles are treated with water-repellent products which affords greater protection to the surface of the marble, improving its impermeability. This treatment doesn't exclude the vulnerability of the marble to acid substances.



Piano in specchio Mirrored top

	Cm	Inches
S	Ø41 x 45	Ø16¼" x 17¾"
L	Ø38 x 55	Ø15" x 21¾"

Piano in marmo Marble top

	Cm	Inches
S	Ø41 x 46	Ø41 x 46
L	Ø38 x 56	Ø38 x 56

For technical drawing / p. 308

Pricelist 2023 / p. 126
Homescapes, sense of materials / p. 111
Homescapes, gentle attitude / pp. 37, 39, 41, 43, 72, 74

STRUTTURA / STRUCTURE

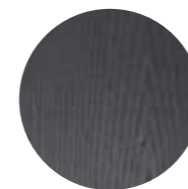

**Legno tinto
nero poro aperto**
Black open pore
stained wood

PIANO / TOP

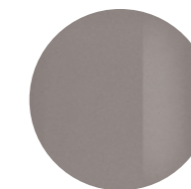

Specchio "grigio Italia"
"Grigio Italia" smoked mirror

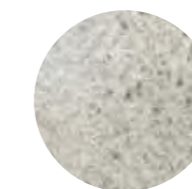

Specchio Antique 1
Antique 1 mirror



**Marmo lucido naturale
Calacatta Vagli Oro**
Natural polished
Calacatta Vagli Oro marble



**Marmo lucido naturale
Verde Alpi**
Natural polished
Verde Alpi marble

▲ DAMA
Piano in marmo Calacatta Vagli Oro / Struttura in legno tinto nero poro aperto
Calacatta Vagli Oro marble top / Black open pore stained solid wood structure



Drummers

Masismo Castagna / 2023

Tavolino in poliuretano rigido rivestito in calce spatolata nel color "burro".

Coffee table in rigid polyurethane covered with spatulated lime in the "burro" color.



Cm
Ø31 x 45
60,3 x 60,7 x 27
88,3 x 88,2 x 20

Inches
Ø12¼" x 17¾"
23¾" x 24" x 10¾"
35" x 34¾" x 8"

[For technical drawing / p. 308](#)

[Pricelist 2023 / p. 127](#)

STRUTTURA / STRUCTURE



Calce spatolata nel color "burro"
Spatulated lime in the "burro" color.



▲ FANTE
Piano in specchio Antique 1 / Struttura in legno tinto nero poro aperto
"Antique 1" mirrored top / Black open pore stained solid wood structure

Fante

Studio G&R / 2015

Tavolino in legno massello tinto nero poro aperto. Piano in specchio "grigio Italia". Disponibile anche in specchio "Antique 1" oppure marmo lucido naturale Calacatta Vagli Oro o marmo Verde Alpi.

! Sconsigliato posizionamento su tappeto.

Il legno massello è molto sensibile alla luce, il posizionamento vicino a sorgenti di luce naturale ne compromette la colorazione e la stabilità. Un'elevata variazione della temperatura e umidità dell'aria può provocare la comparsa di microfessure e leggere variazioni.

NOTE TECNICHE SUI MATERIALI

MARMO | Il marmo è un materiale naturale di origine sedimentaria che può presentare particolarità come venature, lievi irregolarità superficiali, colorazioni differenti e cristallizzazioni. Queste peculiarità sono da attribuirsi alla naturalezza del materiale e non sono da considerarsi difetti ma caratteristiche tipiche del marmo. Ogni prodotto risulterà unico, esclusivo e non replicabile. I nostri marmi vengono trattati con un prodotto idrorepellente che permette una maggiore protezione della superficie stessa, aumentando l'impermeabilità. Questo trattamento non esclude la vulnerabilità del marmo alle sostanze acide.

Coffee table in black open pore stained solid wood. Smoked "grigio Italia" mirrored top. Also available in "Antique 1" mirror, natural polished Calacatta Vagli Oro or Verde Alpi marble.

! Not recommended for positioning on carpet.

Solid wood is very light-sensitive, placing it near natural light sources may compromise its colour and stability. Considerable differences in air temperature and humidity may cause microfractures and slight variations.

TECHNICAL INFORMATION ON THE MATERIALS

MARBLE | The marble is a natural material of sedimentary origin that can present particularities such as veins, slight surface irregularities, different colors and crystallizations. These peculiarities are to be attributed to the naturalness of the material and are not to be considered defects but typical characteristics of marble. Each product will be unique, exclusive and non-replicable. Our marbles are treated with water-repellent products which affords greater protection to the surface of the marble, improving its impermeability. This treatment doesn't exclude the vulnerability of the marble to acid substances.



Piano in specchio
Mirrored top

	Cm	Inches
S	Ø46 x 50	Ø18¼" x 19¾"
L	Ø38 x 63	Ø15" x 25"

Piano in marmo
Marble top

	Cm	Inches
S	Ø46 x 51	Ø18¼" x 20¼"
L	Ø38 x 64	Ø15" x 25¼"

[For technical drawing / p.309](#)

[Pricelist 2023 / p.128](#)
[Homescapes, sense of materials / p.73](#)
[Homescapes, embracing beauty / p.55](#)
[Homescapes, gentle attitude / pp.37,39,41,43,72,74](#)

STRUTTURA/STRUCTURE

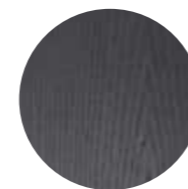

Legno tinto nero poro aperto
Black open pore stained wood

PIANO/TOP

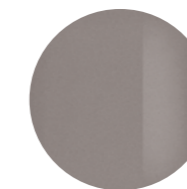

Specchio "grigio Italia"
"Grigio Italia" smoked mirror

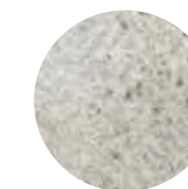

Specchio Antique 1
Antique 1 mirror



Marmo lucido naturale Calacatta Vagli Oro
Natural polished Calacatta Vagli Oro marble

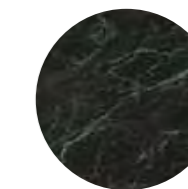

Marmo lucido naturale Verde Alpi
Natural polished Verde Alpi marble

Faraday

Mårten Claesson, Ola Rune, Eero Koivisto / 2007

Tavolino con piano superiore in cristallo trasparente temperato 8mm e piano inferiore in cristallo trasparente temperato 8mm o retroverniciato nei colori del campionario nella versione brillante o satinata. Struttura in acciaio inox lucido. Su richiesta struttura in ottone satinato.

Coffee table with 8mm transparent tempered glass top and 8mm transparent or painted tempered glass bottom as per samples in the bright or satin version. Bright stainless steel structure. On request, satin brass structure.



	Cm	Inches
F01	125 x 125 x 27	49¼" x 49¼" x 10¾"
F02	50 x 125 x 27	19¾" x 49¼" x 10¾"
F02	77 x 125 x 27	30½" x 49¼" x 10¾"
F03	80 x 80 x 27	31½" x 31½" x 10¾"
F03	100 x 100 x 27	39½" x 39½" x 10¾"
F03	125 x 125 x 27	49¼" x 49¼" x 10¾"

For technical drawing / p. 309

Pricelist 2023 / p. 129

▲ FARADAY
Piano superiore in cristallo trasparente / Piano inferiore in cristallo retroverniciato nero satinato / Struttura in acciaio inox lucido
Transparent glass top/ Black satin glass bottom / Bright stainless steel structure

STRUTTURA/STRUCTURE



Acciaio inox lucido
Bright stainless steel



Ottone satinato
Satin brass

PIANO SUPERIORE/TOP



Cristallo trasparente
Transparent glass

PIANO INFERIORE/BOTTOM

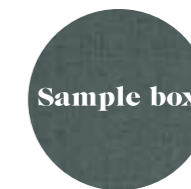

Sample box

Cristallo brillante/satinato
nei colori del campionario
Glass bright/satin version
as per samples

George 1

Pierangelo Gallotti / 1975

Mobile carrello in cristallo trasparente, extralight o "grigio Italia" temperato 8mm. Disponibile con o senza mensola. Parti metalliche in acciaio inox lucido. A richiesta acciaio inox satinato, ottone lucido, satinato o laccato bianco o nero goffrato. Disponibile versione senza ruote (altezza finita: 34cm).

! Nella versione acciaio inox lucido le ruote sono nere con copriuota cromato. Nelle altre versioni disponibili le ruote sono completamente nere.

Coffee table on castors in 8mm transparent, extralight or smoked "grigio Italia" tempered glass. Available with or without shelf. Bright stainless steel metal parts. Satin stainless steel, bright, satin or embossed white or black lacquered brass metal parts on request. Available version without castors (total height: 34cm).

! In the bright stainless steel version the castors are black with chrome castors cover. In the other available versions the castors are completely black.

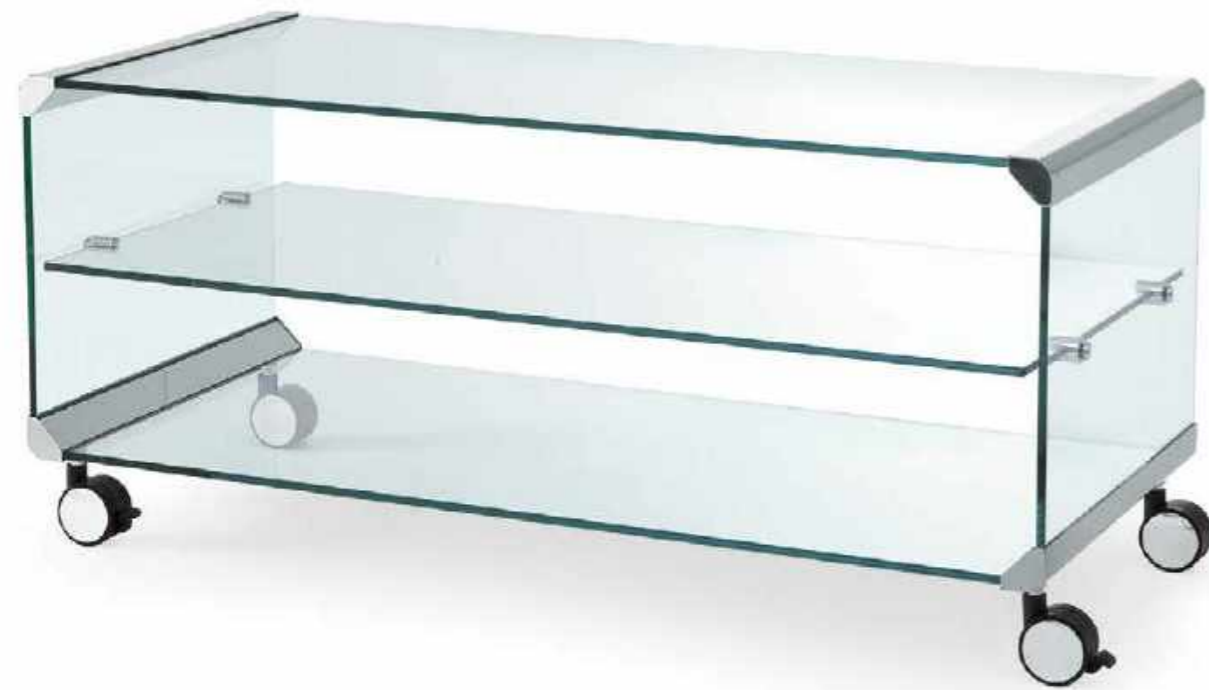

Cm

45 x 40 x 48*
68 x 40 x 48*
80 x 40 x 48*
45 x 40 x 48
68 x 40 x 48
80 x 40 x 48
100 x 45 x 45
120 x 45 x 45
130 x 45 x 45
130 x 54 x 45

* senza mensola

Inches

17¾" x 15¾" x 19**
27" x 15¾" x 19**
31½" x 15¾" x 19**
17¾" x 15¾" x 19"
27½" x 15¾" x 19"
31½" x 15¾" x 19"
39½" x 17¾" x 17¾"
47¼" x 17¾" x 17¾"
51¼" x 17¾" x 17¾"
51¼" x 21½" x 17¾"

* without shelf

For technical drawing / p. 309

Pricelist 2023 / p. 131

PIANO/TOP



Cristallo trasparente
Transparent glass



Cristallo "grigio Italia"
Smoked "grigio Italia" glass



Cristallo extralight
Extralight glass

PARTI METALLICHE/METAL PARTS



Acciaio inox lucido
Bright stainless steel

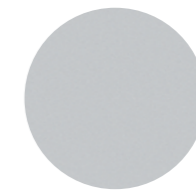

Acciaio inox satinato
Satin stainless steel

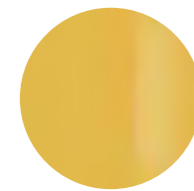

Ottone lucido
Bright brass



Ottone satinato
Satin brass



Laccato bianco goffrato
Embossed white lacquered

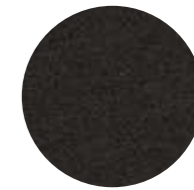

Laccato nero goffrato
Embossed black lacquered

George 2

Pierangelo Gallotti / 1975

Tavolino con ruote in cristallo trasparente, extralight o "grigio Italia" temperato 8mm. Parti metalliche in acciaio inox lucido. A richiesta acciaio inox satinato, ottone lucido, satinato o laccato bianco o nero goffrato. Disponibile versione senza ruote (altezza finita: 34cm).

Coffee table on castors in 8mm transparent, extralight or smoked "grigio Italia" tempered glass. Bright stainless steel metal parts. Satin stainless steel, bright, satin or embossed white or black lacquered brass metal parts on request. Available version without castors (total height: 34cm).

! Nella versione acciaio inox lucido le ruote sono nere con copriuota cromato.
! Nelle altre versioni disponibili le ruote sono completamente nere.

! In the bright stainless steel version the castors are black with chrome castors cover.
! In the other available versions the castors are completely black.

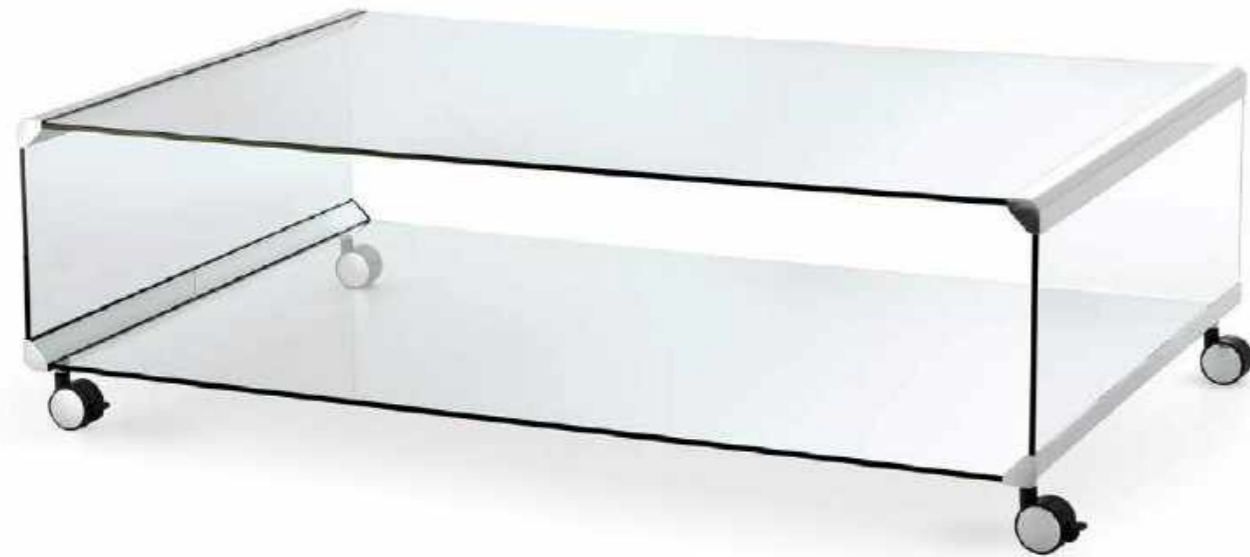

Cm

80 x 80 x 42
100 x 54 x 42
130 x 54 x 42
140 x 80 x 42

Inches

31½" x 31½" x 16¾"
39½" x 21½" x 16¾"
51¼" x 21½" x 16¾"
55¼" x 31½" x 16¾"

For technical drawing / p. 310

Pricelist 2023 / p. 133

PIANO/TOP



Cristallo trasparente
Transparent glass



Cristallo "grigio Italia"
Smoked "grigio Italia" glass



Cristallo extralight
Extralight glass

PARTI METALLICHE/METAL PARTS



Acciaio inox lucido
Bright stainless steel

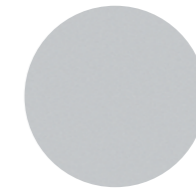

Acciaio inox satinato
Satin stainless steel

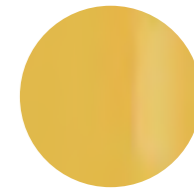

Ottone lucido
Bright brass



Ottone satinato
Satin brass



Laccato bianco goffrato
Embossed white lacquered



Laccato nero goffrato
Embossed black lacquered



Golden Moon

Massimo Castagna / 2015

Tavolino con piano in cristallo extralight temperato 12mm oppure retroverniciato nei colori del campionario, nella versione brillante o satinata. Disponibile anche con piano in cristallo "grigio Italia". Piatto in ottone lucido. Struttura in ottone brunito a mano. L'ottone risulta naturalmente macchiato e disomogeneo. Questa lavorazione artigianale conferisce ad ogni pezzo una particolare unicità, rendendolo esclusivo. Su richiesta versione senza piatto in ottone lucido.

! La ciotola è in ottone lucido naturale non protetto, per mantenere nel tempo la lucentezza del piatto in ottone, si consiglia di utilizzare prodotti specifici.

NOTE TECNICHE SUI MATERIALI

OTTONE BRUNITO A MANO | L'ottone brunito a mano è ottenuto da un processo di ossidazione naturale eseguito manualmente. Il risultato di questa lavorazione è un prodotto che può presentare macchie e variazioni di colore che non sono da considerarsi imperfezioni ma caratteristiche che conferiscono ad ogni pezzo una particolare unicità, rendendolo esclusivo.

Coffee table with 12mm extralight tempered glass top or painted glass as per samples in the bright or satin version. Also available with smoked "grigio Italia" glass top. Bright brass plate. Structure in hand burnished brass. The hand burnished brass finish looks naturally spotted and irregular. Due to this craftmade processing, each product is unique and exclusive. On request, version without bright brass plate.

! The plate is in bright natural brass not protected, in order to maintain the brightness of the brass plate, we suggest to use specific product.

TECHNICAL INFORMATION ON THE MATERIALS

HAND BURNISHED BRASS | The hand burnished brass is the consequence of hand-made process of natural oxidation. The result of this processing is a product that may show marks and colour variations. These differences are inevitable and should not be considered imperfections but distinctive features due to this craftmade processing, each product is unique and exclusive.



Cm

100 x 60 x 35
100 x 100 x 35
130 x 70 x 35

Inches

39½" x 23¾" x 14"
39½" x 39½" x 14"
51¼" x 27¾" x 14"

For technical drawing / p. 310

Pricelist 2023 / p. 134

PIANO/TOP



Cristallo extralight
Extralight glass



Cristallo brillante/satinato
nei colori del campionario
Glass bright/satin version
as per samples



Cristallo "grigio Italia"
"Grigio Italia" glass

PIATTO/PLATE

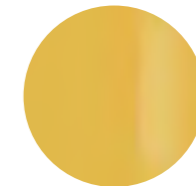

Ottone lucido
Bright brass



Ottone brunito a mano
Hand burnished brass

STRUTTURA/STRUCTURE



▲ GONG
Piano in legno bisellato "Autumn Weave"
"Autumn Weave" wooden bevelled top

Gong

Studio G&R / 2017

Tavolino in legno bisellato e decorato con lavorazione manuale ed esclusiva, disponibile nella versione "Autumn Weave" su base foglia oro oppure "Carbon Black" su base foglia rame. Zoccolo in legno rivestito foglia oro. Disponibile anche versione "Winter Weave" su base foglia argento con zoccolo in legno rivestito in foglia argento.

NOTE TECNICHE SUI MATERIALI

FINITURE ARTIGIANALI | Le finiture manuali ed esclusive risultato del processo di ossidazione di foglia argento, oro e rame possono presentare macchie e striature, oltre a differenze cromatiche. Tali disomogeneità sono caratteristiche che non devono essere considerate difetti ma elementi distintivi, tipici dell'ossidazione manuale, che esaltano la bellezza e la peculiarità del pezzo unico.

Wooden coffee table bevelled and decorated by hand with an exclusive treatment, available in "Autumn Weave" version on gold leaf base or "Carbon Black" version on copper leaf base. Wooden plinth covered by gold leaf. Also available version "Winter Weave" on silver leaf base with wooden plinth covered by silver leaf.

TECHNICAL INFORMATION ON THE MATERIALS

ARTISANAL FINISHES | Artisanal and exclusive finishes that are obtained from the oxidation of silver, gold and copper leaves may show marks and spots, as well as variations in colour. These differences are inevitable and should not be considered imperfections but evidence of the hand-crafted process. They enhance the beauty and distinctiveness of a unique piece.



	Cm	Inches
S	Ø45 x 40	17¾" x 15¾"
M	Ø70 x 31	27¾" x 12¼"
L	Ø90 x 23	35½" x 9¼"

[For technical drawing / p. 310](#)

[Pricelist 2023 / p. 135](#)
[Homescapes, sense of materials / p. 8](#)
[Homescapes, gentle attitude / pp. 21, 24, 25](#)

PIANO/TOP

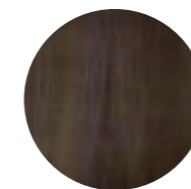

"Autumn Weave"



"Carbon black"



"Winter Weave"

BASE/BASE



Foglia oro
Gold leaf



"Winter Weave"

Haumea

Massimo Castagna / 2015

Tavolino con piano in cristallo temperato extralight 10mm. Su richiesta piano in cristallo temperato "grigio Italia" 10mm. Base in frassino tinto nero poro aperto, bianco poro aperto o laccato ruggine. Cilindro centrale in metallo ottonato lucido, brunito a mano, ramato, cromato nero, laccato bianco o nichelato lucido. Ciotola disponibile in ottone lucido, ottone cromato nero, ottone nichelato lucido o ottone laccato bianco. Disponibile nelle combinazioni sotto elencate.

NOTE TECNICHE SUI MATERIALI

OTTONE BRUNITO A MANO | L'ottone brunito a mano è ottenuto da un processo di ossidazione naturale eseguito manualmente. Il risultato di questa lavorazione è un prodotto che può presentare macchie e variazioni di colore che non sono da considerarsi imperfezioni ma caratteristiche che conferiscono ad ogni pezzo una particolare unicità, rendendolo esclusivo.

! Per versione XS e S: sconsigliato posizionamento su tappeto.

Coffee table with 10mm extralight tempered glass top. 10mm tempered smoked "grigio Italia" glass, on request. Black or white open pore stained ash or rust lacquered wooden base. Central cylinder in bright brass-plated, hand burnished, copper-plated, black chromed, white lacquered or bright nickel-plated metal. Bowl available in bright brass, black chromed brass, bright nickel-plated brass or white lacquered brass. Available in the combinations as per our list below.

TECHNICAL INFORMATION ON THE MATERIALS

HAND BURNISHED BRASS | The hand burnished brass is the consequence of hand-made process of natural oxidation. The result of this processing is a product that may show marks and colour variations. These differences are inevitable and should not be considered imperfections but evidence of the hand-crafted process. They enhance the beauty and distinctiveness of a unique piece.

! For XS and S versions: not recommended for positioning on carpet.





For technical drawing / p. 311

Pricelist 2023 / p. 136
Homescapes, sense of materials / p. 9
Homescapes, embracing beauty / p. 25
Homescapes, gentle attitude / pp. 73, 76, 78, 103

	Cm	Inches
XS	Ø50 x 48	Ø19¾" x 19"
S	Ø50 x 56	Ø19¾" x 22¼"
M	Ø80 x 40	Ø31½" x 15¾"
L	Ø120 x 33	Ø47¼" x 13"

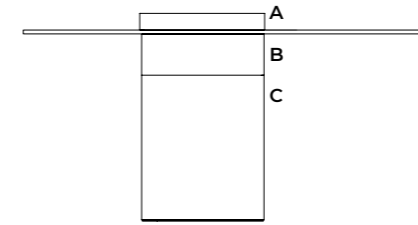
COMBINAZIONI COMBINATIONS

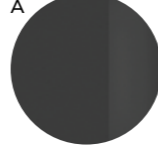

COMB.	A	B	C	PIANO/TOP
COMB. 1	 Ottone lucido Bright brass	 Ottone brunito Burnished brass	 Frassino tinto nero poro aperto Black open pore stained ash	 Cristallo extralight Extralight glass
COMB. 2	 Ottone lucido Bright brass	 Ottone lucido Bright brass	 Ruggine Rust	 Cristallo extralight Extralight glass
COMB. 3	 Ottone cromato nero Black chromed brass	 Ottone cromato nero Black chromed brass	 Frassino tinto nero poro aperto Black open pore stained ash	 Cristallo extralight Extralight glass
COMB. 4	 Ottone cromato nero Black chromed brass	 Ottone ramato Coppered brass	 Ruggine Rust	 Cristallo extralight Extralight glass
COMB. 5	 Ottone cromato nero Black chromed brass	 Ottone brunito Burnished brass	 Ruggine Rust	 Cristallo extralight Extralight glass
COMB. 6	 Ottone cromato nero Black chromed brass	 Ottone brunito Burnished brass	 Frassino tinto nero poro aperto Black open pore stained ash	 Cristallo extralight Extralight glass
COMB. 7	 Ottone nichelato lucido Bright nickel-plated brass	 Metallo nichelato lucido Bright nickel-plated metal	 Bianco poro aperto White open pore	 Cristallo extralight Extralight glass
COMB. 8	 Ottone laccato bianco opaco Mat white lacquered brass	 Metallo laccato bianco lucido Glossy white lacquered metal	 Bianco poro aperto White open pore	 Cristallo extralight Extralight glass



• HAUMEA
Combinazione 1: Piano in cristallo trasparente temperato / Base in frassino tinto nero poro aperto / Ottone brunito / Vassoio in ottone lucido
Combination 1: Transparent tempered glass top / Black open pore stained ash base / Burnished brass / Bright brass tray



• HAUMEA
Combinazione 7: Piano in cristallo trasparente temperato / Base in frassino tinto bianco poro aperto / Metallo nichelato lucido / Vassoio in ottone nichelato lucido
Combination 7: Transparent tempered glass top / White open pore stained ash base / Bright nickel-plated metal / Bright nickel-plated brass



• HAUMEA
Combinazione 8: Piano in cristallo trasparente temperato / Base in frassino tinto bianco poro aperto / Metallo laccato bianco lucido / Vassoio in ottone laccato bianco opaco
Combination 8: Transparent tempered glass top / White open pore stained ash base / Glossy white lacquered metal / Mat white lacquered brass

Monete

Massimo Castagna / 2021

Tavolino in metallo brunito a mano. Il metallo risulta naturalmente macchiato e disomogeneo. Questa lavorazione artigianale conferisce ad ogni pezzo una particolare unicità, rendendolo esclusivo. Disponibile anche versione in metallo laccato lucido nei colori "oxide red" (RAL 3009) o "black green" (RAL 6012).

NOTE TECNICHE SUI MATERIALI

METALLO BRUNITO A MANO | La finitura artigianale metallo brunito a mano è ottenuta manualmente da un processo di acidatura in grado di conferire particolari effetti cromatici dalle diverse tonalità che variano dal marrone scuro al grigio. Una volta fermato il processo di acidatura, il tavolino viene coperto con una vernice protettiva.

Coffee table in hand burnished metal. The metal looks naturally spotted and irregular. Due to this craftmade processing, each product is unique and exclusive. Also available glossy lacquered metal version in the colours "oxide red" (RAL 3009) or "black green" (RAL 6012).

TECHNICAL INFORMATION ON THE MATERIALS

HAND BURNISHED METAL | The handcrafted finish hand burnished metal is the consequence of hand-made process of acid etching which gives particular chromatic effects of different tonalities that goes from dark brown to grey. Once the etching process has stopped the coffee table is covered by protective varnish.



• **MONETE**
Versione A: Metallo brunito a mano
Version A: hand burnished brass



	Cm	Inches
A	47 x 48 x 52	18¾" x 19" x 20½"
B	52 x 55 x 47	20½" x 21¾" x 18¾"

[For technical drawing / p. 311](#)

[Pricelist 2023 / p. 138](#)
[Homescapes, intimate portraits / pp. 64, 70](#)
[Homescapes, gentle attitude / pp. 21, 24](#)

STRUTTURA/STRUCTURE



Metallo brunito a mano
Hand burnished metal

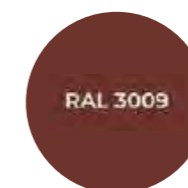

Metallo laccato lucido "oxide red" (RAL 3009)
Glossy lacquered metal
"oxide red" (RAL 3009)

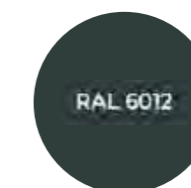

Metallo laccato lucido "black green" (RAL 6012)
Glossy lacquered metal
"black green" (RAL 6012)

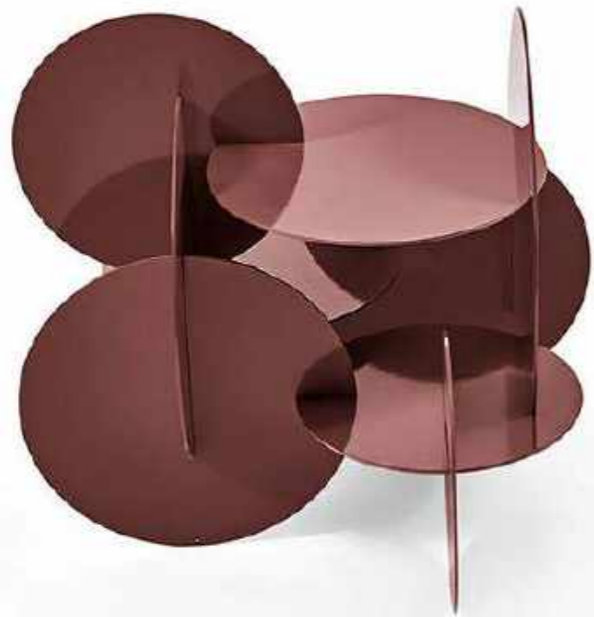

• **MONETE**
Metallo laccato lucido "oxide red" (RAL 3009)
Glossy lacquered metal "oxide red" (RAL 3009)



• **MONETE**
Metallo laccato lucido "black green" (RAL 6012)
Glossy lacquered metal "black green" (RAL 6012)

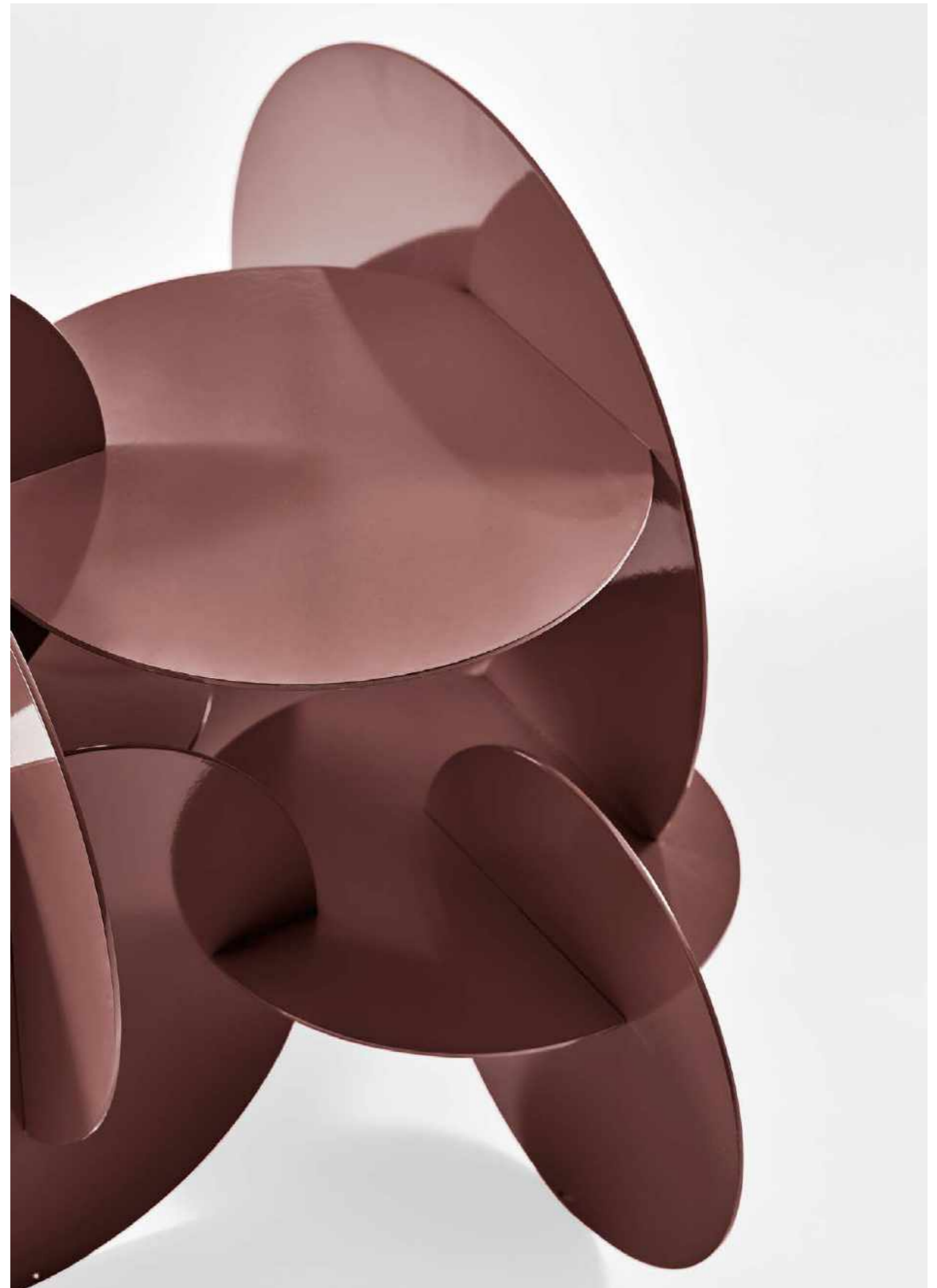

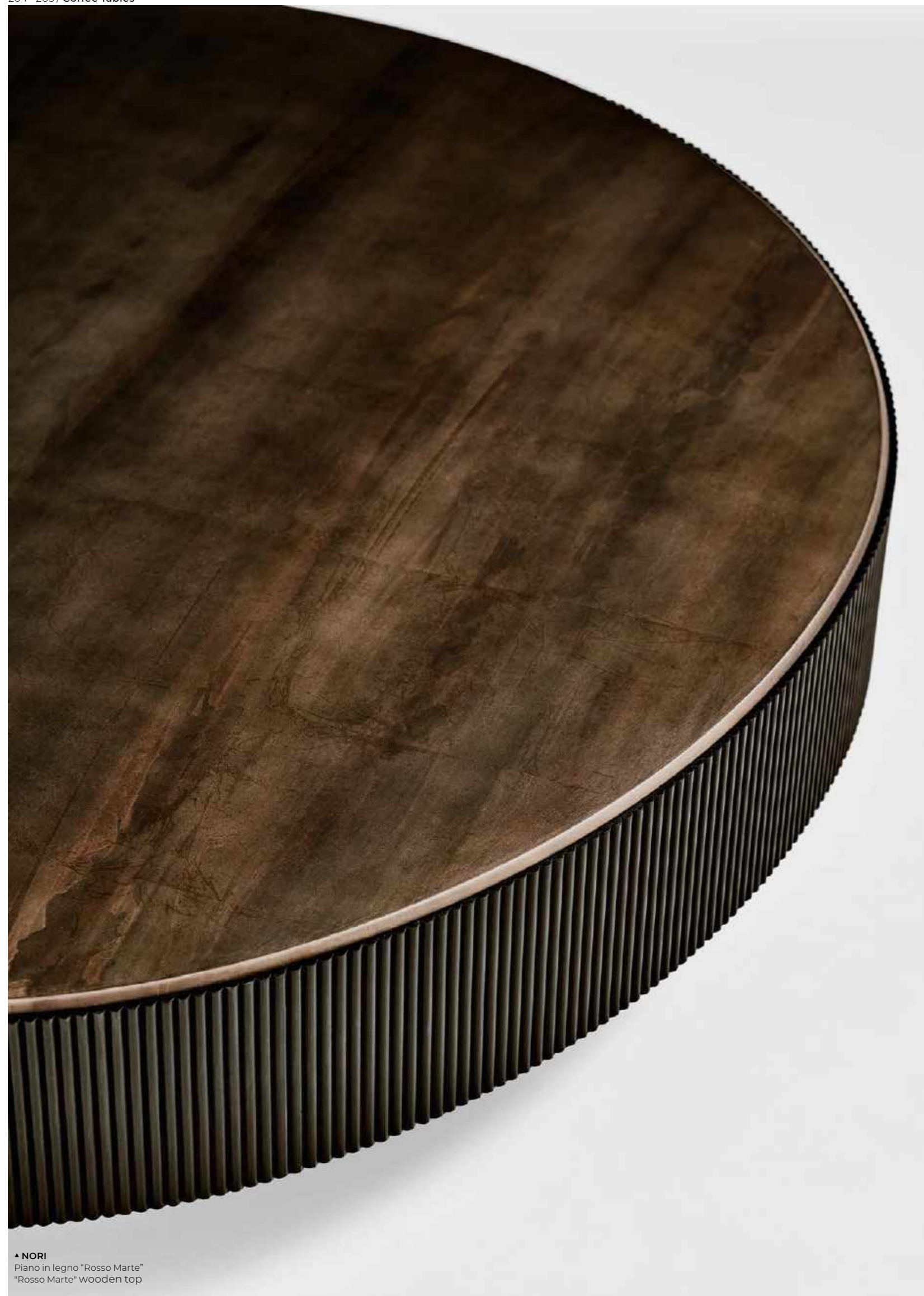

▲ NORI
Piano in legno "Rosso Marte"
"Rosso Marte" wooden top

Nori

Studio G&R / 2018

Tavolino in legno massello tinto nero, rivestito con fascia zigrinata a mano. Piano in pelle Fard nei colori del campionario. Disponibile versione con piano in marmo nelle finiture lucido naturale Calacatta Vagli Oro, Verde Alpi, spazzolato Fior di Pesco oppure versione con piano in legno "Rosso Marte" oppure verniciato nella finitura esclusiva bronzo antico e piombo oppure verniciato con finitura esclusiva spazzolata "Cashmere" gold grey o anthracite. Zoccolo in ottone brunito a mano oppure ottone brunito scuro, da definire al momento dell'ordine.

NOTE TECNICHE SUI MATERIALI

PELLE FARD | Tutto il vissuto del manto resta completamente visibile e si manifesta in venature, graffi, possibili variazioni cromatiche, naturali arricciature, che conferiscono a questa pelle una preziosità unica.

MARMO | Il marmo è un materiale naturale di origine sedimentaria che può presentare particolarità come venature, lievi irregolarità superficiali, colorazioni differenti e cristallizzazioni. Queste peculiarità sono da attribuirsi alla naturalezza del materiale e non sono da considerarsi difetti ma caratteristiche tipiche del marmo. Ogni prodotto risulterà unico, esclusivo e non replicabile. I nostri marmi vengono trattati con un prodotto idrorepellente che permette una maggiore protezione della superficie stessa, aumentando l'impermeabilità. Questo trattamento non esclude la vulnerabilità del marmo alle sostanze acide.

FINITURE ESCLUSIVE | Le finiture esclusive risultano dalla lavorazione manuale possono presentare striature e differenze cromatiche. Queste caratteristiche non devono essere considerate difetti ma elementi distintivi del processo artigianale che esaltano la bellezza e la peculiarità del pezzo unico.

OTTONE BRUNITO A MANO | L'ottone brunito a mano è ottenuto da un processo di ossidazione naturale eseguito manualmente. Il risultato di questa lavorazione è un prodotto che può presentare macchie e variazioni di colore che non sono da considerarsi imperfezioni ma caratteristiche che conferiscono ad ogni pezzo una particolare unicità, rendendolo esclusivo.

Coffee table in black stained solid wood, covered by hand-knurled border part. Fard leather top available as per sample. Also available version with marble top in natural polished Calacatta Vagli Oro, Verde Alpi or brushed Fior di Pesco or with wooden top "Rosso Marte" or painted with the exclusive antique bronze and lead finish or with the exclusive "Cashmere" brushed finish in the colours gold grey or anthracite. Hand burnished or dark burnished brass plinth, to be specified when ordering.

TECHNICAL INFORMATION ON THE MATERIALS

FARD LEATHER | The layer's past is fully visible and is expressed in the grain, possible colour variations, and natural crimping, which give this leather a unique precious feel.

MARBLE | The marble is a natural material of sedimentary origin that can present particularities such as veins, slight surface irregularities, different colors and crystallizations. These peculiarities are to be attributed to the naturalness of the material and are not to be considered defects but typical characteristics of marble. Each product will be unique, exclusive and non-replicable. Our marbles are treated with water-repellent products which affords greater protection to the surface of the marble, improving its impermeability. This treatment doesn't exclude the vulnerability of the marble to acid substances.

EXCLUSIVE FINISHES | Exclusive finishes, resulting from the craftsmanship, may show streaks and chromatic differences. These characteristics should not be considered imperfections but distinctive evidence of the hand-made process that enhance the beauty and peculiarity of the unique piece.

HAND BURNISHED BRASS | The hand burnished brass is the consequence of hand-made process of natural oxidation. The result of this processing is a product that may show marks and colour variations. These differences are inevitable and should not be considered imperfections but distinctive features due to this craftmade processing, each product is unique and exclusive.



	Cm	Inches
S	50,5 x 53 x 38,5	20" x 21" x 15¼"
M	68 x 71 x 33,5	27" x 28" x 13¼"
L	87 x 91 x 28,5	34½" x 36" x 11¼"
XL	101 x 106 x 23,5	40" x 41¾" x 9½"

For technical drawing / p. 311

Pricelist 2023 / p. 139
Homescapes, embracing beauty / p. 25
Homescapes, intimate portraits / pp. 17, 23
Homescapes, gentle attitude / pp. 52, 53, 92, 93

PIANO/TOP



Pelle fard
nei colori del campionario
Fard leather as per samples



Marmo lucido naturale
Calacatta Vagli Oro
Natural polished
Calacatta Vagli Oro marble

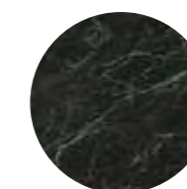

Marmo lucido naturale
Verde Alpi
Natural polished
Verde Alpi marble



Marmo spazzolato
Fior di Pesco
Brushed Fior di Pesco
marble



Legno verniciato
Bronzo antico / Piombo
Wood painted
Antique bronze / Lead

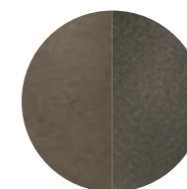

Legno verniciato
Bronzo antico / Piombo
Wood painted
Antique bronze / Lead



Legno spazzolato
"Cashmere" Gold Grey
"Cashmere" Gold Grey
brushed wood



Legno spazzolato
"Cashmere" Anthracite
"Cashmere" Anthracite
brushed wood

STRUTTURA/STRUCTURE



Legno tinto nero poro
aperto / Ottone brunito a
mano
Black open pore stained
wood / Hand burnished
brass



▲ NOX
Piani in cristallo trasparente / Struttura in acciaio inox lucido / Parti in legno rovere tinto wengé
Transparent glass top / Stainless steel structure / Wengé stained wooden parts

Nox

Ricardo Bello Dias / 2009

Tavolino in cristallo temperato 8mm. Piano superiore in cristallo trasparente. Piano inferiore in cristallo retroverniciato nei colori del campionario nella versione brillante o satinata. Struttura in acciaio inox o in metallo laccato color brunito con parti in legno in rovere sbiancato, tinto wengé, tinto tabacco o laccato nero poro aperto.

Coffee table in 8mm tempered glass. Transparent glass top. Painted glass bottom as per samples in the bright or satin version. Stainless steel or burnished lacquered metal structure with whitened oak, wengé stained, tobacco stained or black open pore lacquered wooden parts.



Cm

80 x 60 x 30
80 x 80 x 30
100 x 60 x 30
100 x 80 x 30
100 x 100 x 30
60 x 60 x 50
80 x 60 x 50
80 x 80 x 50
120 x 120 x 30
80 x 140 x 30
60 x 160 x 30

Inches

31½" x 23¾" x 12"
31½" x 31½" x 12"
39½" x 23¾" x 12"
39½" x 31½" x 12"
39½" x 39½" x 12"
23¾" x 23¾" x 19¾"
31½" x 23¾" x 19¾"
31½" x 31½" x 19¾"
47¼" x 47¼" x 12"
31½" x 55¼" x 12"
23¾" x 63" x 12"

For technical drawing / p. 312

Pricelist 2023 / p. 140

PIANO SUPERIORE/TOP



Cristallo trasparente
Transparent glass

PIANO INFERIORE/BOTTOM

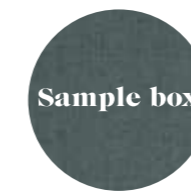

Cristallo brillante/satinato
nei colori del campionario
Glass bright/satin version
as per samples

STRUTTURA/STRUCTURE



Acciaio inox
Stainless steel

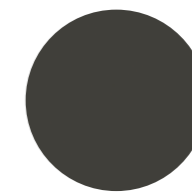

Metallo laccato color
brunito
Burnished lacquered metal

PARTI IN LEGNO/WOODEN PARTS



Rovere sbiancato
Whitened oak



Rovere tinto wengé
Wengé stained oak

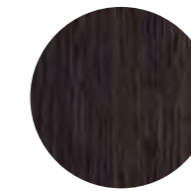

Rovere tinto tabacco
Tobacco stained oak

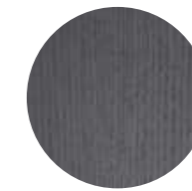

Rovere laccato nero poro aperto
Black open pore lacquered oak

Oto Mini

Oscar e Gabriele Buratti / 2015

Tavolino con piano in cristallo bisellato (25mm) e retroverniciato nei colori nero, blu grigio e liquirizia nella versione brillante o satinata. Struttura in metallo verniciato lucido. Disponibile anche nella versione con piano in cristallo e struttura in metallo verniciati bronzo patinato.

Coffee table with bevelled (25mm) and painted glass top in the colours black, blue grey and liquorice in the bright or satin version. Bright lacquered metal structure. Also available with patinated bronze painted glass top and metal structure.

NOTE TECNICHE SUI MATERIALI

CRISTALLO | Le finiture esclusive risultato della lavorazione manuale realizzata sul cristallo possono presentare striature e differenze cromatiche. Queste caratteristiche non devono essere considerate difetti ma elementi distintivi del processo artigianale che esaltano la bellezza e la peculiarità del pezzo unico.

TECHNICAL INFORMATION ON THE MATERIALS

GLASS | Exclusive finishes, resulting from the craftsmanship on the glass, may show streaks and chromatic differences. These characteristics should not be considered imperfections but distinctive evidence of the hand-made process that enhance the beauty and peculiarity of the unique piece



Cm

Spessore 10mm
Ø45 x 50

Spessore 15mm
Ø90 x 32
Ø90 x 42
Ø100 x 32
Ø100 x 42
Ø120 x 32
Ø120 x 42
Ø130 x 32
Ø130 x 42

Inches

Thickness 10mm
Ø17¾" x 19¾"

Thickness 15mm
Ø35½" x 12¾"
Ø35½" x 16¾"
Ø39½" x 12¾"
Ø39½" x 16¾"
Ø47¼" x 12¾"
Ø47¼" x 16¾"
Ø51¼" x 12¾"
Ø51¼" x 16¾"

For technical drawing / p. 312

Pricelist 2023 / p. 142
Homescapes, intimate portraits / p. 107

PIANO E STRUTTURA/TOP AND STRUCTURE

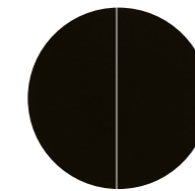

**Cristallo retroverniciato
nero brillante/satinato**
Bright/satin black
painted glass

**Metallo verniciato
nero lucido**
Bright black
lacquered metal

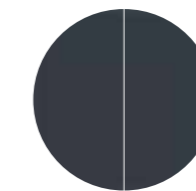

**Cristallo retroverniciato
blu grigio brillante/satinato**
Bright/satin blue grey
painted glass

**Metallo verniciato
blu grigio lucido**
Bright blue grey
lacquered metal

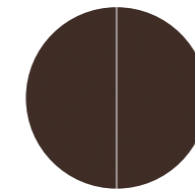

**Cristallo retroverniciato
liquirizia brillante/satinato**
Bright/satin liquorice
painted glass

**Metallo verniciato
liquirizia lucido**
Bright liquorice
lacquered metal

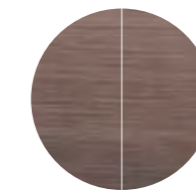

**Cristallo verniciato
bronzo patinato**
Patinated bronze
painted glass

**Metallo verniciato
bronzo patinato**
Patinated bronze
lacquered metal

▲ OTO MINI

Piano in cristallo bisellato e retroverniciato blu-grigio brillante / Struttura in metallo blu-grigio lucido
Bevelled and bright blue-grey painted glass top / Blue-grey bright lacquered metal structure

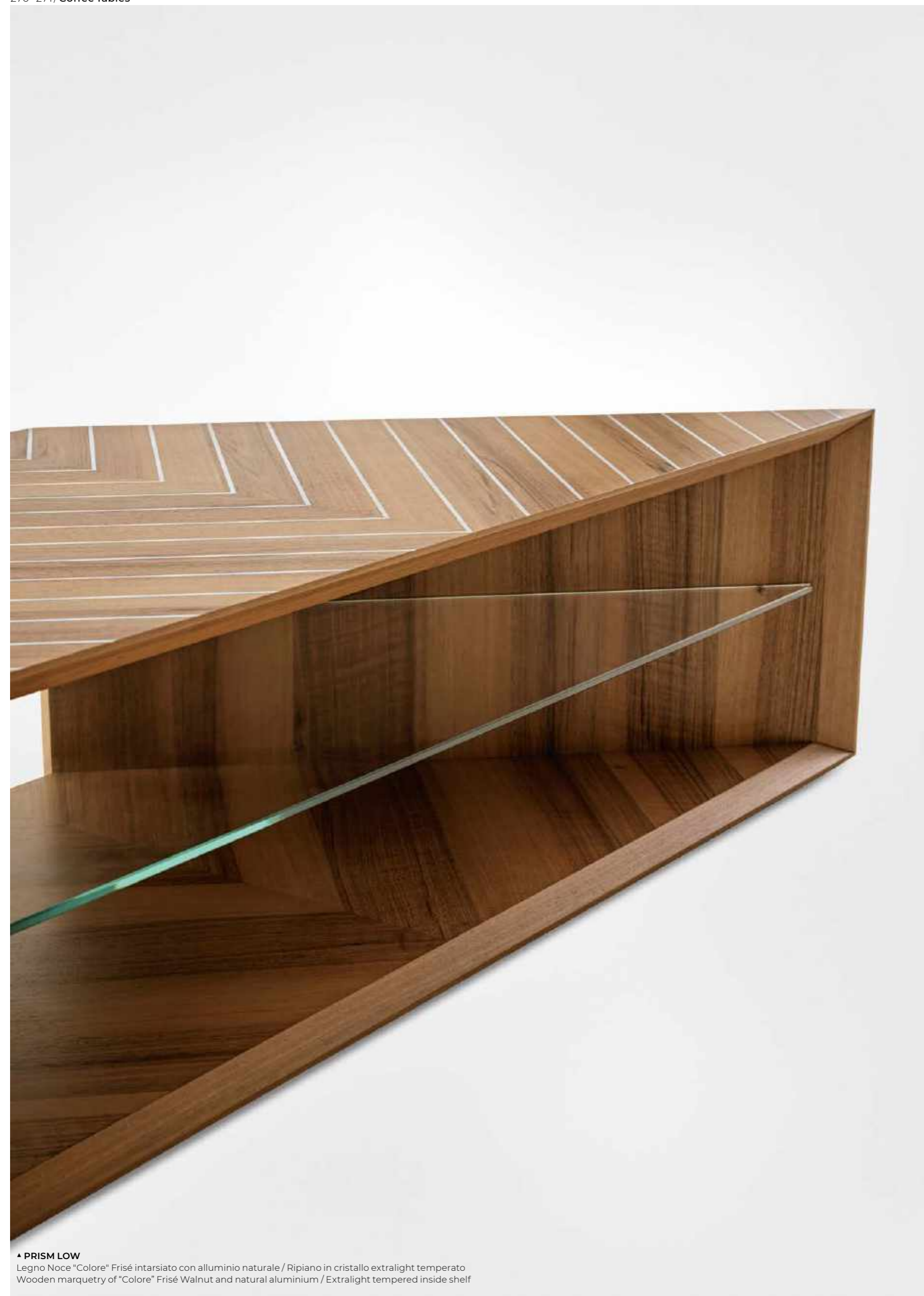

▲ **PRISM LOW**
 Legno Noce "Colore" Frisé intarsiato con alluminio naturale / Ripiano in cristallo extralight temperato
 Wooden marquetry of "Colore" Frisé Walnut and natural aluminium / Extralight tempered inside shelf

Prism Low

david/nicolas / 2020

Tavolino in legno Noce "Colore" Frisé intarsiato con alluminio naturale o Palissandro India intarsiato con alluminio naturale. Versione h.37 cm dotata di ripiano interno in cristallo extralight temperato 8 mm. Versione h. 23/31/40/47 cm disponibile sia in Travertino Romano spazzolato naturale (non resinato) che in marmo Verde Alpi lucido naturale.

! Il legno è un materiale vivo che subisce un naturale processo di ossidazione che può causare cambiamenti cromatici. Venature e tonalità di colore differenti delle lastre non sono da considerarsi come difetti, ma caratteristiche che esaltano l'unicità del materiale.

NOTE TECNICHE SUI MATERIALI

INTARSIO | L'intarsio è una tecnica di lavorazione artigianale utilizzata per ottenere un particolare disegno e si realizza accostando elementi di materiali differenti (come legno e alluminio) oppure dello stesso materiale. Questa lavorazione rende il prodotto unico ed esclusivo. Le eventuali variazioni cromatiche e di venatura del legno sono da considerarsi caratteristiche del materiale stesso e non possono essere controllate.

TRAVERTINO/MARMO | Il marmo è un materiale naturale di origine sedimentaria che può presentare particolarità come venature, lievi irregolarità superficiali, colorazioni differenti e cristallizzazioni. Queste peculiarità sono da attribuirsi alla naturalezza del materiale e non sono da considerarsi difetti ma caratteristiche tipiche del marmo. Ogni prodotto risulterà unico, esclusivo e non replicabile.

I nostri marmi (escluso il Travertino Romano) vengono trattati con un prodotto idrorepellente che permette una maggiore protezione della superficie stessa, aumentando l'impermeabilità. Questo trattamento non esclude la vulnerabilità del marmo alle sostanze acide.

Wooden coffee table with marquetry of "Colore" Frisé Walnut and natural aluminium or India Rosewood and natural aluminium. 37 cm h. version supplied with 8 mm thick extralight tempered inside shelf. 23/31/40/47 cm h. version available in either natural brushed Travertino Romano (not treated with resin) or natural polish Verde Alpi marble.

! Wood is a living material and the natural oxidation process can cause chromatic changes. Different grain and colour shades of the wooden slabs are not to be considered as defects, but characteristics that enhance the uniqueness of the material.

TECHNICAL INFORMATION ON THE MATERIALS

INLAY | Inlay is an artisanal technique used to obtain a particular design and is made by combining elements of different materials (such as wood and aluminium) or of the same material. This process makes the product unique and exclusive. Any colour and grain variations of the wood are to be considered as characteristics of the material itself and cannot be controlled.

TRAVERTINO/MARBLE | The marble is a natural material of sedimentary origin that can present particularities such as veins, slight surface irregularities, different colors and crystallizations. These peculiarities are to be attributed to the naturalness of the material and are not to be considered defects but typical characteristics of marble. Each product will be unique, exclusive and non-replicable.

Our marbles (excluded Travertino Romano) are treated with water-repellent products which affords greater protection to the surface of the marble, improving its impermeability.

This treatment doesn't exclude the vulnerability of the marble to acid substances.



Cm

Marmo

40 x 40 x 40

40 x 40 x 47

65 x 64 x 31

93 x 91 x 23

Legno

117,5 x 47 x 30

117,5 x 47 x 37

141,5 x 59 x 30

141,5 x 59 x 37

Inches

Marble

15¾" x 15¾" x 15¾"

15¾" x 15¾" x 18¾"

25¾" x 25¾" x 12¾"

36¾" x 36" x 9¾"

Wood

46½" x 18¾" x 12"

46½" x 18¾" x 14¾"

55¾" x 23¾" x 12"

55¾" x 23¾" x 14¾"

[For technical drawing / p. 313](#)

[Pricelist 2023 / p. 143](#)

[Homescapes, embracing beauty / p. 82](#)

[Homescapes, intimate portraits / p. 53](#)

[Homescapes, gentle attitude / pp. 48, 72, 73, 76, 79, 98, 100](#)

STRUTTURA/STRUCTURE

VERSIONE 37 CM



Legno Noce "Colore" Frisé e alluminio naturale
 "Colore" Frisé Walnut and aluminium

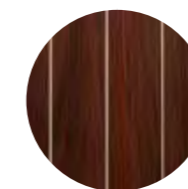

Legno palissandro India e alluminio naturale
 India rosewood and aluminium

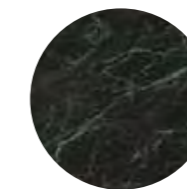

Marmo Verde Alpi lucido naturale
 Natural polish Verde Alpi marble



Travertino Romano spazzolato naturale
 Natural brushed Travertino Romano



Cristallo extralight
 Extralight glass

STRUTTURA/STRUCTURE

VERSIONE 40-47 CM

RIPIANO INTERNO/INSIDE SHELF

VERSIONE 37 CM

Raj 1

Ricardo Bello Dias / 2006

Tavolino con piano in cristallo temperato trasparente o extralight 12mm. Struttura in acciaio inox lucido (profilo 40x20x2mm). Giunto centrale in alluminio cromato. Disponibile con piano in cristallo 12mm temperato "grigio Italia" e struttura in metallo laccato color brunito.

Coffee table with 12mm tempered transparent or extralight glass top. Bright stainless steel base (40x20x2mm). Chromed aluminium central part. Also available with 12mm tempered smoked "grigio Italia" glass top and burnished lacquered metal structure.



Cm

Ø100 x 27
 Ø100 x 37
 Ø120 x 27
 Ø120 x 37
 Ø140 x 27
 Ø140 x 37

Inches

Ø39½" x 10¾"
 Ø39½" x 14¾"
 Ø47¼" x 10¾"
 Ø47¼" x 14¾"
 Ø55¼" x 10¾"
 Ø55¼" x 14¾"

For technical drawing / p. 313

Pricelist 2023 / p. 144

PIANO/TOP



Cristallo trasparente
 Transparent glass



Cristallo extralight
 Extralight glass



Cristallo "grigio Italia"
 "Grigio Italia" glass

STRUTTURA/STRUCTURE



Acciaio inox lucido
 Bright stainless steel

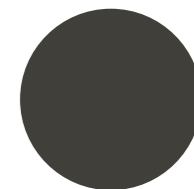

Metallo laccato color brunito
 Burnished lacquered metal

▲ RAJ1

Piano in cristallo extralight temperato / Struttura in acciaio inox lucido
 Transparent tempered glass top / Bright stainless steel base

Raj 2

Ricardo Bello Dias / 2006

Tavolino con piano in cristallo trasparente o extralight 10mm. Struttura in acciaio inox lucido (profilo 20x20x1,5mm). Giunto centrale in alluminio cromato. Disponibile con piano in cristallo "grigio Italia" 10mm e struttura in metallo laccato color brunito.

Coffee table with 10mm transparent or extralight glass top. Bright stainless steel base (20x20x1,5 mm). Chromed aluminium central part. Also available with 10mm smoked "grigio Italia" glass top and burnished lacquered metal structure.



	Cm	Inches
S	Ø40 x 40	Ø15¾" x 15¾"
M	Ø45 x 45	Ø17¾" x 17¾"
L	Ø50 x 50	Ø19¾" x 19¾"
XL	Ø70 x 33	Ø27¾" x 13"
XXL	Ø80 x 23	Ø31½" x 9¼"

For technical drawing / p. 314

Pricelist 2023 / p. 145

PIANO/TOP



Cristallo trasparente
Transparent glass



Cristallo extralight
Extralight glass



Cristallo "grigio Italia"
"Grigio Italia" glass

STRUTTURA/STRUCTURE



Acciaio inox lucido
Bright stainless steel

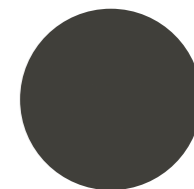

Metallo laccato color
brunito
Burnished lacquered metal

▲ RAJ 2
Piano in cristallo extralight temperato / Struttura in acciaio inox lucido
Transparent tempered glass top / Bright stainless steel base



▲ **RAJ 3**
Piano in cristallo extralight temperato / Struttura in acciaio inox lucido
Transparent tempered glass top / Bright stainless steel base

Raj 3

Ricardo Bello Dias / 2011

Tavolino con piano in cristallo temperato trasparente o extralight 8mm. Struttura in acciaio inox lucido (profilo 20x20x1,5 mm). Giunto centrale in alluminio cromato. Disponibile con piano in cristallo temperato "grigio Italia" 8mm e struttura in metallo laccato color brunito.

Coffee table with 8mm tempered transparent or extralight glass top. Bright stainless steel base (20x20x1,5mm). Chromed aluminium central part. Also available with 8mm tempered smoked "grigio Italia" glass top and burnished lacquered metal structure.



	Cm	Inches
S	69 x 44 x 40	27 ¹ / ₄ " x 17 ¹ / ₂ " x 15 ³ / ₄ "
M	86 x 56 x 33	34" x 22 ¹ / ₄ " x 13"
L	108 x 70 x 23	43 ³ / ₄ " x 27 ³ / ₄ " x 9 ¹ / ₄ "

For technical drawing / p. 314

Pricelist 2023 / p. 146

PIANO/TOP



Cristallo trasparente
Transparent glass



Cristallo extralight
Extralight glass



Cristallo "grigio Italia"
"Grigio Italia" glass

STRUTTURA/STRUCTURE



Acciaio inox lucido
Bright stainless steel

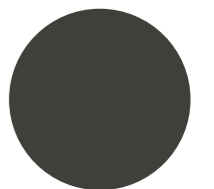

Metallo laccato color
brunito
Burnished lacquered metal

Raj 6

Ricardo Bello Dias / 2013

Tavolino con piano in cristallo temperato "grigio Italia" 10mm e struttura in metallo laccato color brunito. Disponibile con piano in cristallo temperato trasparente o extralight 10mm e struttura in acciaio inox lucido.

Coffee table with 10mm smoked "grigio Italia" tempered glass top and burnished lacquered metal structure. Also available with 10mm tempered transparent or extralight glass top and structure in bright stainless steel.



Cm

120 x 70 x 23
140 x 70 x 23
160 x 70 x 23
120 x 70 x 33
140 x 70 x 33
160 x 70 x 33
140 x 40 x 40
160 x 40 x 40
180 x 40 x 40

Inches

47 $\frac{1}{4}$ " x 27 $\frac{3}{4}$ " x 9 $\frac{1}{4}$ "
55 $\frac{1}{4}$ " x 27 $\frac{3}{4}$ " x 9 $\frac{1}{4}$ "
63" x 27 $\frac{3}{4}$ " x 9 $\frac{1}{4}$ "
47 $\frac{1}{4}$ " x 27 $\frac{3}{4}$ " x 13"
55 $\frac{1}{4}$ " x 27 $\frac{3}{4}$ " x 13"
63" x 27 $\frac{3}{4}$ " x 13"
55 $\frac{1}{4}$ " x 15 $\frac{3}{4}$ " x 15 $\frac{3}{4}$ "
63" x 15 $\frac{3}{4}$ " x 15 $\frac{3}{4}$ "
71" x 15 $\frac{3}{4}$ " x 15 $\frac{3}{4}$ "

For technical drawing / p. 314

Pricelist 2023 / p. 147

▲ RAJ 6

Piano in cristallo "grigio Italia" temperato / Struttura in metallo laccato color brunito
"Grigio Italia" tempered glass top / Burnished lacquered metal structure

PIANO/TOP



Cristallo "grigio Italia"
"Grigio Italia" glass



Cristallo trasparente
Transparent glass



Cristallo extralight
Extralight glass

STRUTTURA/STRUCTURE

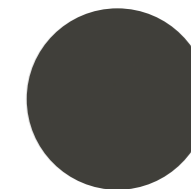

Metallo laccato color
brunito
Burnished lacquered metal



Acciaio inox lucido
Bright stainless steel



Re-verre

Federica Biasi / 2023

Tavolino monomaterico in vetro riciclato nella finitura "melange terre".

Coffee table in recycled glass in the "melange terre" finish.

NOTE TECNICHE SUI MATERIALI

FINITURE ARTIGIANALI | Trattandosi di una lavorazione artigianale e manuale le misure sono indicative e la superficie potrebbe non essere completamente planare.

TECHNICAL INFORMATION ON THE MATERIALS

ARTISANAL FINISHES | Since it is an artisanal and manual process, the measurements are indicative and the surface may not be completely flat.



Cm

Ø50 x 50
Ø60 x 47
Ø90 x 37
Ø120 x 27

Inches

Ø19¾" x 19¾"
Ø23¾" x 18¾"
Ø35½" x 14¾"
Ø47¼" x 10¾"

[For technical drawing / p. 315](#)

[Pricelist 2023 / p. 148](#)

STRUTTURA/STRUCTURE



Vetro riciclato
"melange terre"
"Melange terre"
recycled glass



Selce

Studiopepe / 2023

Tavolino in pietra. Disponibile nella finitura "Ceppo dei Volpi" o "Ceppo Antico". Su richiesta disponibile anche in Travertino Romano spazzolato naturale (non resinato). Versione destra o sinistra (A e C) da specificare al momento dell'ordine.

Coffee table in stone. Available in "Ceppo dei Volpi" or "Ceppo Antico". On request also available in natural brushed Travertino Romano (not treated with resin). Right or left version (A and C) to be specified when ordering

NOTE TECNICHE SUI MATERIALI

MARMO | Il marmo è un materiale naturale di origine sedimentaria che può presentare particolarità come venature, lievi irregolarità superficiali, colorazioni differenti e cristallizzazioni. Queste peculiarità sono da attribuirsi alla naturalezza del materiale e non sono da considerarsi difetti ma caratteristiche tipiche del marmo. Ogni prodotto risulterà unico, esclusivo e non replicabile. I nostri marmi vengono trattati con un prodotto idrorepellente che permette una maggiore protezione della superficie stessa, aumentando l'impermeabilità. Questo trattamento non esclude la vulnerabilità del marmo alle sostanze acide.

TECHNICAL INFORMATION ON THE MATERIALS

MARBLE | The marble is a natural material of sedimentary origin that can present particularities such as veins, slight surface irregularities, different colors and crystallizations. These peculiarities are to be attributed to the naturalness of the material and are not to be considered defects but typical characteristics of marble. Each product will be unique, exclusive and non-replicable. Our marbles are treated with water-repellent products which affords greater protection to the surface of the marble, improving its impermeability. This treatment doesn't exclude the vulnerability of the marble to acid substances.



Cm

A 85 x 68 x 36,4
B Ø50 x 50,4
C 136 x 70 x 30,8

Inches

A 33½" x 27" x 14½"
B Ø19¾" x 20¾"
C 53¾" x 27¾" x 12"

[For technical drawing / p. 315](#)

[Pricelist 2023 / p. 149](#)

STRUTTURA/STRUCTURE



"Ceppo dei Volpi"
"Ceppo de Volpi"



"Ceppo Antico"
"Ceppo Antico"



Travertino Romano
spazzolato naturale
Natural brushed
Travertino Romano

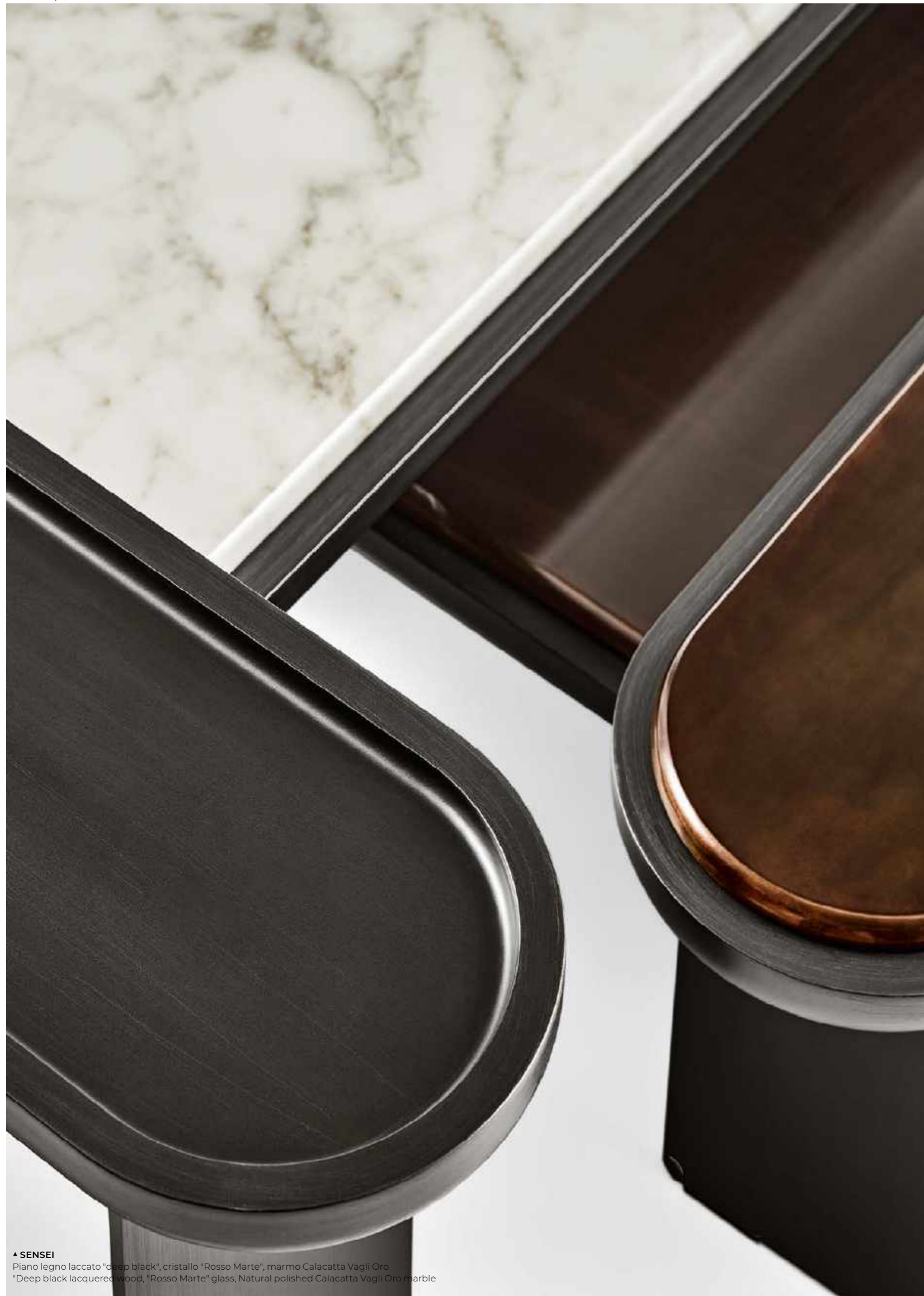

▲ SENSEI
Piano legno laccato "deep black", cristallo "Rosso Marte", marmo Calacatta Vagli Oro
"Deep black lacquered wood, "Rosso Marte" glass, Natural polished Calacatta Vagli Oro marble

Sensei

Tollgard + Castellani / 2022

Tavolino con struttura in metallo e piano in legno laccato "deep black". In appoggio sul top in legno, piano in cristallo 12mm molato a mezzo toro nella finitura esclusiva "Rosso Marte" oppure retroverniciato brillante nei colori del campionario. Disponibile anche piano in marmo 20mm Calacatta Vagli Oro lucido naturale, Ceppo di Gré® spazzolato, Arabescato Orobico Rosso satinato oppure Bianco Carrara Gioia spazzolato. Il tavolino "A" viene realizzato esclusivamente con piano in legno ribassato.

Coffee table with "deep black" lacquered metal structure and wooden top. Resting on the wooden top, 12mm glass top with half bull-nose grinding in the exclusive finish "Rosso Marte" or painted as per samples in the bright version. Also available with 20mm natural polished Calacatta Vagli Oro marble, brushed Ceppo di Gré®, satin Arabescato Orobico Rosso or brushed Bianco Carrara Gioia. The coffee table A is made exclusively with recessed wooden top.

NOTE TECNICHE SUI MATERIALI

MARMO | Il marmo è un materiale naturale di origine sedimentaria che può presentare particolarità come venature, lievi irregolarità superficiali, colorazioni differenti e cristallizzazioni. Queste peculiarità sono da attribuirsi alla naturalezza del materiale e non sono da considerarsi difetti ma caratteristiche tipiche del marmo. Ogni prodotto risulterà unico, esclusivo e non replicabile. I nostri marmi vengono trattati con un prodotto idrorepellente che permette una maggiore protezione della superficie stessa, aumentando l'impermeabilità. Questo trattamento non esclude la vulnerabilità del marmo alle sostanze acide.

TECHNICAL INFORMATION ON THE MATERIALS

MARBLE | The marble is a natural material of sedimentary origin that can present particularities such as veins, slight surface irregularities, different colors and crystallizations. These peculiarities are to be attributed to the naturalness of the material and are not to be considered defects but typical characteristics of marble. Each product will be unique, exclusive and non-replicable. Our marbles are treated with water-repellent products which affords greater protection to the surface of the marble, improving its impermeability. This treatment doesn't exclude the vulnerability of the marble to acid substances.



Cm

Piano in legno

A | 130 x 25 x 43

Piano in cristallo

B | 160 x 25 x 34,5

C | 180 x 45 x 34,5

D | 140 x 85 x 24,5

Piano in marmo

B | 160 x 25 x 35

C | 180 x 45 x 35

D | 140 x 85 x 25

Inches

Wooden top

A | 51¼" x 10" x 17"

Glass top

B | 63" x 10" x 13¾"

C | 71" x 17¾" x 13¾"

D | 55½" x 33½" x 9¾"

Marble top

B | 63" x 10" x 14"

C | 71" x 17¾" x 14"

D | 55½" x 33½" x 10"

For technical drawing / p. 316

Pricelist 2023 / p. 150

Homescapes, gentle attitude / pp. 36, 39, 72, 74

PIANO/TOP



Legno laccato "deep black"
"deep black" lacquered wood



Cristallo "Rosso Marte"
"Rosso Marte" glass

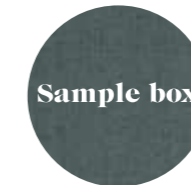

Cristallo brillante nei colori del campionario
Bright glass version as per samples



Marmo lucido naturale Calacatta Vagli Oro
Natural polished Calacatta Vagli Oro marble

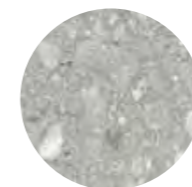

Ceppo di Gré® spazzolato
Brushed Ceppo di Gré®

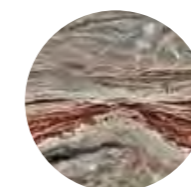

Marmo Arabescato Orobico Rosso satinato
Arabescato Orobico Rosso satin marble



Marmo spazzolato Bianco Carrara Gioia
Brushed Bianco Carrara Gioia marble

STRUTTURA/STRUCTURE



Metallo laccato "deep black"
"deep black" lacquered metal



▲ **SIR T 32**
Piano in cristallo trasparente temperato / Struttura in ottone satinato
Transparent tempered glass top / Satin brass metal structure

Sir T 32/Sir T32 C

Pierangelo Gallotti / 1971

Tavolino con piano in cristallo trasparente, extralight o "grigio Italia" temperato 10mm. Struttura in ottone cromato. A richiesta ottone lucido o satinato.

Coffee table with 10mm transparent, extralight or smoked "grigio Italia" tempered glass top. Chromed brass structure. Bright or satin brass metal parts, on request.

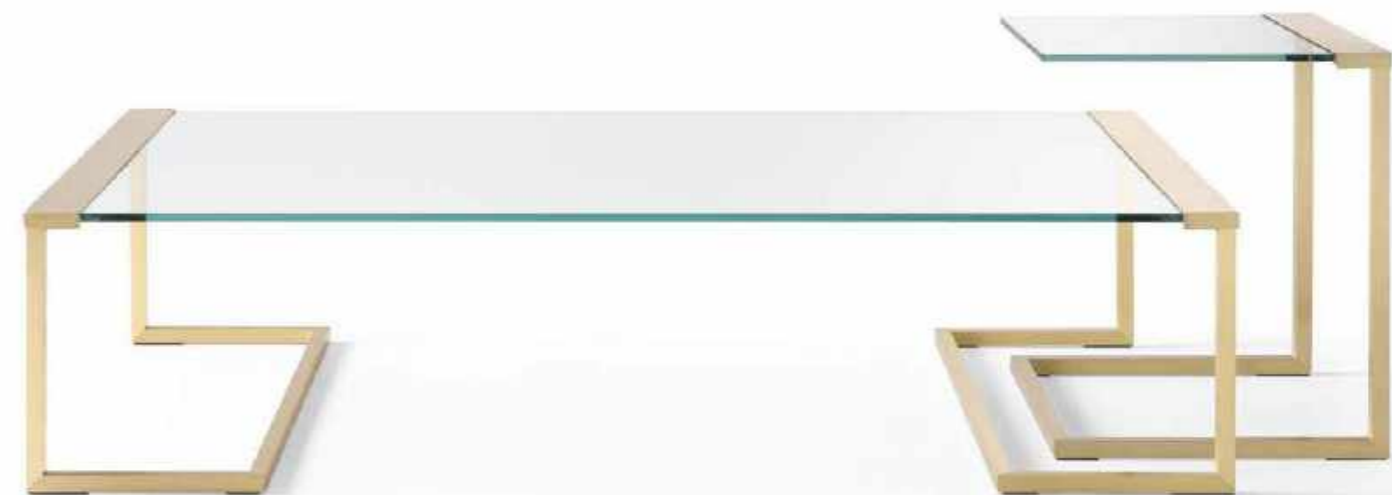

Cm

80 x 80 x 33
100 x 100 x 33
120 x 60 x 33
120 x 120 x 33
140 x 60 x 33
140 x 80 x 33

Sir T/32C

40 x 45 x 51

Inches

31½" x 31½" x 13"
39½" x 39½" x 13"
47¼" x 23¾" x 13"
47¼" x 47¼" x 13"
55½" x 23¾" x 13"
55½" x 31½" x 13"

Sir T/32C

15¾" x 17¾" x 20¼"

For technical drawing / p. 316

Pricelist 2023 / p. 152

PIANO/TOP



Cristallo trasparente
Transparent glass



Cristallo extralight
Extralight glass



Cristallo "grigio Italia"
"Grigio Italia" glass

STRUTTURA/STRUCTURE



Ottone cromato
Chrome



Ottone lucido
Bright brass



Ottone satinato
Satin brass

T 33

Pierangelo Gallotti / 1982

Tavolino con piano in cristallo temperato trasparente 10 mm. Disponibile anche in cristallo temperato extralight o "grigio Italia" 10mm. Parti metalliche in acciaio inox lucido. A richiesta acciaio inox satinato, ottone lucido, satinato o laccato bianco o nero goffrato.

Coffee table with 10mm transparent tempered glass top. Also available with 10mm extralight or smoked "grigio Italia" tempered glass. Bright stainless steel metal parts. Satin stainless steel or bright, satin brass or embossed white or black lacquered metal parts on request.

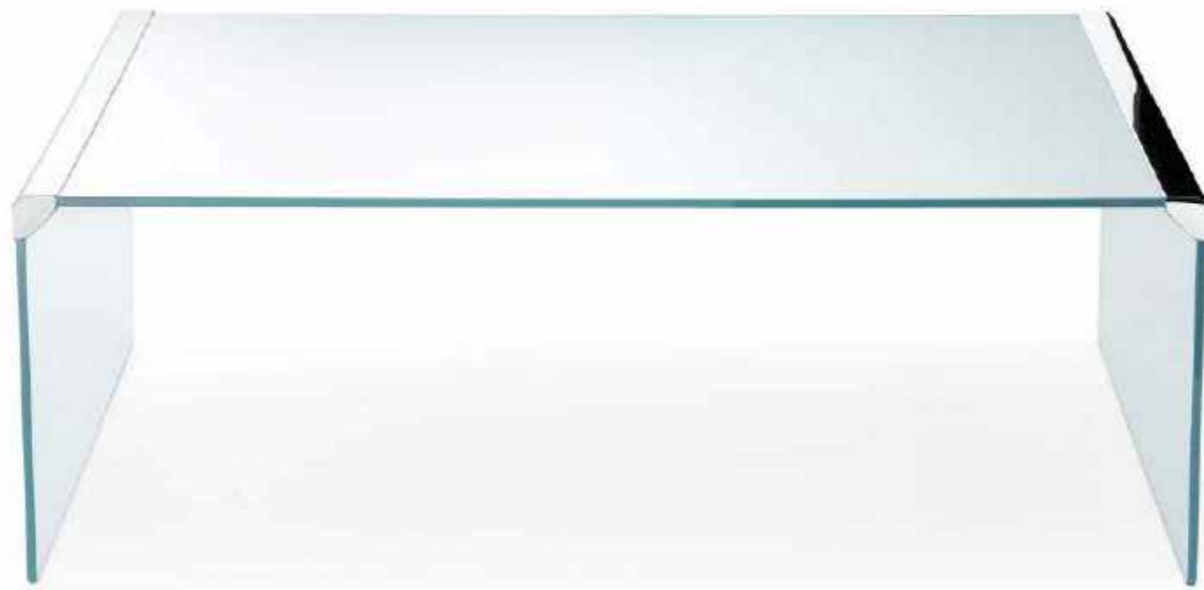

Cm

58 x 30 x 30
63 x 30 x 36
80 x 80 x 42
100 x 60 x 42
100 x 100 x 18
100 x 100 x 42
120 x 60 x 42
120 x 80 x 42
140 x 80 x 42

Inches

23" x 12" x 12"
25" x 12" x 14 1/4"
31 1/2" x 31 1/2" x 16 3/4"
39 1/2" x 23 3/4" x 16 3/4"
39 1/2" x 39 1/2" x 7 1/4"
39 1/2" x 39 1/2" x 16 3/4"
47 1/4" x 23 3/4" x 16 3/4"
47 1/4" x 31 1/2" x 16 3/4"
55 1/4" x 31 1/2" x 16 3/4"

For technical drawing / p. 317

Pricelist 2023 / p. 154

PIANO/TOP



Cristallo trasparente
Transparent glass



Cristallo "grigio Italia"
Smoked "grigio Italia" glass



Cristallo extralight
Extralight glass

PARTI METALLICHE/METAL PARTS



Acciaio inox lucido
Bright stainless steel

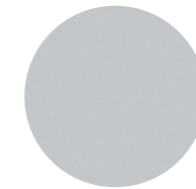

Acciaio inox satinato
Satin stainless steel

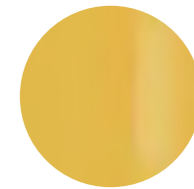

Ottone lucido
Bright brass



Ottone satinato
Satin brass



Laccato bianco goffrato
Embossed white lacquered



Laccato nero goffrato
Embossed black lacquered

▲ T 33

Piano in cristallo trasparente temperato / Parti metalliche in acciaio inox lucido
Transparent tempered glass top / Bright stainless steel metal parts

T 35 R

Pierangelo Gallotti / 1975

Serie di 3 tavolini in cristallo trasparente temperato 8mm. Disponibile anche in cristallo temperato extralight o "grigio Italia" 8mm. Parti metalliche in acciaio inox lucido. A richiesta acciaio inox satinato, ottone lucido, satinato o laccato bianco o nero goffrato.

Set of three coffee tables in 8mm transparent tempered glass. Also available in 8mm extralight or smoked "grigio Italia" tempered glass. Bright stainless steel metal parts. Satin stainless steel or bright, satin brass or embossed white or black lacquered metal parts on request.



Cm

35 x 40 x 39
80 x 40 x 42
Set 80 x 40 x 42
45 x 50 x 39
100 x 50 x 42
Set 100 x 50 x 42

Inches

14" x 15¾" x 15½"
31½" x 15¾" x 16¾"
Set 31½" x 15¾" x 16¾"
17¾" x 19¾" x 15½"
39½" x 19¾" x 16¾"
Set 39½" x 19¾" x 16¾"

[For technical drawing / p. 317](#)

[Pricelist 2023 / p. 156](#)

PIANO/TOP



Cristallo trasparente
Transparent glass



Cristallo "grigio Italia"
Smoked "grigio Italia" glass



Cristallo extralight
Extralight glass

PARTI METALLICHE/METAL PARTS



Acciaio inox lucido
Bright stainless steel

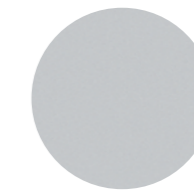

Acciaio inox satinato
Satin stainless steel

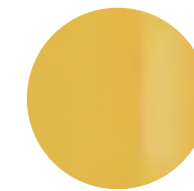

Ottone lucido
Bright brass



Ottone satinato
Satin brass

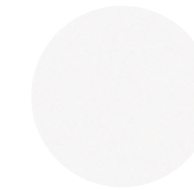

Laccato bianco goffrato
Embossed white lacquered



Laccato nero goffrato
Embossed black lacquered

▲ T 35 R

Piano in cristallo trasparente temperato / Parti metalliche in acciaio inox lucido
Transparent tempered glass top / Bright stainless steel metal parts



▲ T 35 TRIO
Piano in cristallo trasparente temperato / Parti metalliche in acciaio inox lucido
Transparent tempered glass top / Bright stainless steel metal parts

T 35 Trio

Pierangelo Gallotti / 1975

Serie di 3 tavolini in cristallo trasparente temperato 8mm. Disponibile anche in cristallo temperato extralight o "grigio Italia" 8mm. Parti metalliche in acciaio inox lucido. A richiesta acciaio inox satinato, ottone brillante, satinato o laccato bianco o nero gofrato.

Set of three coffee tables in 8mm transparent tempered glass. Also available in 8mm extralight or smoked "grigio Italia" tempered glass. Bright stainless steel metal parts. Satin stainless steel, bright, satin brass or embossed white or black lacquered metal parts on request.

Cm

38 x 40 x 36
43 x 40 x 39
48 x 40 x 42
Set 48 x 40 x 42

Inches

15" x 15¾" x 14¼"
17" x 15¾" x 15½"
19" x 15¾" x 16¾"
Set 19" x 15¾" x 16¾"

[For technical drawing / p. 317](#)

[Pricelist 2023 / p. 158](#)

PIANO/TOP



Cristallo trasparente
Transparent glass



Cristallo "grigio Italia"
Smoked "grigio Italia" glass



Cristallo extralight
Extralight glass

PARTI METALLICHE/METAL PARTS



Acciaio inox lucido
Bright stainless steel

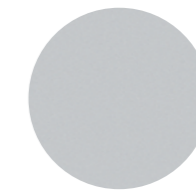

Acciaio inox satinato
Satin stainless steel

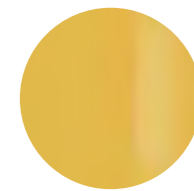

Ottone lucido
Bright brass



Ottone satinato
Satin brass



Laccato bianco gofrato
Embossed white lacquered

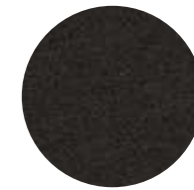

Laccato nero gofrato
Embossed black lacquered

Tetris

Massimo Castagna / 2014

Tavolino in cristallo temperato 6mm stopsol bronzo, extralight o retroverniciato nero brillante. Struttura in ottone brunito a mano. L'ottone risulta naturalmente macchiato e disomogeneo. Questa lavorazione artigianale conferisce ad ogni pezzo una particolare unicità, rendendolo esclusivo. Non realizzabile su misura.

Coffee table in 6mm bronze stopsol, extralight or bright black painted tempered glass. Structure in hand burnished brass. The hand burnished brass finish looks naturally spotted and irregular. Due to this craftmade processing, each product is unique and exclusive. Not available in custom size.

NOTE TECNICHE SUI MATERIALI

OTTONE BRUNITO A MANO | L'ottone brunito a mano è ottenuto da un processo di ossidazione naturale eseguito manualmente. Il risultato di questa lavorazione è un prodotto che può presentare macchie e variazioni di colore che non sono da considerarsi imperfezioni ma caratteristiche che conferiscono ad ogni pezzo una particolare unicità, rendendolo esclusivo.

TECHNICAL INFORMATION ON THE MATERIALS

HAND BURNISHED BRASS | The hand burnished brass is the consequence of hand-made process of natural oxidation. The result of this processing is a product that may show marks and colour variations. These differences are inevitable and should not be considered imperfections but distinctive features due to this craftmade processing, each product is unique and exclusive.



Cm

35 x 35 x 25
35 x 35 x 35
35 x 35 x 40
35 x 45 x 40
70 x 35 x 35
70 x 70 x 30

Inches

14" x 14" x 10"
14" x 14" x 14"
14" x 14" x 15 3/4"
14" x 17 3/4" x 15 3/4"
27 3/4" x 14" x 14"
27 3/4" x 27 3/4" x 12"

For technical drawing / p. 318

Pricelist 2023 / p. 159

PIANO/TOP



Cristallo stopsol bronzo
Bronze stopsol glass



Cristallo extralight
Extralight glass

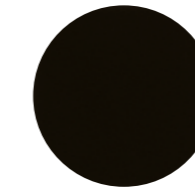

Cristallo retroverniciato nero brillante
Bright black painted tempered glass.

STRUTTURA/STRUCTURE



Ottone brunito a mano
Hand burnished brass

▲ **TETRIS**
Piano in cristallo temperato stopsol bronzo / Piano in cristallo retroverniciato nero brillante
Bronze Stopsol tempered glass top / Bright black painted tempered glass top



▲ **TWELVE**
 Piano in marmo Calacatta Vagli Oro / Ciotola in ottone lucido / Struttura in ottone brunito a mano
 Calacatta Vagli Oro marble top / Bright black painted tempered glass top / Hand burnished brass structure

Twelve

Massimo Castagna / 2016

Tavolino con piano marmo lucido naturale Calacatta Vagli Oro oppure con ciotola in ottone lucido. Struttura in ottone brunito a mano.

Coffee table with natural polished Calacatta Vagli Oro marble top or with bright brass plate. Hand burnished brass structure.

NOTE TECNICHE SUI MATERIALI

MARMO | Il marmo è un materiale naturale di origine sedimentaria che può presentare particolarità come venature, lievi irregolarità superficiali, colorazioni differenti e cristallizzazioni. Queste peculiarità sono da attribuirsi alla naturalezza del materiale e non sono da considerarsi difetti ma caratteristiche tipiche del marmo. Ogni prodotto risulterà unico, esclusivo e non replicabile.

I nostri marmi vengono trattati con un prodotto idrorepellente che permette una maggiore protezione della superficie stessa, aumentando l'impermeabilità. Questo trattamento non esclude la vulnerabilità del marmo alle sostanze acide.

OTTONE BRUNITO A MANO | L'ottone brunito a mano è ottenuto da un processo di ossidazione naturale eseguito manualmente. Il risultato di questa lavorazione è un prodotto che può presentare macchie e variazioni di colore che non sono da considerarsi imperfezioni ma caratteristiche che conferiscono ad ogni pezzo una particolare unicità, rendendolo esclusivo.

TECHNICAL INFORMATION ON THE MATERIALS

MARBLE | The marble is a natural material of sedimentary origin that can present particularities such as veins, slight surface irregularities, different colors and crystallizations. These peculiarities are to be attributed to the naturalness of the material and are not to be considered defects but typical characteristics of marble. Each product will be unique, exclusive and non-replicable.

Our marbles are treated with water-repellent products which affords greater protection to the surface of the marble, improving its impermeability. This treatment doesn't exclude the vulnerability of the marble to acid substances.

HAND BURNISHED BRASS | The hand burnished brass is the consequence of hand-made process of natural oxidation. The result of this processing is a product that may show marks and colour variations. These differences are inevitable and should not be considered imperfections but evidence of the hand-crafted process. They enhance the beauty and distinctiveness of a unique piece.



Cm	Inches
S Ø 19 x 48	Ø 7½" x 19"
M Ø 26 x 36	Ø 10¼" x 14¼"
L Ø 49 x 42	Ø 19½" x 16¾"
XL 80 x 80 x 25	31½" x 31½" x 10"
XXL Ø 120 x 35	Ø 47¼" x 14"

Ciotola ottone lucido	Bright brass plate
S Ø 19 x 50	Ø 7½" x 19¾"
M Ø 26 x 39	Ø 10¼" x 15½"
L Ø 49 x 47	Ø 19½" x 18¾"

[For technical drawing / p. 318](#)

[Pricelist 2023 / p. 160](#)
[Homescapes, intimate portraits / pp. 52, 55, 88, 92](#)
[Homescapes, gentle attitude / pp. 104](#)

PIANO/TOP



Marmo lucido naturale
 Calacatta Vagli Oro
 Natural polished
 Calacatta Vagli Oro marble

CIOTOLA/PLATE



Ottone lucido
 Bright brass

STRUTTURA/STRUCTURE



Ottone brunito a mano
 Hand burnished brass

Zen Black Low

Massimo Castagna / 2020

Tavolino con piano in frassino spazzolato tinto nero poro aperto, in cristallo temperato decorato a mano nella finitura Craquelé, in marmo lucido naturale Verde Alpi e Bianco Carrara Gioia, in marmo Nero Marquinia levigato opaco o in marmo Fior di Pesco spazzolato. Base in alluminio spazzolato a mano e anodizzato nero con dettagli in metallo laccato nero.

NOTE TECNICHE SUI MATERIALI

CRISTALLO | Le finiture esclusive risultato della lavorazione manuale realizzata sul cristallo possono presentare striature e differenze cromatiche. Queste caratteristiche non devono essere considerate difetti ma elementi distintivi del processo artigianale che esaltano la bellezza e la peculiarità del pezzo unico.

MARMO | Il marmo è un materiale naturale di origine sedimentaria che può presentare particolarità come venature, lievi irregolarità superficiali, colorazioni differenti e cristallizzazioni. Queste peculiarità sono da attribuirsi alla naturalezza del materiale e non sono da considerarsi difetti ma caratteristiche tipiche del marmo. Ogni prodotto risulterà unico, esclusivo e non replicabile.

I nostri marmi vengono trattati con un prodotto idrorepellente che permette una maggiore protezione della superficie stessa, aumentando l'impermeabilità. Questo trattamento non esclude la vulnerabilità del marmo alle sostanze acide.

Coffee table with black brushed open pore stained ash top. Also available with tempered hand decorated Craquelé glass top or in natural polished Verde Alpi or Bianco Carrara Gioia, in honed mat Nero Marquinia or brushed Fior di Pesco marble. Black hand brushed anodised aluminium base with black lacquered metal details.

TECHNICAL INFORMATION ON THE MATERIALS

GLASS | Exclusive finishes, resulting from the craftsmanship on the glass, may show streaks and chromatic differences. These characteristics should not be considered imperfections but distinctive evidence of the hand-made process that enhance the beauty and peculiarity of the unique piece.

MARBLE | The marble is a natural material of sedimentary origin that can present particularities such as veins, slight surface irregularities, different colors and crystallizations. These peculiarities are to be attributed to the naturalness of the material and are not to be considered defects but typical characteristics of marble. Each product will be unique, exclusive and non-replicable.

Our marbles are treated with water-repellent products which affords greater protection to the surface of the marble, improving its impermeability. This treatment doesn't exclude the vulnerability of the marble to acid substances.



Cm
Ø 100 x 47
Ø 120 x 47

Inches
Ø 39½" x 18¾"
Ø 47½" x 18¾"

[For technical drawing / p. 318](#)

[Pricelist 2023 / p. 161](#)

PIANO/TOP

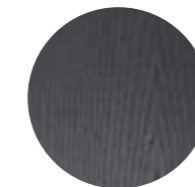

Frassino spazzolato tinto nero poro aperto
Black open pore brushed stained ash



Cristallo Craquelé
Craquelé glass



Marmo lucido naturale Bianco Carrara Gioia
Natural polished Bianco Carrara Gioia marble



Marmo spazzolato Fior di Pesco
Brushed Fior di Pesco marble



Marmo levigato opaco Nero Marquinia
Honed mat Nero Marquinia marbl



Marmo lucido naturale Verde Alpi
Natural polished Verde Alpi marble

BASE/BASE

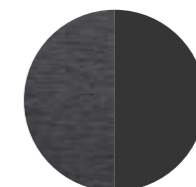

Alluminio spazzolato e anodizzato nero/ Metallo laccato nero
Hand brushed anodised aluminium / Black metal details

▲ ZEN BLACK LOW

Piano in marmo lucido naturale Verde Alpi / Base in alluminio spazzolato anodizzato nero e metallo laccato nero
Natural polished Verde Alpi marble top / Black hand brushed anodised aluminium base with black metal details



▲ ZEN LOW
Piano in frassino spazzolato tinto nero poro aperto / Piano in cristallo decorato a mano Craquelé
Black open pore brushed stained ash top / Hand-decorated Craquelé glass top

Zen Low

Massimo Castagna / 2018

Tavolino con piano in frassino spazzolato tinto nero poro aperto. Disponibile anche con piano in cristallo temperato decorato a mano nella finitura Craquelé. Base in alluminio spazzolato a mano e anodizzato nero con dettagli ottonati lucidi.

Coffee table with black open pore brushed stained ash top. Also available with tempered hand decorated Craquelé glass top. Black hand brushed anodized aluminium base with bright brass plated details.

NOTE TECNICHE SUI MATERIALI

CRISTALLO | Le finiture esclusive risultato della lavorazione manuale realizzata sul cristallo possono presentare striature e differenze cromatiche. Queste caratteristiche non devono essere considerate difetti ma elementi distintivi del processo artigianale che esaltano la bellezza e la peculiarità del pezzo unico.

TECHNICAL INFORMATION ON THE MATERIALS

GLASS | Exclusive finishes, resulting from the craftsmanship on the glass, may show streaks and chromatic differences. These characteristics should not be considered imperfections but distinctive evidence of the hand-made process that enhance the beauty and peculiarity of the unique piece.



	Cm	Inches
A	Ø 100 x 47	Ø 39½" x 18¾"
B-C-D	90 x 90 x 47	35½" x 35½" x 18¾"
E	105 x 50 x 47	41½" x 19¾" x 18¾"

[For technical drawing / p. 319](#)

[Pricelist 2023 / p. 162](#)
[Homescapes, sense of materials / p. 92](#)

PIANO/TOP

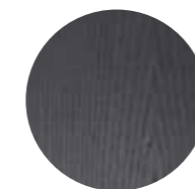

Frassino spazzolato
tinto nero poro aperto
Black open pore brushed
stained ash



Cristallo Craquelé
Craquelé glass

BASE/BASE

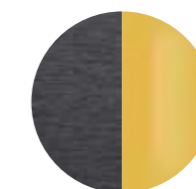

Alluminio spazzolato nero /
Metallo ottonato lucido
Black brushed aluminium /
Bright brassed metal

06

Tavolini / Coffee Tables
TECHNICAL MODULE

1968 | Studio G&R, 2019

Product information / p. 226

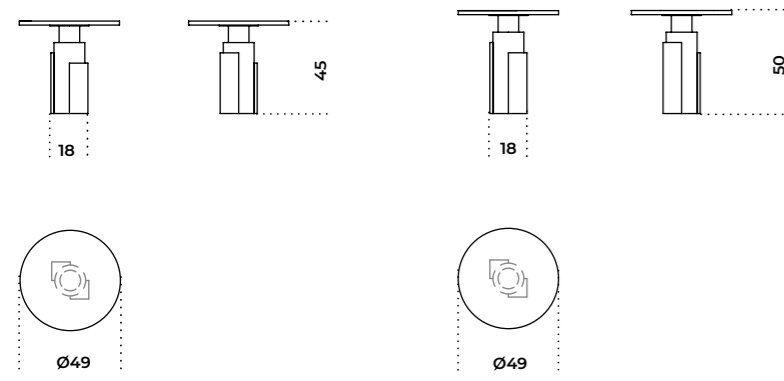

Chantal | Studio G&R, 2013

Product information / p. 228

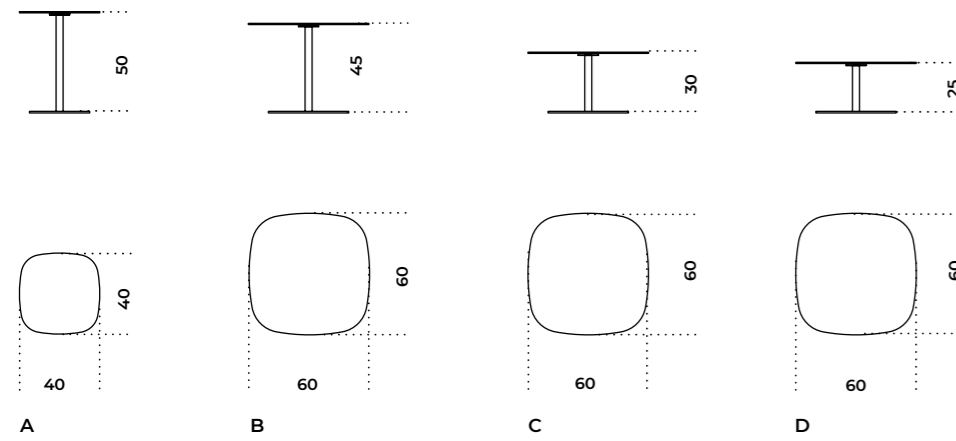

Clema | Massimo Castagna, 2021

Product information / p. 230

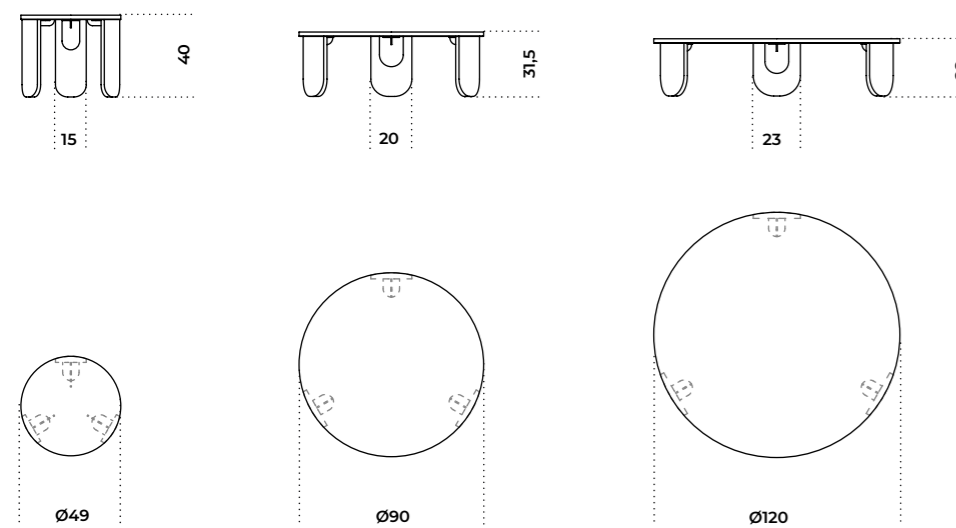

Connection | Massimo Castagna, 2013

Product information / p. 234

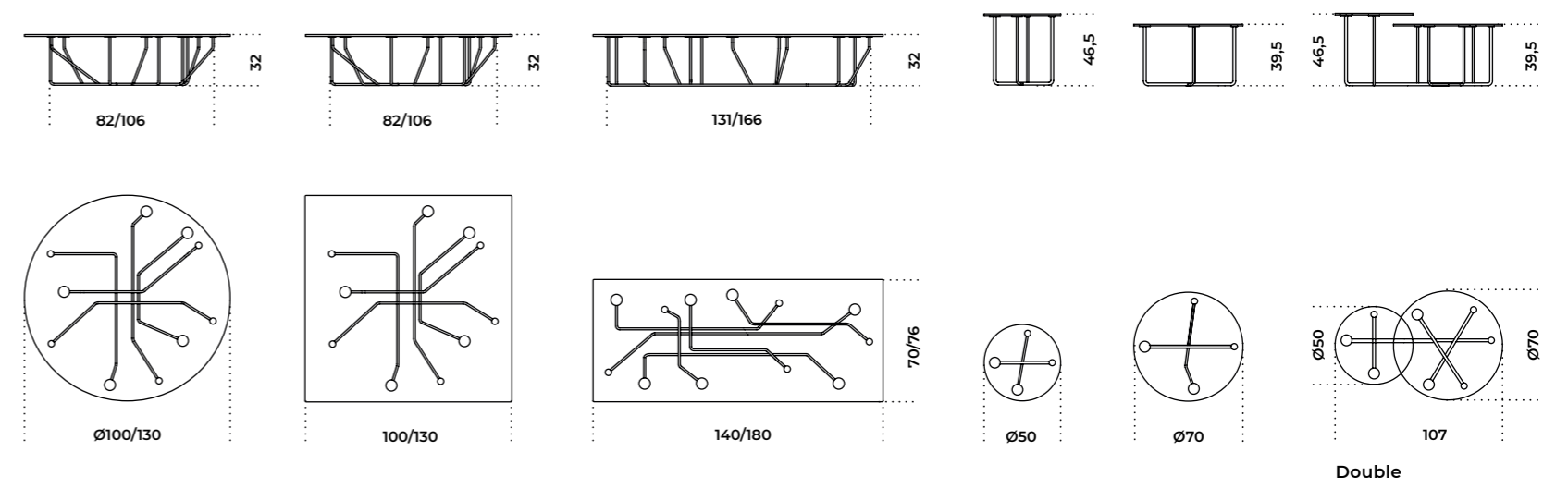

Cookies | Pietro Russo, 2017

Product information / p. 236

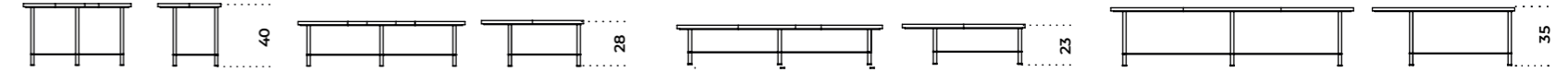

Marmo Calacatta Vagli Oro
Calacatta Vagli Oro marble

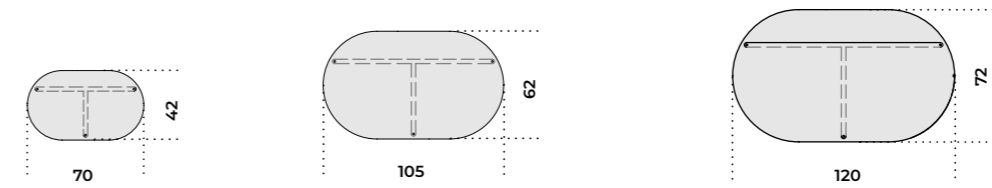

Marmo Bianco Statuario/Nero Marquina
Bianco Statuario/Nero Marquina marble

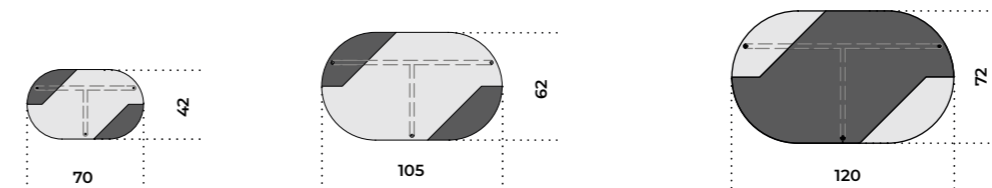

Legno Intarsiato "Tweed"/Acero Frisè
Inlaid wooden "Tweed"/Maple Frisè

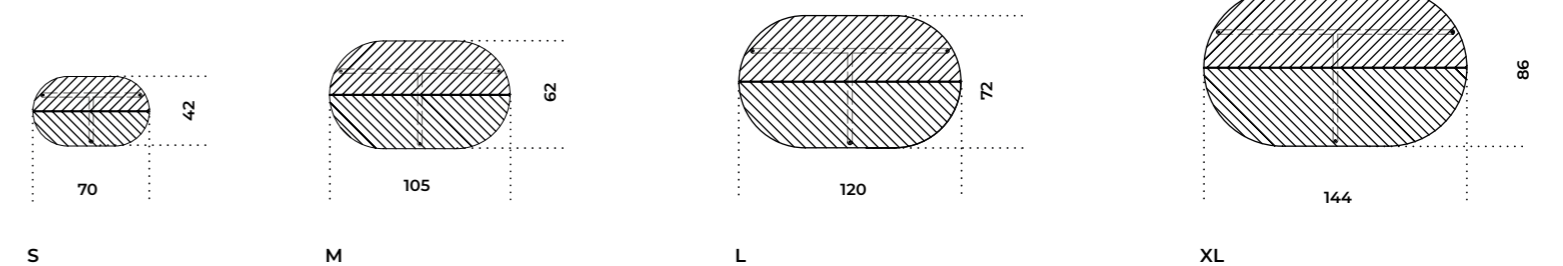

Cookies Circle | Pietro Russo, 2019

Product information / p. 238

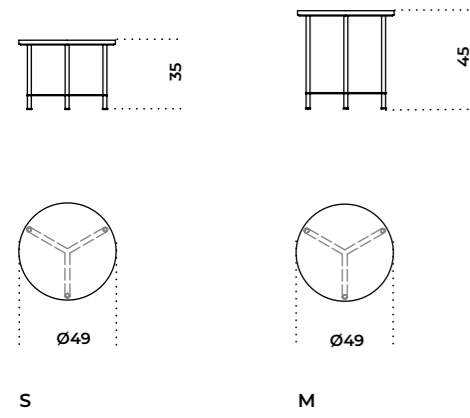

Fante | Studio G&R, 2015

Product information / p. 244

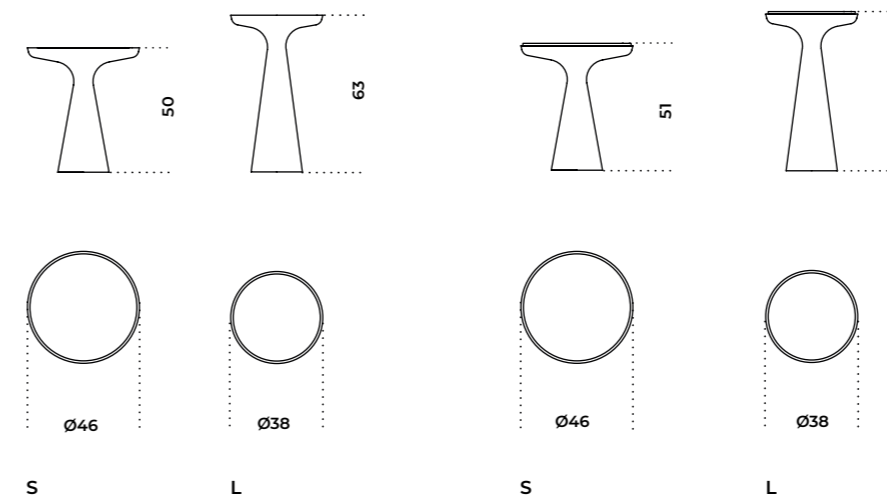

Dama | Studio G&R, 2015

Product information / p. 240

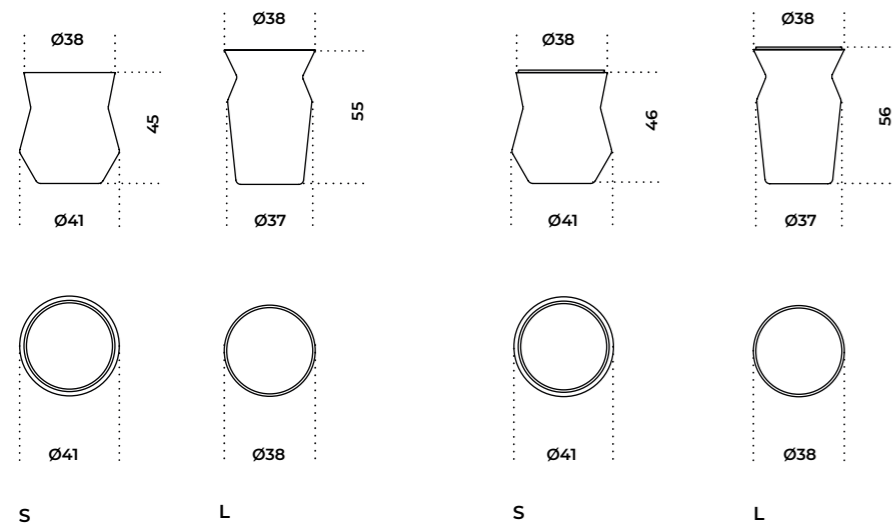

Faraday | Mårten Claesson, Ola Rune, Eero Koivisto, 2007

Product information / p. 246

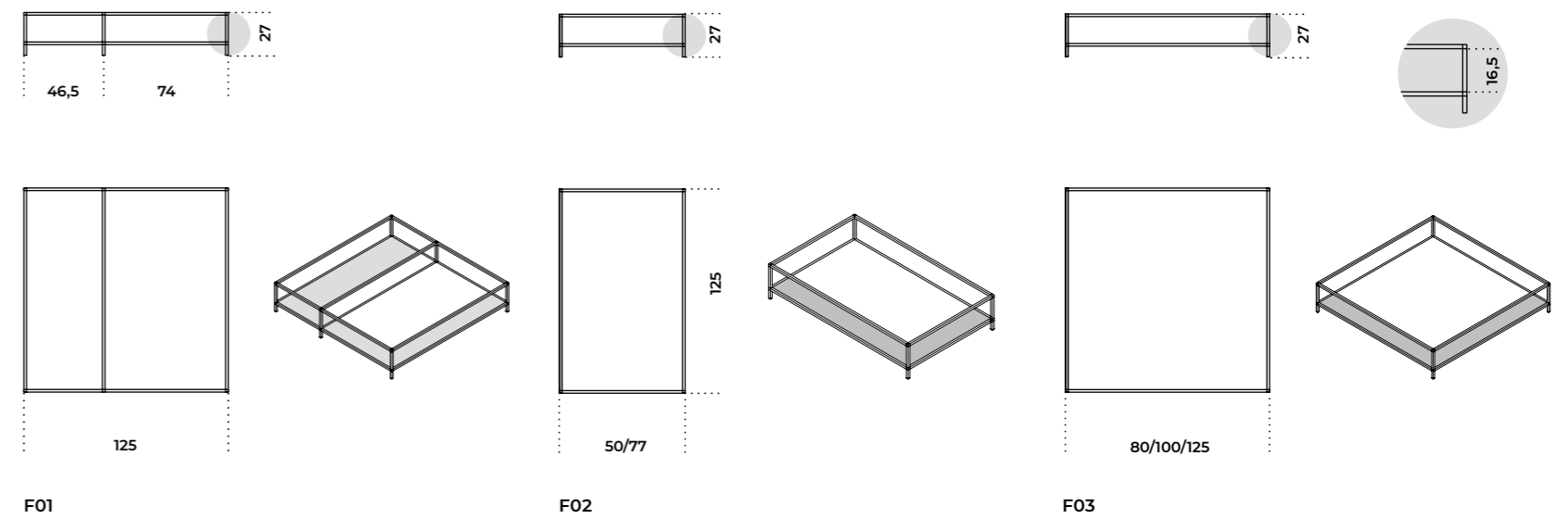

Drummers | Studiopepe, 2023

Product information / p. 242

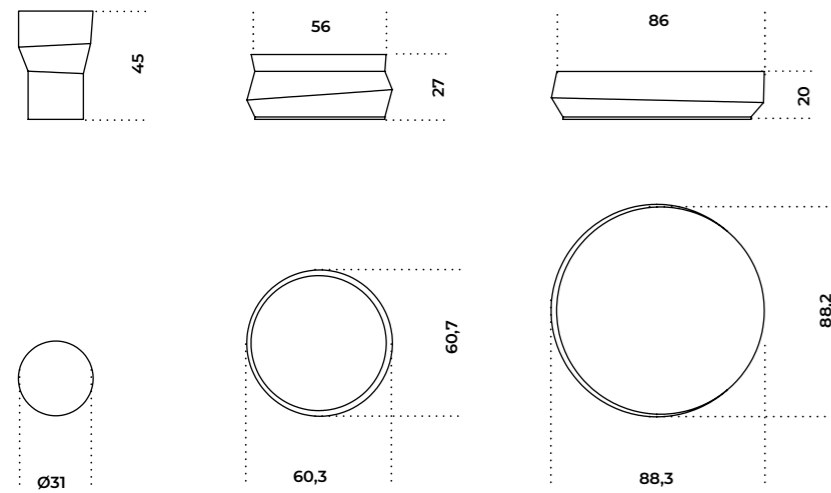

George 1 | Pierangelo Gallotti, 1975

Product information / p. 248

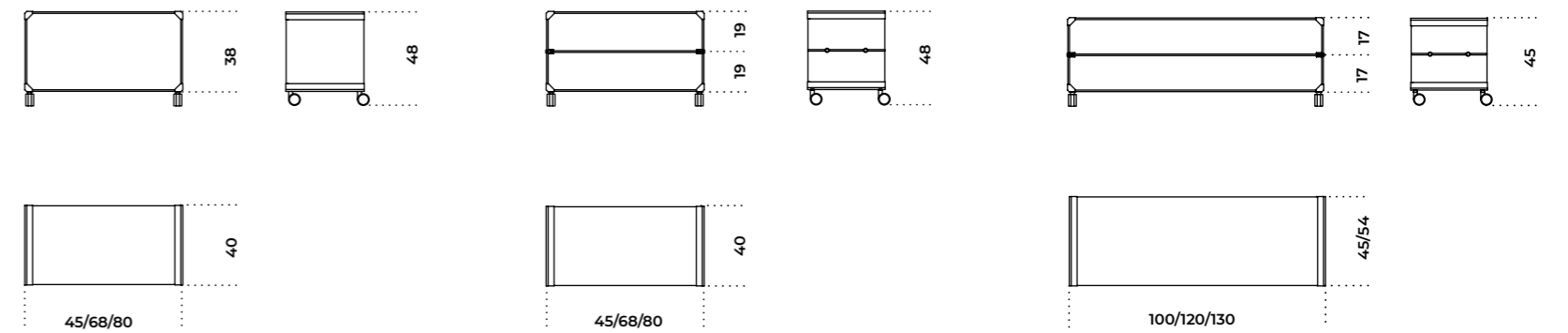

George 2 | Pierangelo Gallotti, 1975

Product information / p. 250

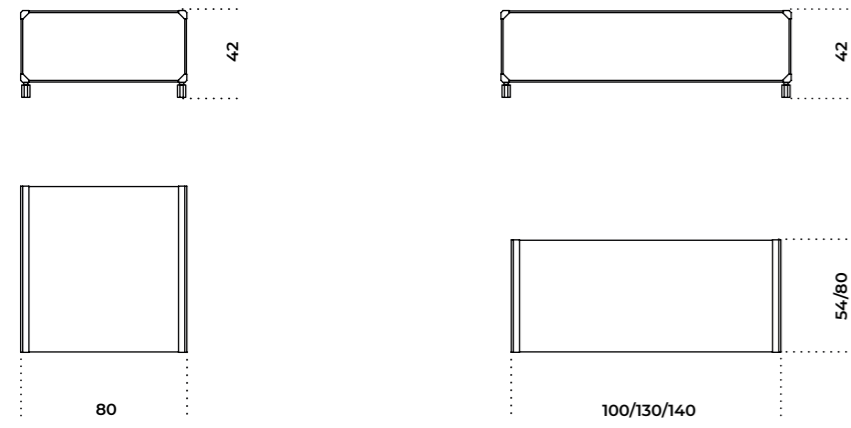

Haumea | Massimo Castagna, 2015

Product information / p. 256

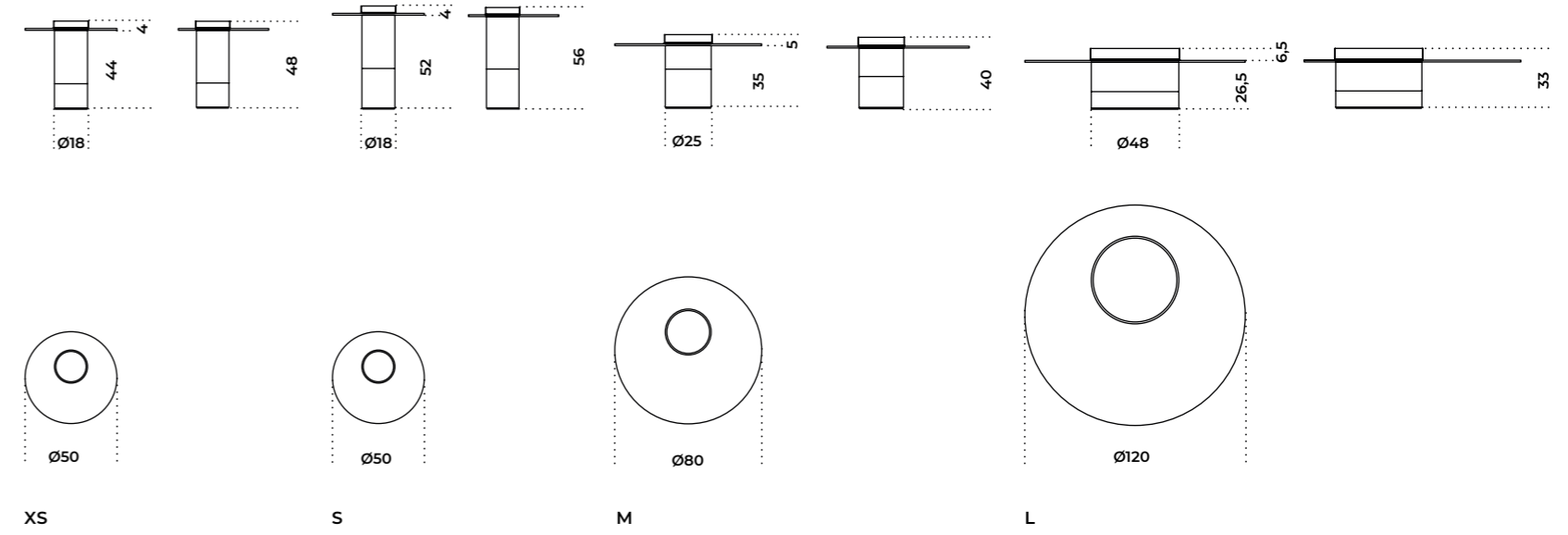

Golden Moon | Massimo Castagna, 2015

Product information / p. 252

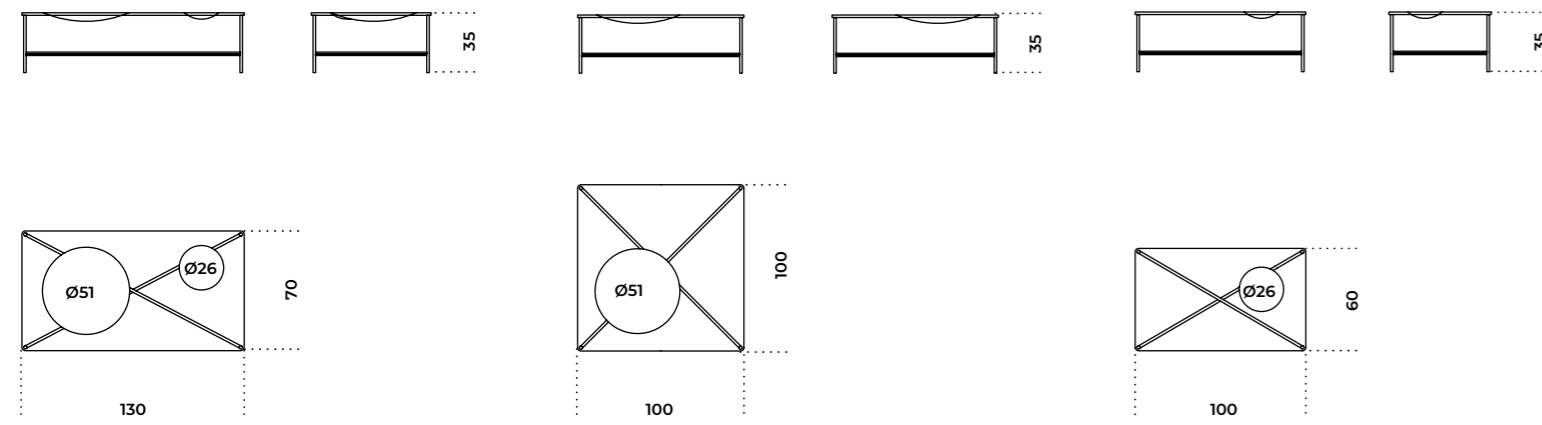

Monete | Massimo Castagna, 2021

Product information / p. 260

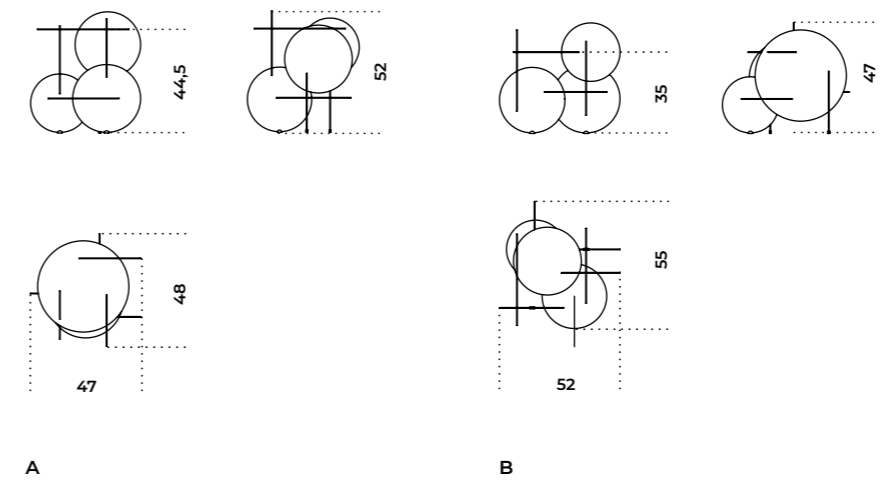

Gong | Studio G&R, 2017

Product information / p. 254

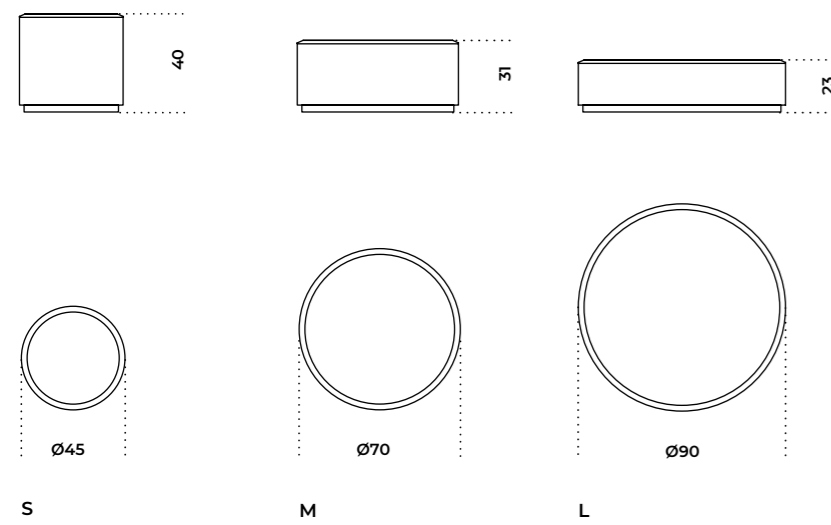

Nori | Studio G&R, 2018

Product information / p. 264

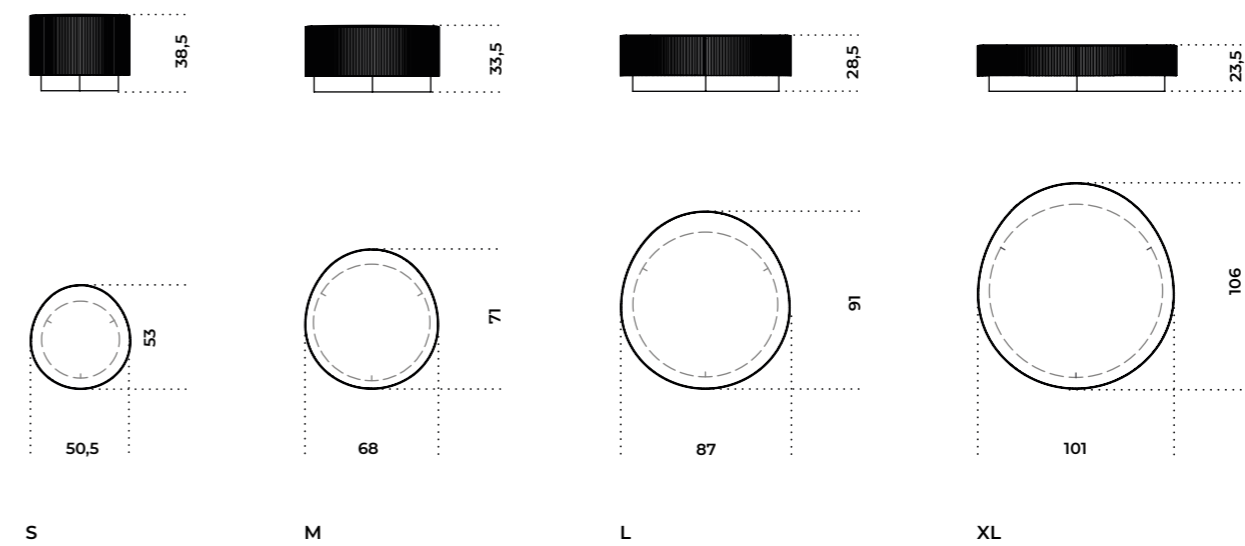

Nox | Ricardo Bello Dias, 2009

Product information / p. 266

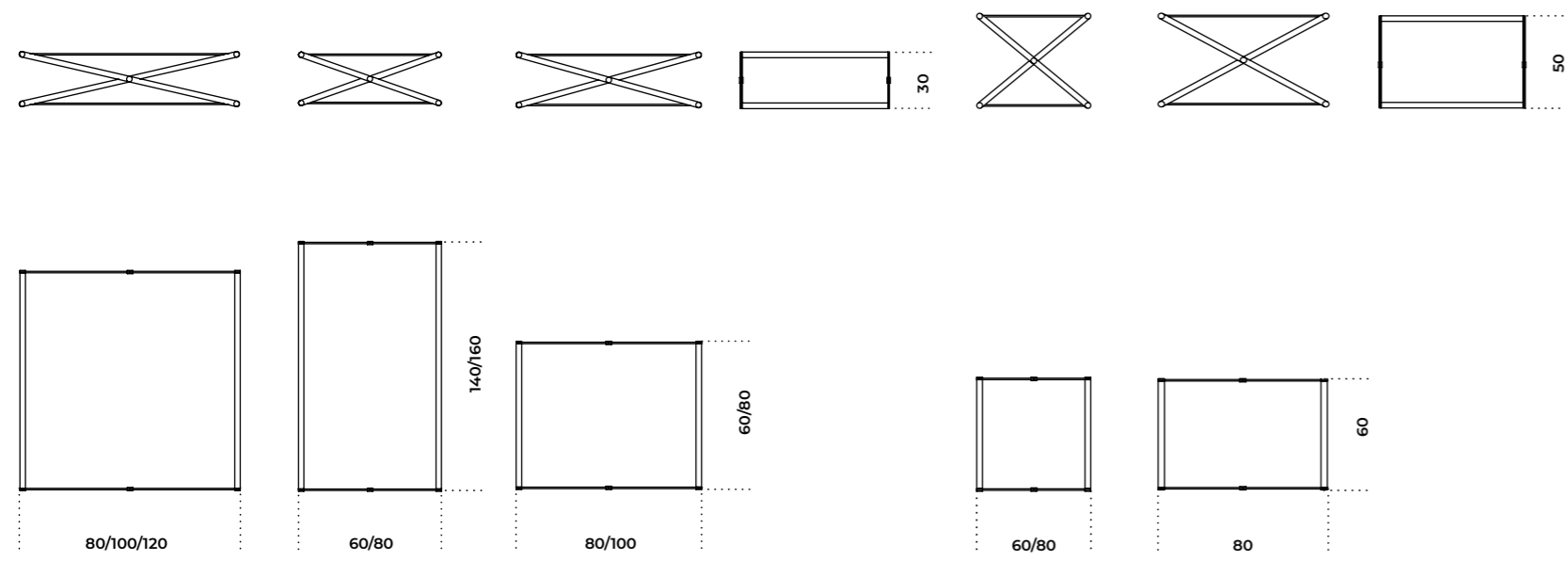

Prism Low | david/nicolas, 2020

Product information / p. 270

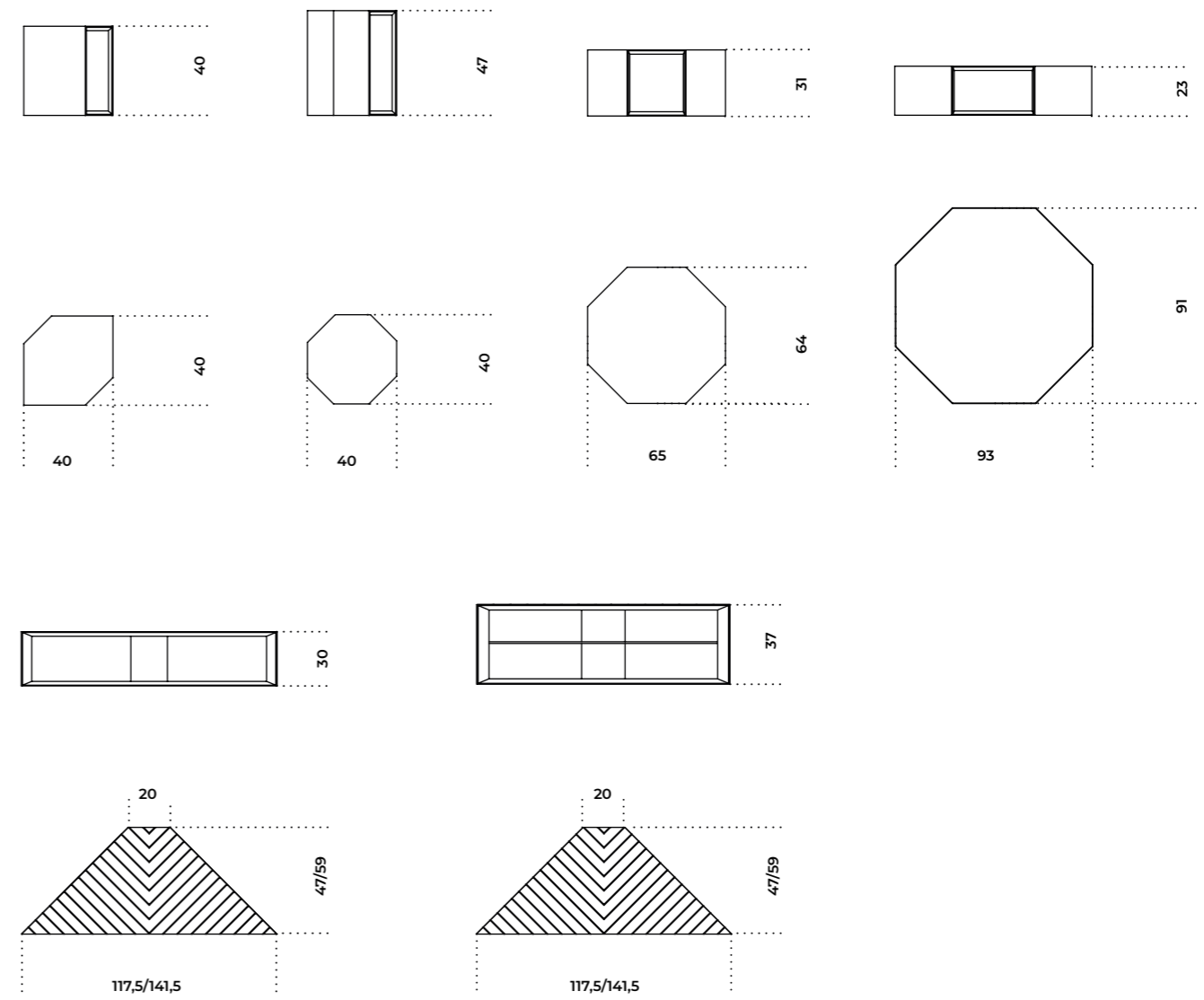

Oto Mini | Oscar e Gabriele Buratti, 2015

Product information / p. 268

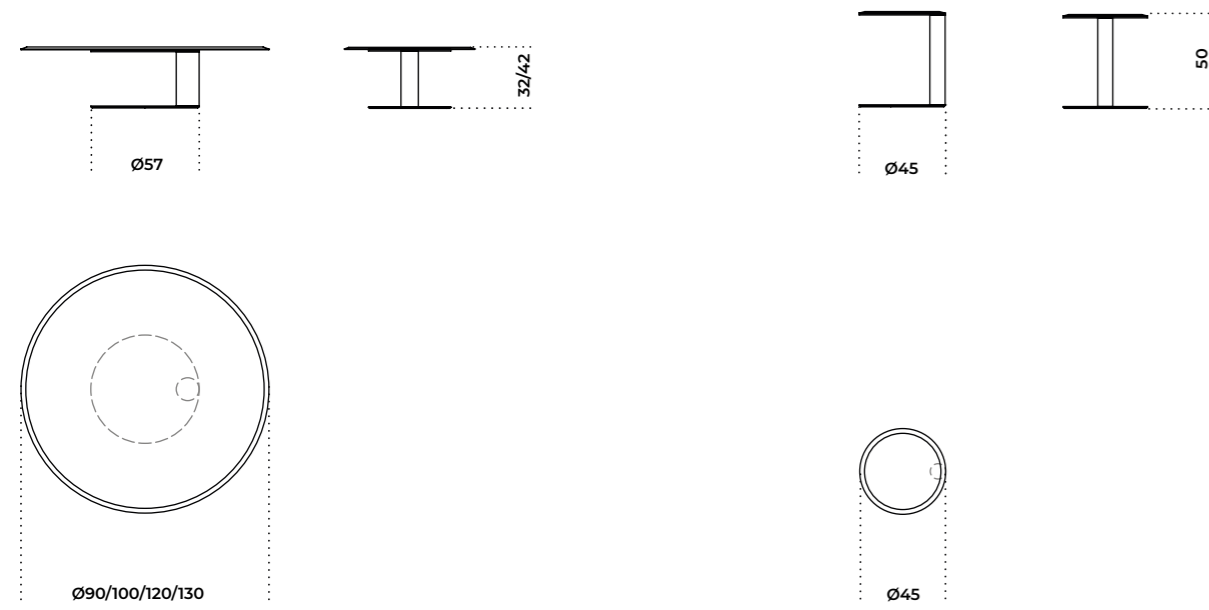

Raj1 | Ricardo Bello Dias, 2006

Product information / p. 272

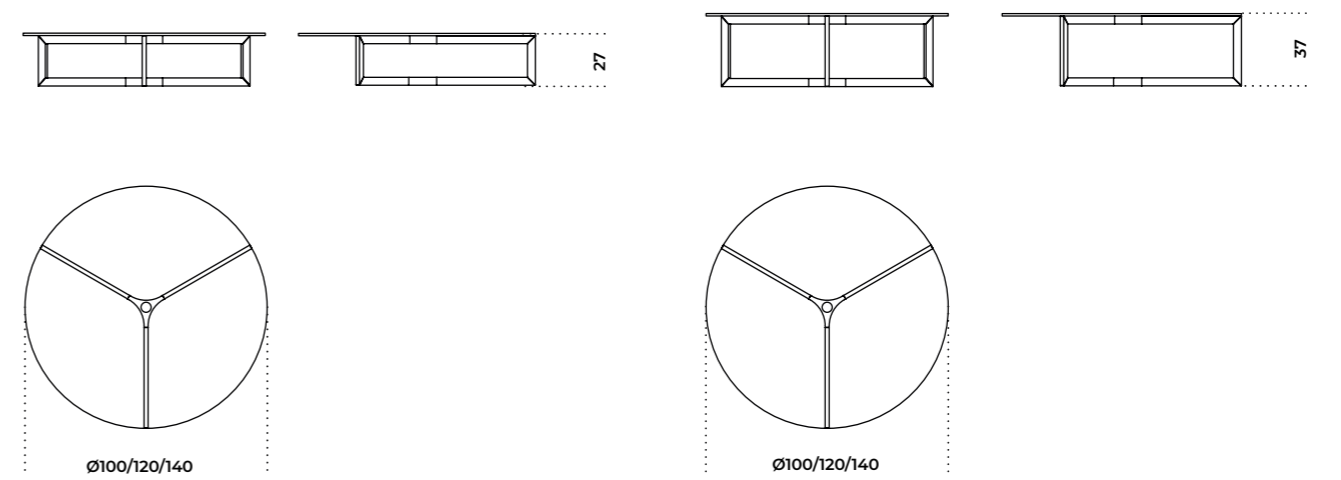

Raj 2 | Ricardo Bello Dias, 2006

Product information / p. 274

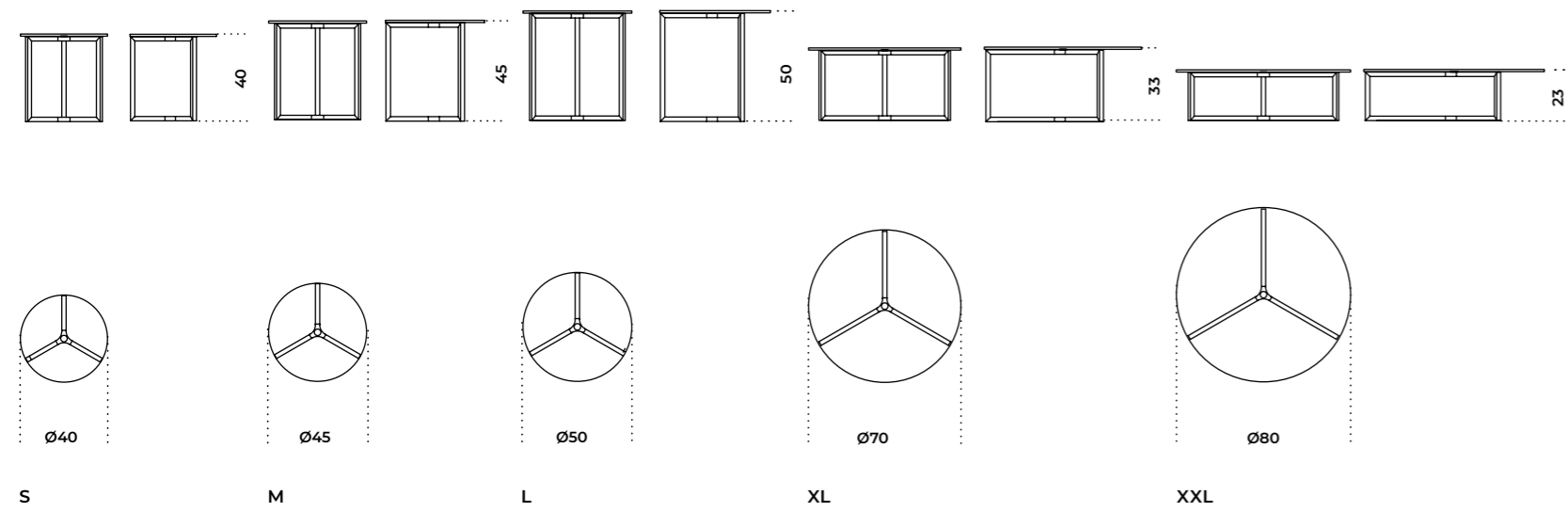

Re-verre | Federica Biasi, 2023

Product information / p. 280

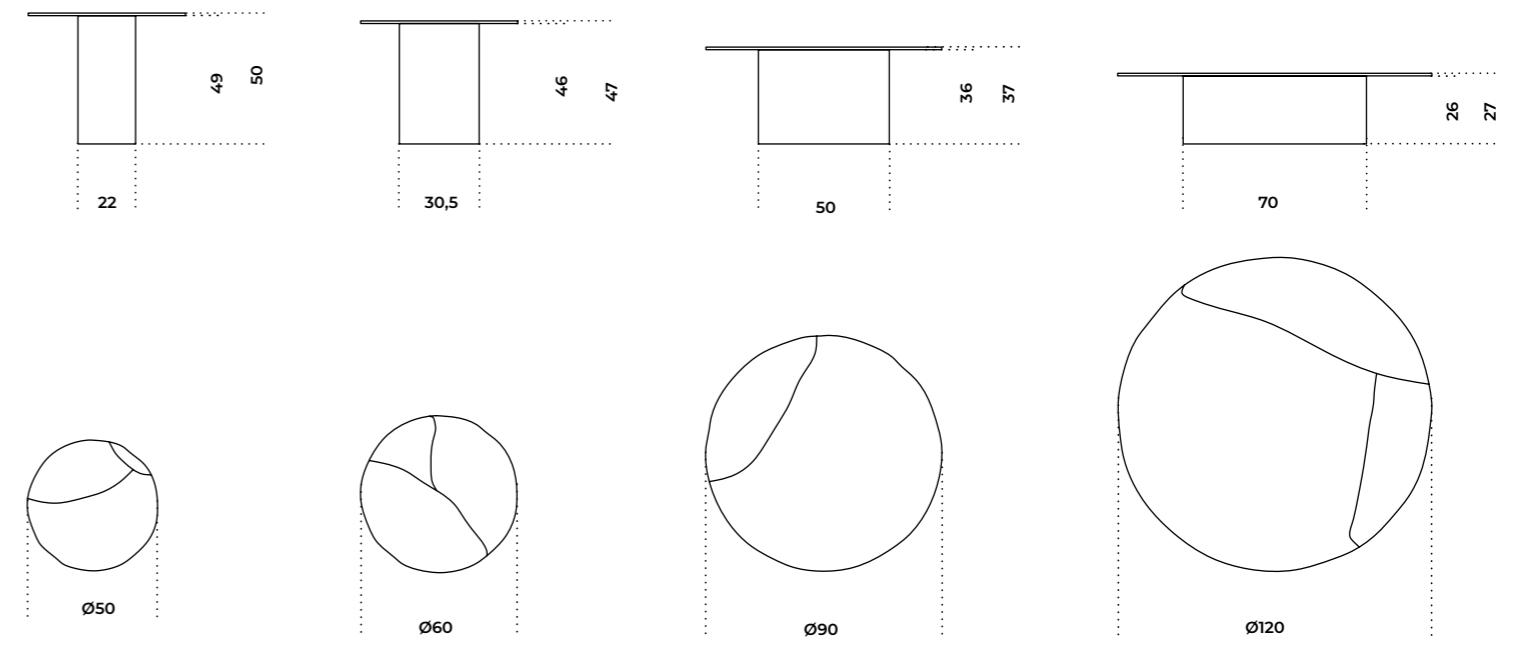

Raj 3 | Ricardo Bello Dias, 2011

Product information / p. 276

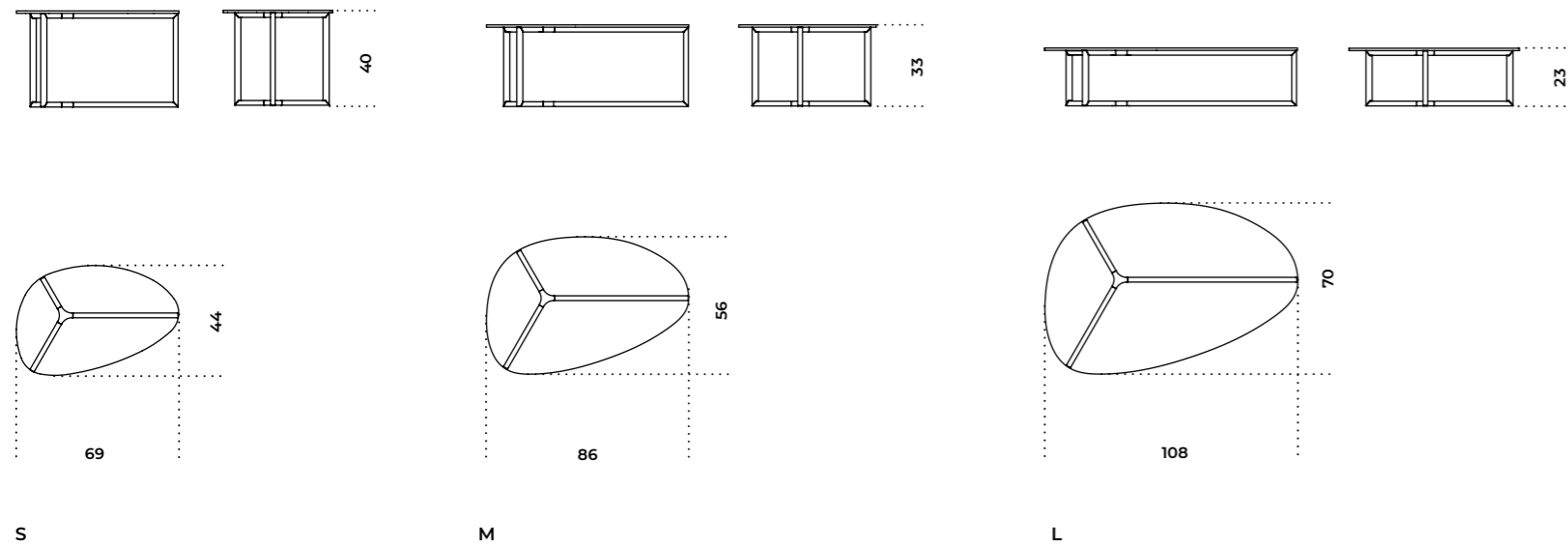

Selce | Studiopepe, 2023

Product information / p. 282

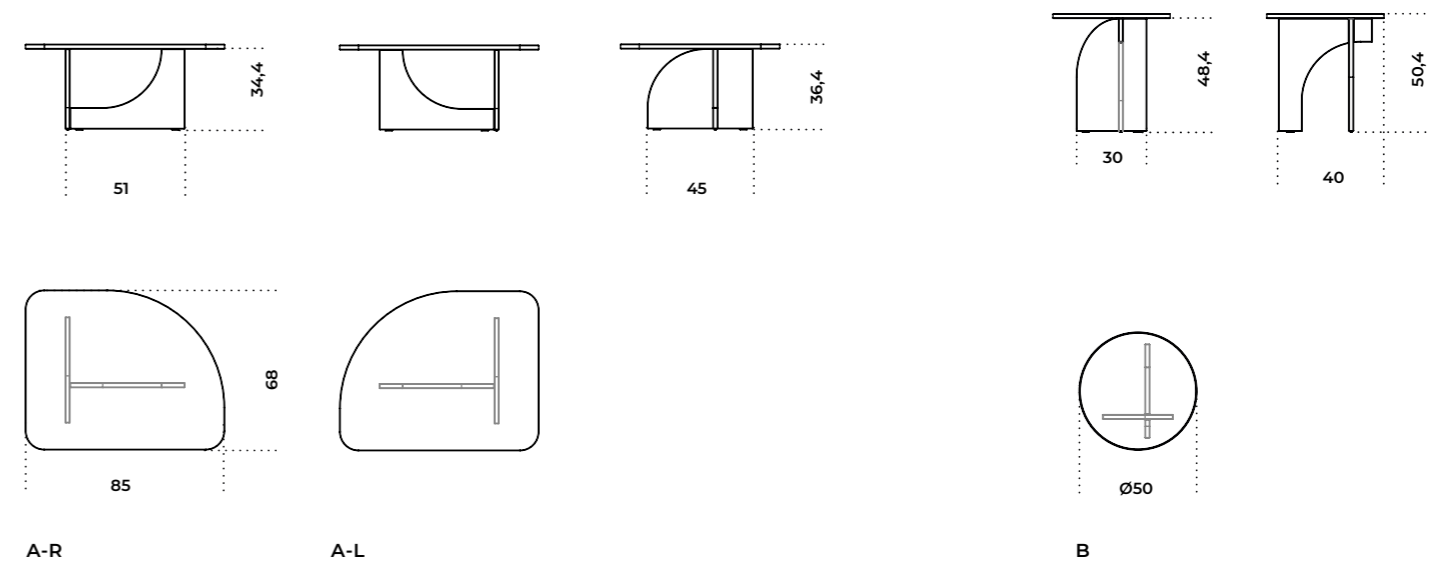

Raj 6 | Ricardo Bello Dias, 2013

Product information / p. 278

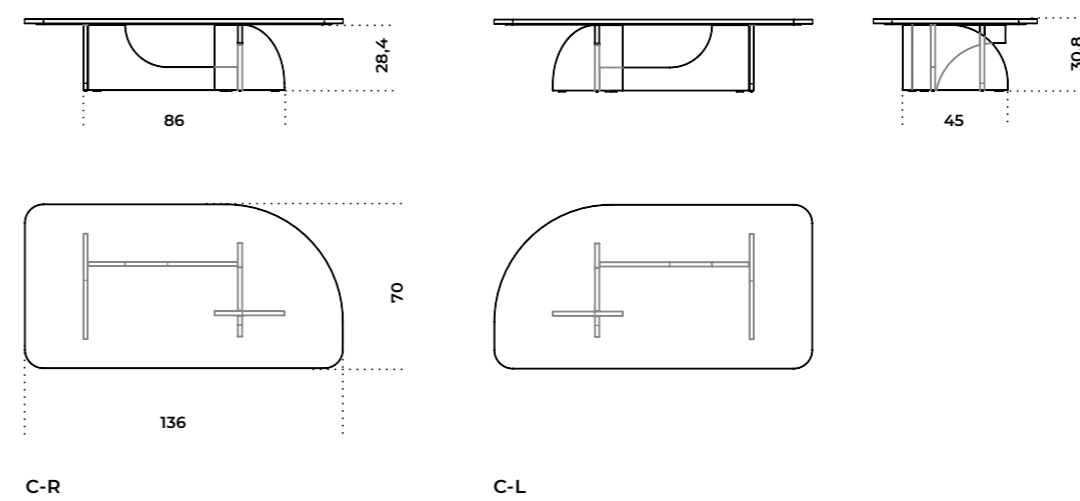
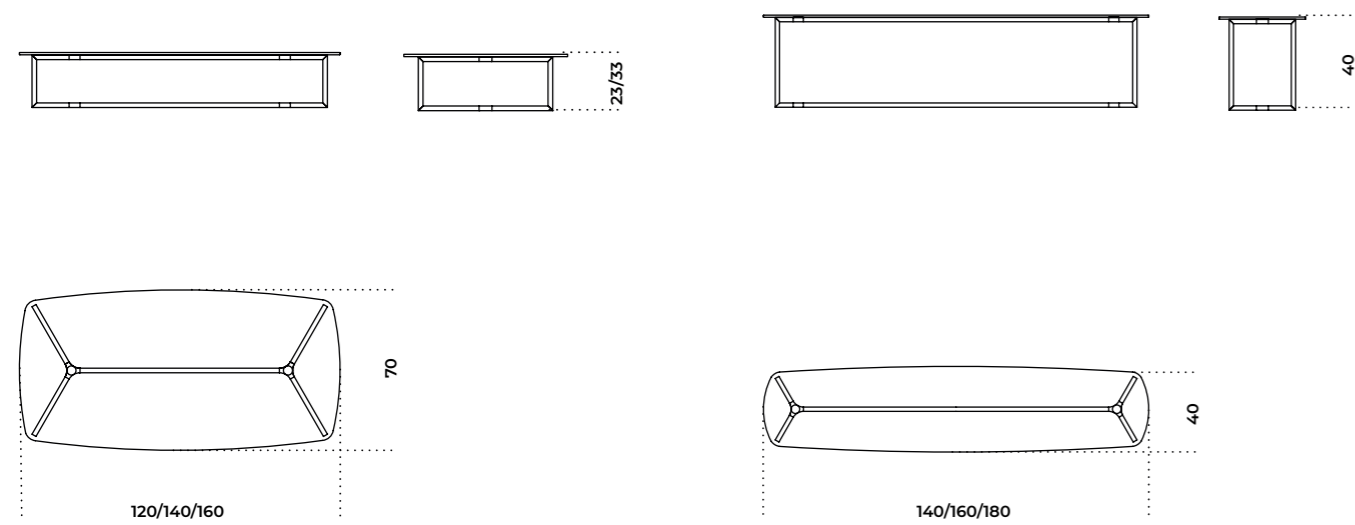

Sensei | Tollgard + Castellani, 2022

Product information / p. 284

Piano in legno con scasso
Burglary wooden top

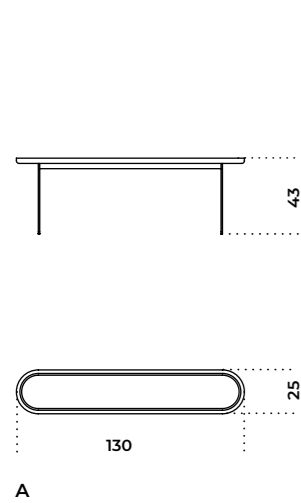

Piano in cristallo
Glass top

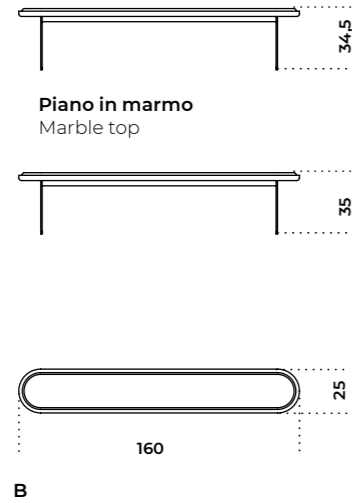

Piano in marmo
Marble top

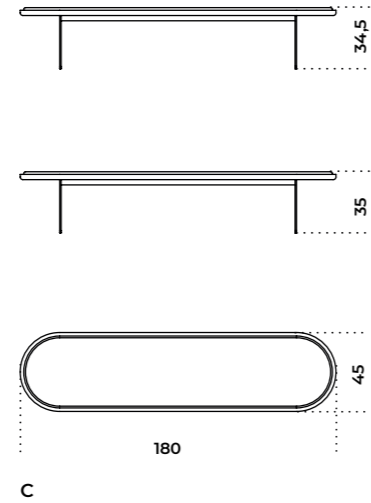
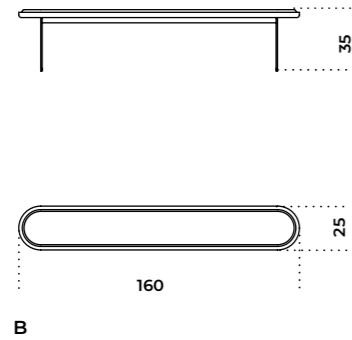

Composizioni
Compositions

Composizione 1 / Composition 1

Composta da
Composed by

n.1 D 140 x 85 x 24,5h "Rosso Marte"
n.1 C 180 x 45 x 35h Calacatta Vagli Oro
n.1 A 130 x 25 x 43h legno/wood

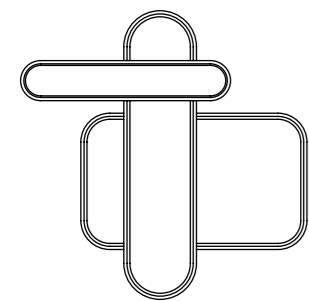

Composizione 2 / Composition 2

Composta da
Composed by

n.1 B 160 x 25 x 35h "Rosso Marte"
n.1 C 180 x 45 x 35h Calacatta Vagli Oro
n.1 A 130 x 25 x 43h legno/wood

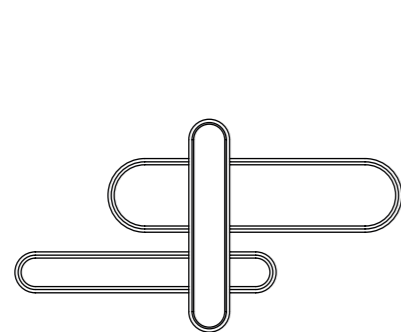

Composizione 3 / Composition 3

Composta da
Composed by

n.1 D 140 x 85 x 25h "Rosso Marte"
n.1 C 180 x 45x 35h Calacatta Vagli Oro
n.1 B 160 x 25x34,5h "Rosso Marte"

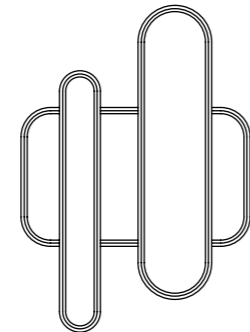

Composizione 4 / Composition 4

Composta da
Composed by

n.1 A 130 x 25 x 43h legno/wood
n.1 D 140 x 85 x 25h "Rosso Marte"
n.1 C 180 x 45x 35h Calacatta Vagli Oro
n.1 B 160 x 25x34,5h "Rosso Marte"

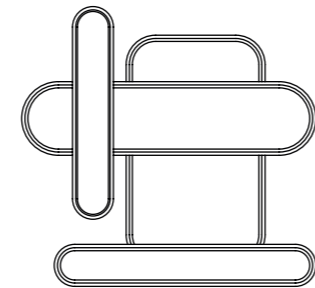

Sir T32 / Sir T32 C | Pierangelo Gallotti, 1971

Product information / p. 286

Sir T32

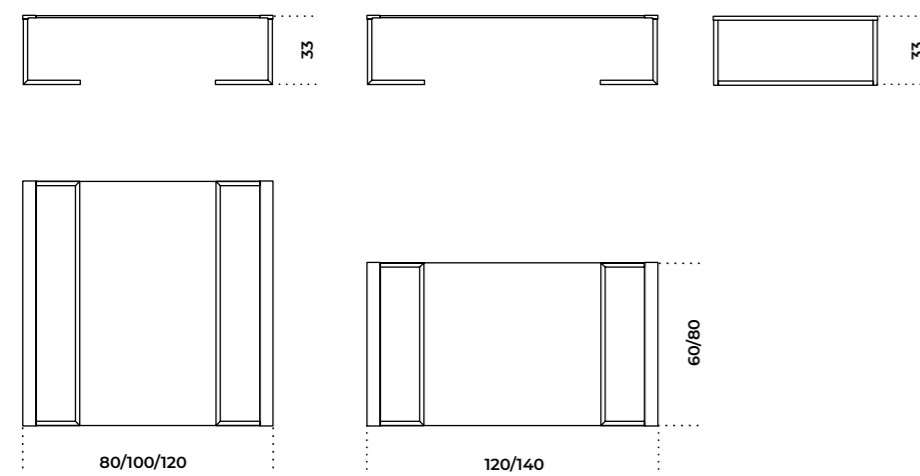

Sir T32C

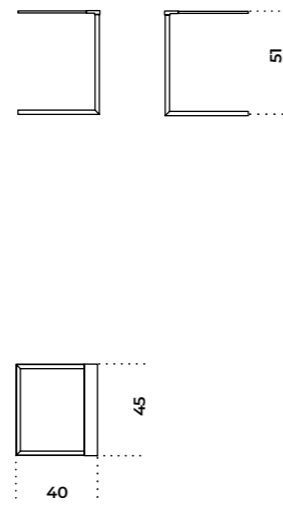

T33 | Pierangelo Gallotti, 1982

Product information / p. 288

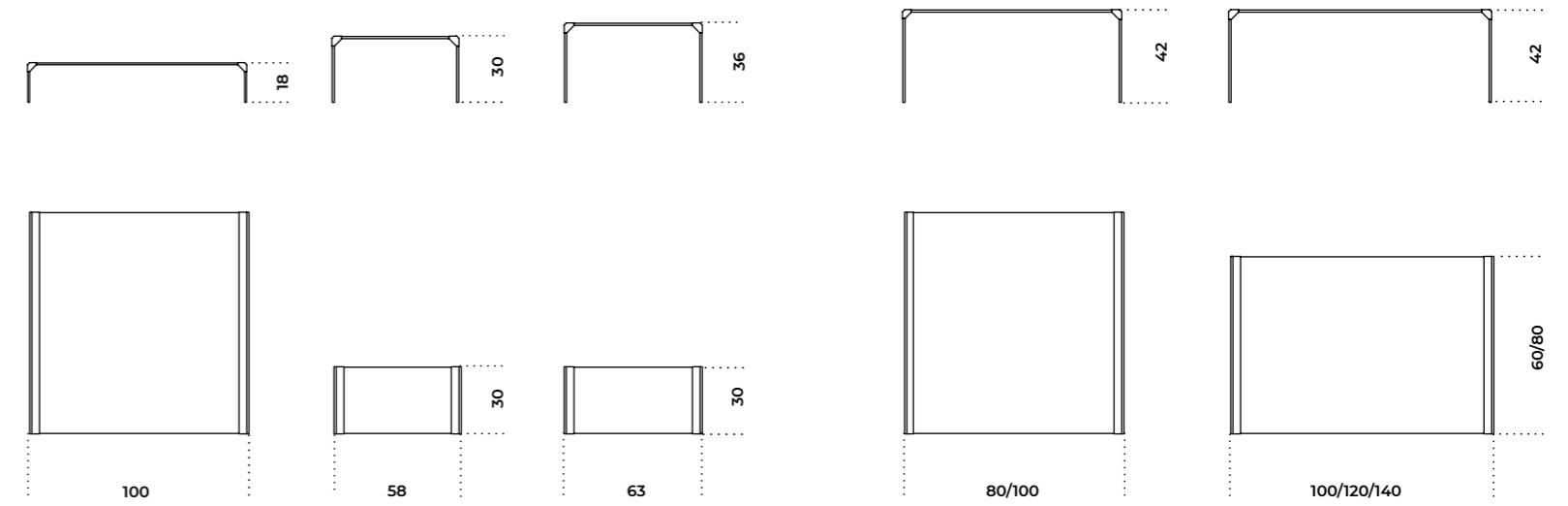

T35 R | Pierangelo Gallotti, 1975

Product information / p. 290

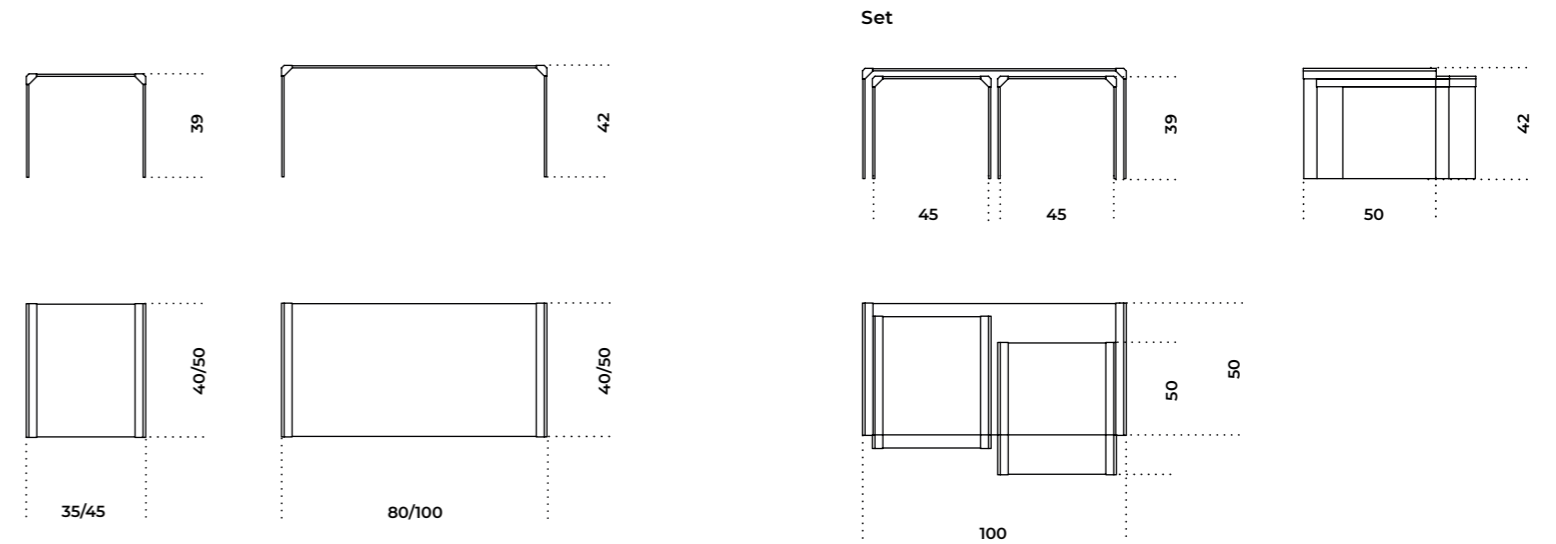

T35 Trio | Pierangelo Gallotti, 1975

Product information / p. 292

Trio

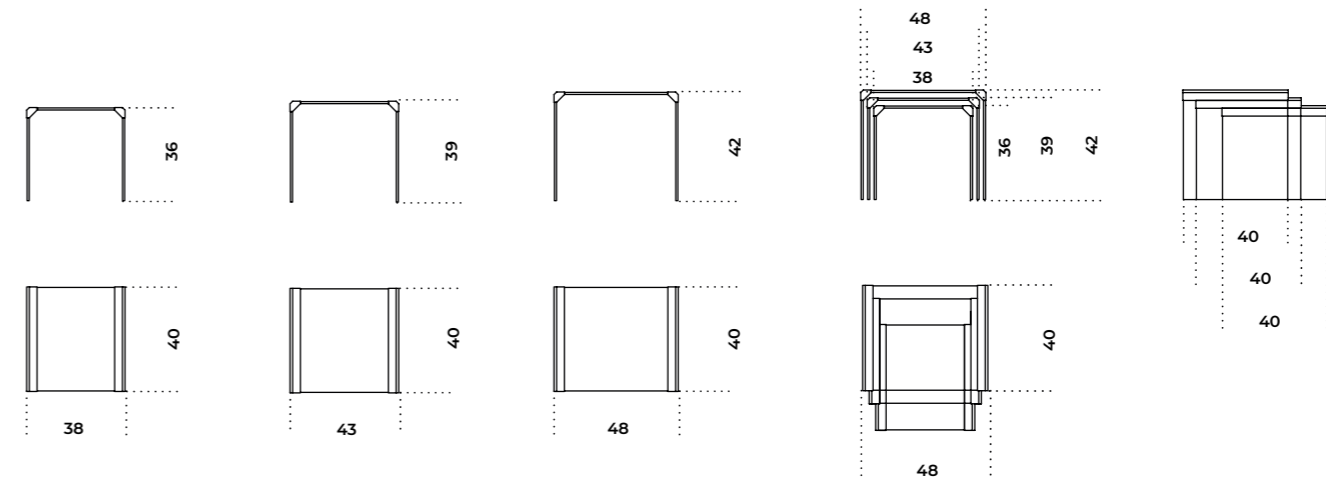

Tetris | Massimo Castagna, 2014

[Product information / p. 294](#)

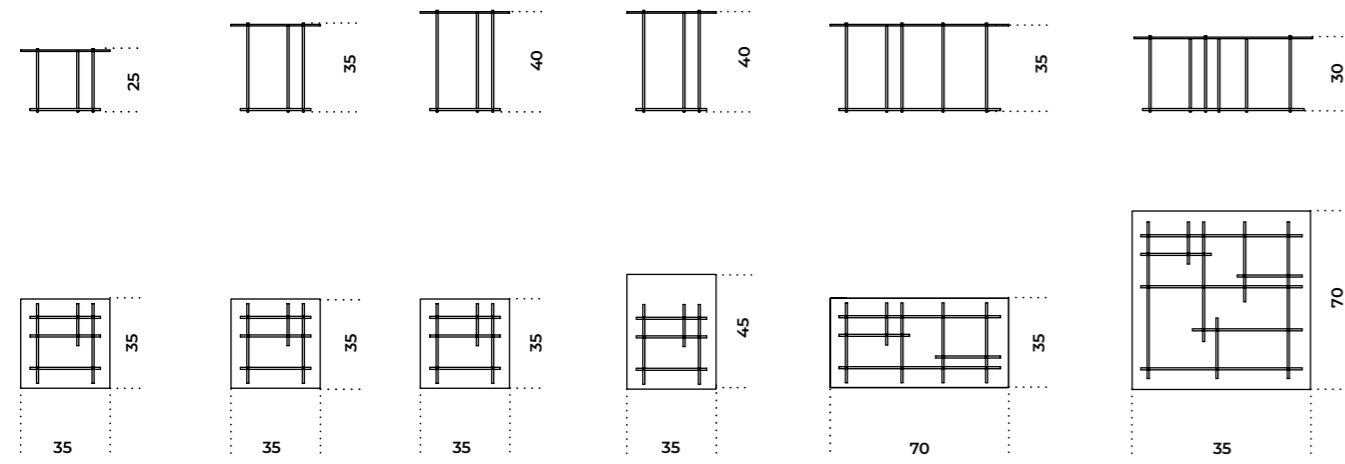

Zen Low | Massimo Castagna, 2018

[Product information / p. 300](#)

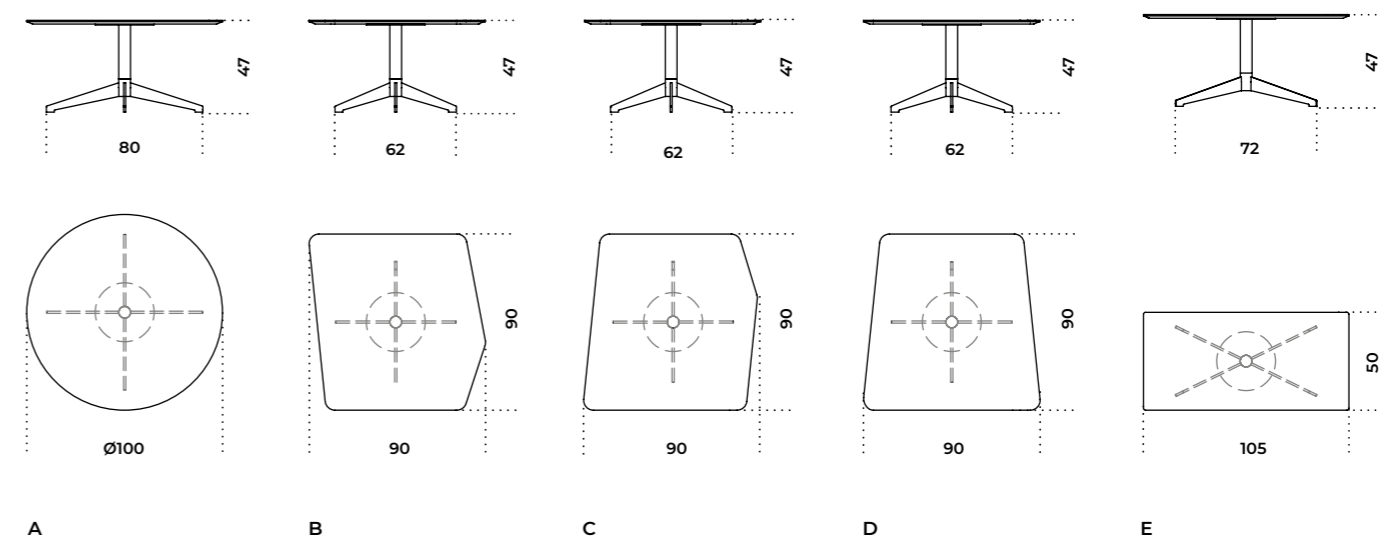

Twelve | Massimo Castagna, 2016

[Product information / p. 296](#)

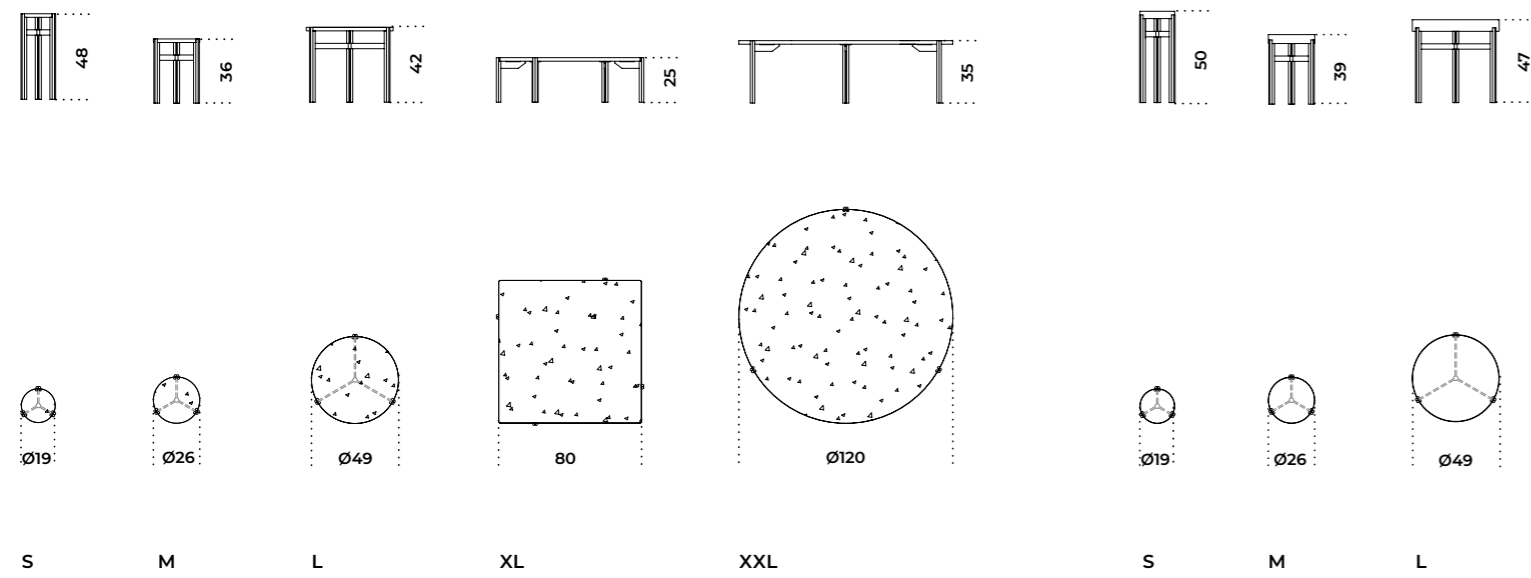

Zen Black Low | Massimo Castagna, 2020

[Product information / p. 298](#)

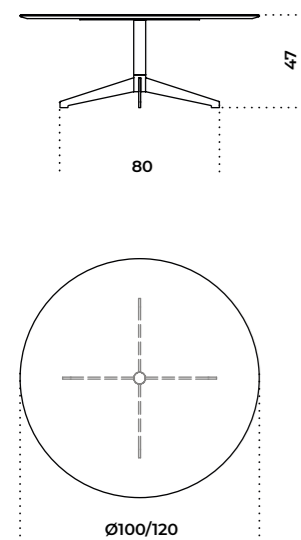

07 Console / Consoles

322 [Athus Console](#)

324 [DoIm Console](#)

326 [Hanami](#)

328 [Sensei Console](#)

330 [Tama Console](#)

332 [Informazioni tecniche/
Technical informations](#)

Athus Console

Oscar e Gabriele Buratti / 2013

Console in frassino tinto nero poro aperto. Top in cristallo 6mm temperato retroverniciato nero brillante. Disponibile anche verniciato nella finitura esclusiva spazzolata "Cashmere" nei colori gold grey o anthracite. Cassetti ad estrazione totale con fondo in pelle scamosciata sand 006.

NOTE TECNICHE SUI MATERIALI

CRISTALLO | Le finiture esclusive, risultato della lavorazione manuale realizzata sul cristallo, possono presentare striature e differenze cromatiche. Queste caratteristiche non devono essere considerate difetti ma elementi distintivi del processo artigianale che esaltano la bellezza e la peculiarità del pezzo unico.

Console in black open pore stained ash. 6mm bright black painted tempered glass top. Also available painted with the exclusive brushed "Cashmere" finish in the gold grey or anthracite colours. Total pull-out drawers with suede sand 006 bottom.

TECHNICAL INFORMATION ON THE MATERIALS

GLASS | Exclusive finishes, resulting from the craftsmanship on the glass, may show streaks and chromatic differences. These characteristics should not be considered imperfections but distinctive evidence of the hand-made process that enhance the beauty and peculiarity of the unique piece.



▲ **ATHUS CONSOLE**
Piano in cristallo retroverniciato nero brillante
Bright black painted glass top



Cm
150 x 46 x 80
180 x 46 x 80

Inches
59¼" x 18¼" x 31½"
71" x 18¼" x 31½"

[For technical drawing / p. 334](#)

[Pricelist 2023 / p. 223](#)
[Homescapes, sense of materials / p. 38](#)

STRUTTURA/STRUCTURE

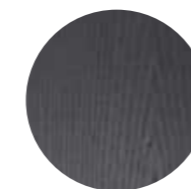

Frassino tinto
nero poro aperto
Black open pore
stained ash

PIANO/TOP

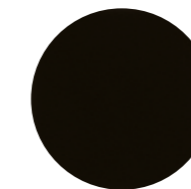

Cristallo retroverniciato
nero brillante
Bright black painted glass



Cristallo spazzolato
"Cashmere" gold grey
"Cashmere" gold grey
brushed glass



Cristallo spazzolato
"Cashmere" anthracite
"Cashmere" anthracite
brushed glass

FONDO CASSETTI/ DRAWERS BOTTOM



Pelle scamosciata
sand 006
Suede sand 006

Dolm Console

Oscar e Gabriele Buratti / 2013

Console con base in legno rivestito in cristallo 6mm temperato e con piano in appoggio in cristallo extralight 10mm temperato, retroverniciati nei colori del campionario, nella versione brillante o satinata. Disponibile versione verniciata nella finitura esclusiva spazzolata "Cashmere" gold grey e anthracite oppure bronzo patinato.

! L'azienda si riserva di scegliere il colore della trave in metallo coordinandola con la finitura del cristallo.

NOTE TECNICHE SUI MATERIALI

CRISTALLO | Le finiture esclusive, risultato della lavorazione manuale realizzata sul cristallo, possono presentare striature e differenze cromatiche. Queste caratteristiche non devono essere considerate difetti ma elementi distintivi del processo artigianale che esaltano la bellezza e la peculiarità del pezzo unico.

Console with wooden base covered by 6mm tempered glass and 10mm extralight tempered glass top, painted as per samples in the bright or version. Also available version with glass painted with the exclusive "Cashmere" brushed finish in the colours gold grey and anthracite or patinated bronze.

! The company reserves the right to choose the colour of the metal beam, matching it with the glass finish.

TECHNICAL INFORMATION ON THE MATERIALS

GLASS | Exclusive finishes, resulting from the craftsmanship on the glass, may show streaks and chromatic differences. These characteristics should not be considered imperfections but distinctive evidence of the hand-made process that enhance the beauty and peculiarity of the unique piece.



Cm

120 x 44 x 74
150 x 44 x 74
180 x 44 x 74

Inches

47¼" x 17½" x 29¼"
59¼" x 17½" x 29¼"
71" x 17½" x 29¼"

[For technical drawing / p. 334](#)

[Pricelist 2023 / p. 224](#)
[Homescapes, embracing beauty / p. 71](#)

▲ **DOLM CONSOLE**
Piano e base in cristallo retroverniciato nero satinato
Black satin glass painted top and base

BASE E PIANO/BASE AND TOP



Cristallo brillante/satinato nei colori del campionario
Glass bright/satin version as per samples



Cristallo spazzolato "Cashmere" gold grey
"Cashmere" gold grey brushed glass



Cristallo spazzolato "Cashmere" anthracite
"Cashmere" anthracite brushed glass

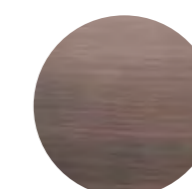

Cristallo verniciato bronzo patinato
Patinated bronze painted glass



▲ HANAMI
Struttura in legno laccato lucido "Rosso Persia"
"Rosso Persia" glossy lacquered wood structure

Hanami

Pietro Russo / 2022

Consolle in legno laccato opaco con piano in legno laccato lucido. Colori disponibili: "Rosso Persia", "Grigio Londra", "Nero Giza", "Bianco Camargue", "Verde Provenza", "Blu Pacifico", "Bordeaux Etruria" o "Rosa Jaipur". Piedini regolabili in ottone lucido. Su richiesta "Versione RAL" in legno laccato nel colore RAL richiesto dal cliente.

Console in opaque lacquered wood with glossy lacquered wooden top. Available colours: "Rosso Persia", "Grigio Londra", "Nero Giza", "Bianco Camargue", "Verde Provenza", "Blu Pacifico", "Bordeaux Etruria" or "Rosa Jaipur". Adjustable feet in bright brass. "RAL version" in RAL customer's lacquered wood on request.

! La "Versione RAL" prevede tempi di produzione diversi dallo standard che verranno confermati al momento dell'ordine.

! For "RAL Version" the production time is different and will be confirmed upon the order.

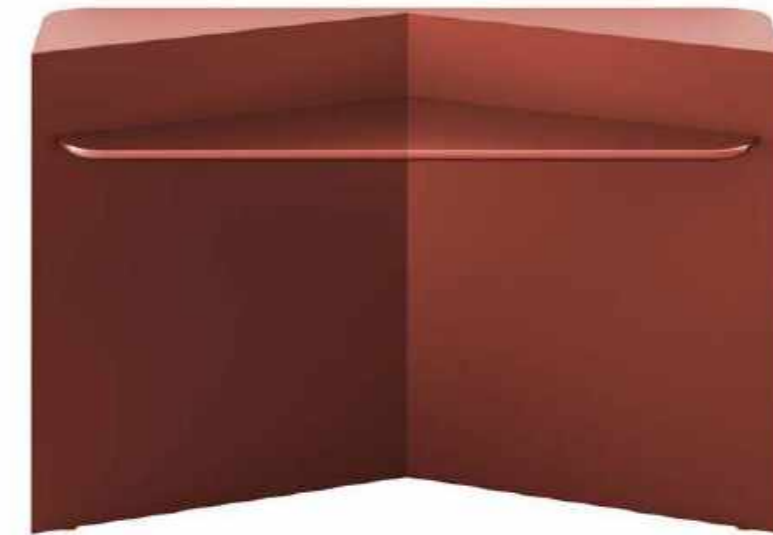

Cm

140 x 42 x 90
160 x 42 x 90

Inches

55¼" x 16¾" x 35½"
63" x 16¾" x 35½"

For technical drawing / p. 334

Pricelist 2023 / p. 225
Homescapes, gentle attitude / p. 69

STRUTTURA/STRUCTURE

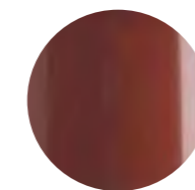

Legno laccato lucido
"Rosso Persia"
"Rosso Persia" glossy
lacquered wood

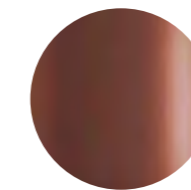

Legno laccato opaco
"Rosso Persia"
"Rosso Persia" opaque
lacquered wood



Legno laccato lucido
"grigio Londra"
"Grigio Londra" glossy
lacquered wood

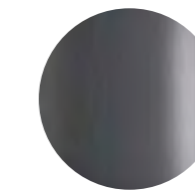

Legno laccato opaco
"grigio Londra"
"Grigio Londra" opaque
lacquered wood



Legno laccato lucido
"Nero Giza"
"Nero Giza" glossy
lacquered wood

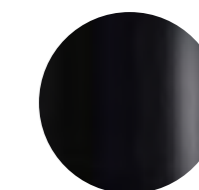

Legno laccato opaco
"Nero Giza"
"Nero Giza" opaque
lacquered wood

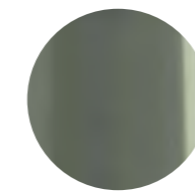

Legno laccato lucido
"Verde Provenza"
"Verde Provenza" glossy
lacquered wood



Legno laccato opaco
"Verde Provenza"
"Verde Provenza" opaque
lacquered wood

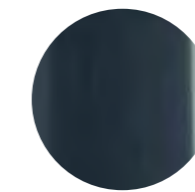

Legno laccato lucido
"Blu Pacifico"
"Blu Pacifico" glossy
lacquered wood

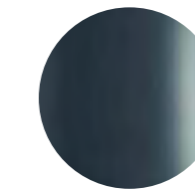

Legno laccato opaco "Blu Pacifico"
"Blu Pacifico" opaque
lacquered wood



Legno laccato lucido
"Bianco Camargue"
"Bianco Camargue" glossy
lacquered wood



Legno laccato opaco
"Bianco Camargue"
"Bianco Camargue"
opaque lacquered wood

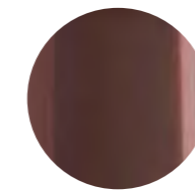

Legno laccato lucido
"Bordeaux Etruria"
"Bordeaux Etruria" glossy
lacquered wood

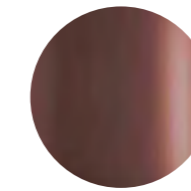

Legno laccato opaco
"Bordeaux Etruria"
"Bordeaux Etruria" opaque
lacquered wood



Legno laccato lucido
"Rosa Jaipur"
"Rosa Jaipur" glossy
lacquered wood

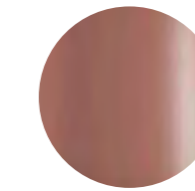

Legno laccato opaco
"Rosa Jaipur"
"Rosa Jaipur" opaque
lacquered wood

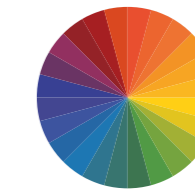

"Versione RAL"
"RAL Version"

Sensei Console

Tollgard+Castellani/2023

Consolle con struttura in metallo e piano in legno laccato "deep black". Ripiano e schienale in frassino tinto nero poro aperto. In appoggio sul top in legno, piano in cristallo 12mm molato a mezzo toro nella finitura esclusiva "Rosso Marte" oppure retroverniciato brillante nei colori del campionario. Disponibile anche piano in marmo 20mm Calacatta Vagli Oro lucido naturale, Ceppo di Gré® spazzolato, Arabescato Orobico Rosso satinato oppure Bianco Carrara Gioia spazzolato. Disponibile su richiesta versione lounge cm 65h. Su richiesta vassoio portaoggetti in metallo rivestito in pelle fard nei colori del campionario.

NOTE TECNICHE SUI MATERIALI

MARMO | Il marmo è un materiale naturale di origine sedimentaria che può presentare particolarità come venature, lievi irregolarità superficiali, colorazioni differenti e cristallizzazioni. Queste peculiarità sono da attribuirsi alla naturalezza del materiale e non sono da considerarsi difetti ma caratteristiche tipiche del marmo. Ogni prodotto risulterà unico, esclusivo e non replicabile. I nostri marmi vengono trattati con un prodotto idrorepellente che permette una maggiore protezione della superficie stessa, aumentando l'impermeabilità. Questo trattamento non esclude la vulnerabilità del marmo alle sostanze acide.

Console with "deep black" lacquered metal structure and wooden top. Black open pore stained ash shelf and back. Resting on the wooden top, 12mm glass top with half bull-nose grinding in the exclusive finish "Rosso Marte" or painted as per samples in the bright version. Also available with 20mm natural polished Calacatta Vagli Oro marble, brushed Ceppo di Gré®, satin Arabescato Orobico Rosso or brushed Bianco Carrara Gioia. Lounge version height cm 65, available on request. Metal accessories tray covered by leather fard as per samples, on request.

TECHNICAL INFORMATION ON THE MATERIALS

MARBLE | The marble is a natural material of sedimentary origin that can present particularities such as veins, slight surface irregularities, different colors and crystallizations. These peculiarities are to be attributed to the naturalness of the material and are not to be considered defects but typical characteristics of marble. Each product will be unique, exclusive and non-replicable. Our marbles are treated with water-repellent products which affords greater protection to the surface of the marble, improving its impermeability. This treatment doesn't exclude the vulnerability of the marble to acid substances.



Cm

Piano in cristallo

150 x 35 x 65

150 x 35 x 80

Piano in marmo

180 x 35 x 65

180 x 35 x 80

Vassoio portaoggetti

45 x 20 x 4

Inches

Glass top

59¼" x 14" x 25¾"

59¼" x 14" x 31½"

Marble top

71" x 14" x 25¾"

71" x 14" x 31½"

Accessories tray

17¾" x 8" x 1¾"

For technical drawing / p. 335

Pricelist 2023 / p. 226

STRUTTURA/STRUCTURE



Metallo laccato
"deep black"
"deep black" lacquered
metal

RIPIANO E SCHIENALE SHELF AND BACK

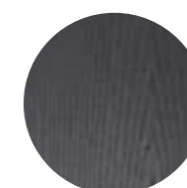

Frassino tinto
nero poro aperto
Black open pore
stained ash

PIANO/TOP



Cristallo "Rosso Marte"
"Rosso Marte" glass



Legno laccato
"deep black"
"deep black" lacquered
wood



Sample box

Cristallo brillante
nei colori del campionario
Bright glass version
as per samples



Marmo lucido naturale
Calacatta Vagli Oro
Natural polished Calacatta
Vagli Oro marble

VASSOIO PORTAOGGETTI ACCESSORIES TRAY



Sample box
COVERS

Metallo rivestito in pelle fard
nei colori del campionario
Metal covered leather fard
as per samples

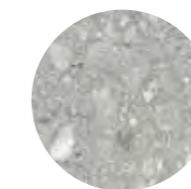

Ceppo di Gré® spazzolato
Brushed Ceppo di Gré®



Marmo Arabescato
Orobico Rosso satinato
Arabescato Orobico
Rosso satin marble



Marmo spazzolato
Bianco Carrara Gioia
Brushed Bianco Carrara
Gioia marble

▲ SENSEI CONSOLE

Piano in cristallo "RossoMarte"/ Vassoio portaoggetti in fard silt 2324
"Rosso Marte" glass top/ Fard silt 2324 accessories tray



Tama Console

Carlo Colombo / 2016

Console con cassetti in frassino tinto nero poro aperto con parti metalliche laccate ottone satinato. Top in cristallo 6mm temperato retroverniciato liquirizia brillante.

Console with black open pore stained ash drawers and satin brass lacquered metal parts. 6mm bright liquorice painted tempered glass top.



Cm
120 x 36 x 83
140 x 36 x 83

Inches
47 1/4" x 14 1/4" x 32 3/4"
55 1/4" x 14 1/4" x 32 3/4"

For technical drawing / p. 335

Pricelist 2023 / p. 227
Homescapes, sense of materials / p. 108

STRUTTURA/STRUCTURE

PIANO/TOP

PARTI METALLICHE/
METAL PARTS

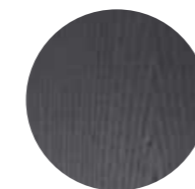

**Frassino tinto
nero poro aperto**
Black open pore
stained ash

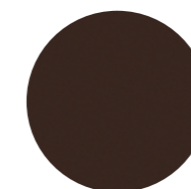

**Cristallo liquirizia
brillante**
Bright liquorice
painted glass



Ottone satinato
Satin brass

07

Consolle / Consoles
TECHNICAL MODULE

Athus Console | Oscar e Gabriele Buratti, 2013

Product information / p. 322

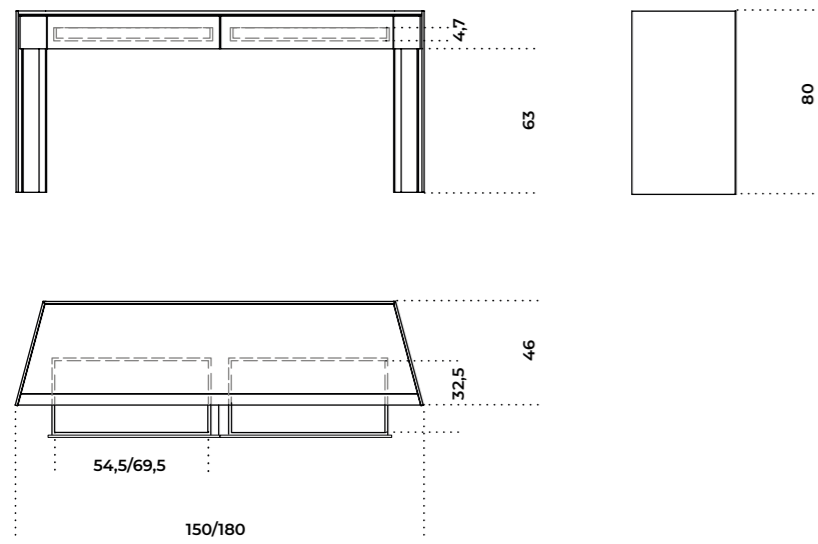

Sensei Console | Tollgard + Castellani, 2023

Product information / p. 328

Piano in cristallo
Glass top

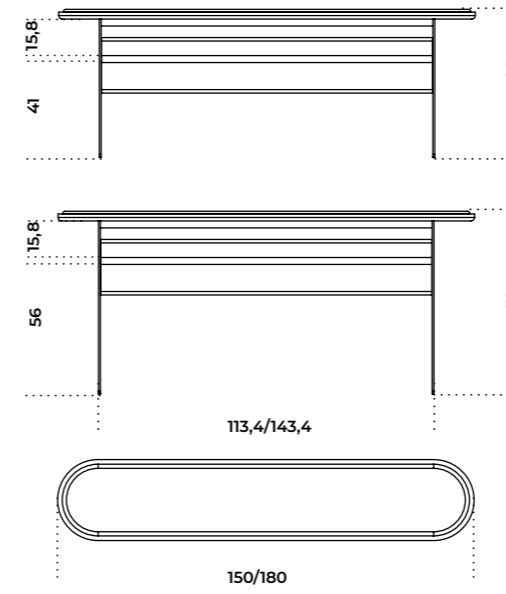

Piano in marmo
Marble top

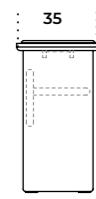
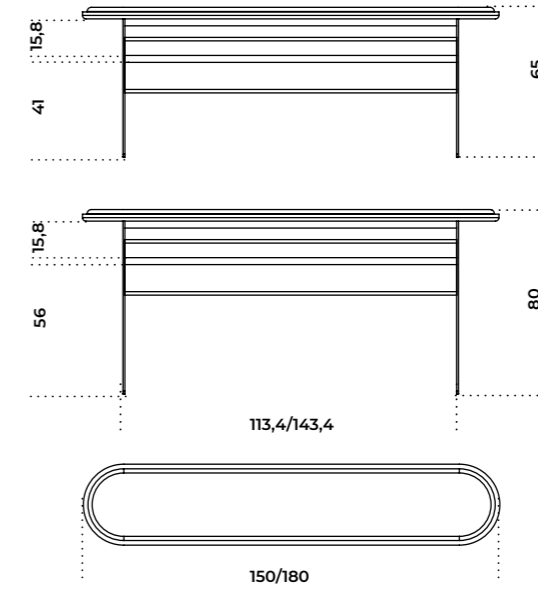

Vassoio portaoggetti
Accessories tray

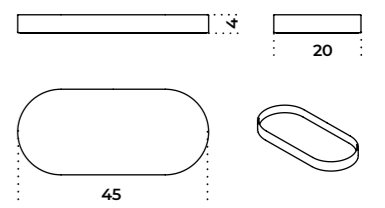

Dolm Console | Oscar e Gabriele Buratti, 2013

Product information / p. 324

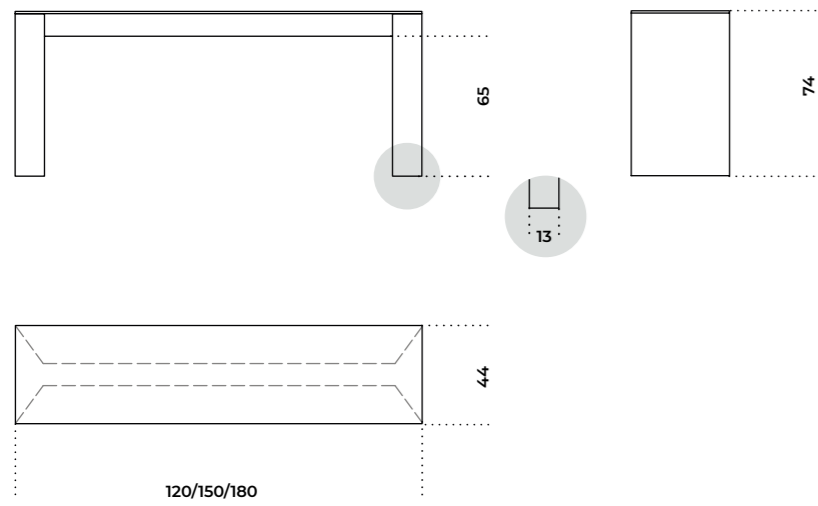

Tama Console | Carlo Colombo, 2016

Product information / p. 330

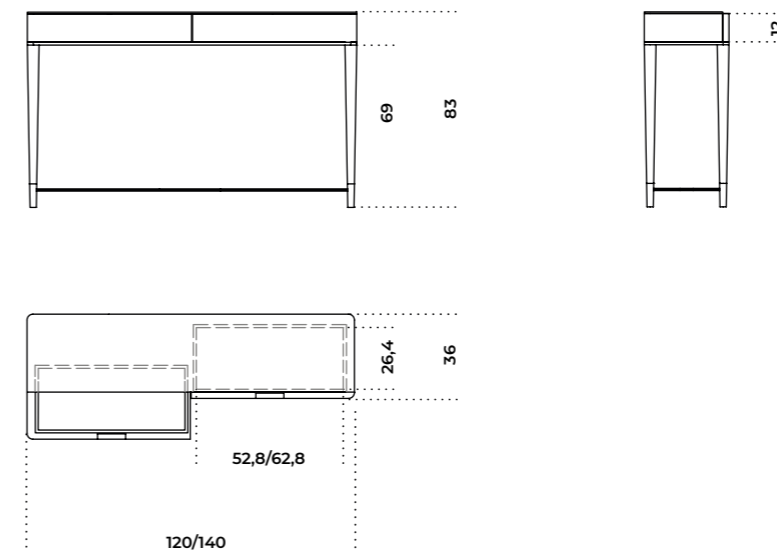

Hanami | Pietro Russo, 2022

Product information / p. 326

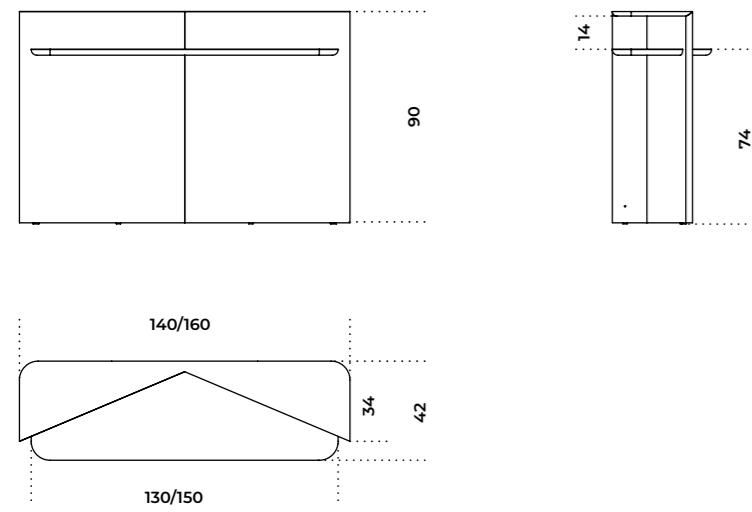

08 Contenitori / Storage Units

- [338](#) **5th Avenue**
- [340](#) **5th Avenue Crédence**
- [342](#) **Athus**
- [344](#) **Diedro**
- [346](#) **Gastone**
- [348](#) **Gastone Low**
- [350](#) **Hide&Seek**
- [354](#) **Kumi Credenza**
- [356](#) **Pandora**
- [358](#) **Pandora Cashmere**
- [360](#) **Pandora Craquelé**
- [362](#) **Pandora Light**
- [364](#) **Soda**
- [368](#) **Tama**
- [370](#) **Tama Crédence**
- [372](#) **Tama Vitrine**

- [374](#) **Informazioni tecniche/
Technical informations**

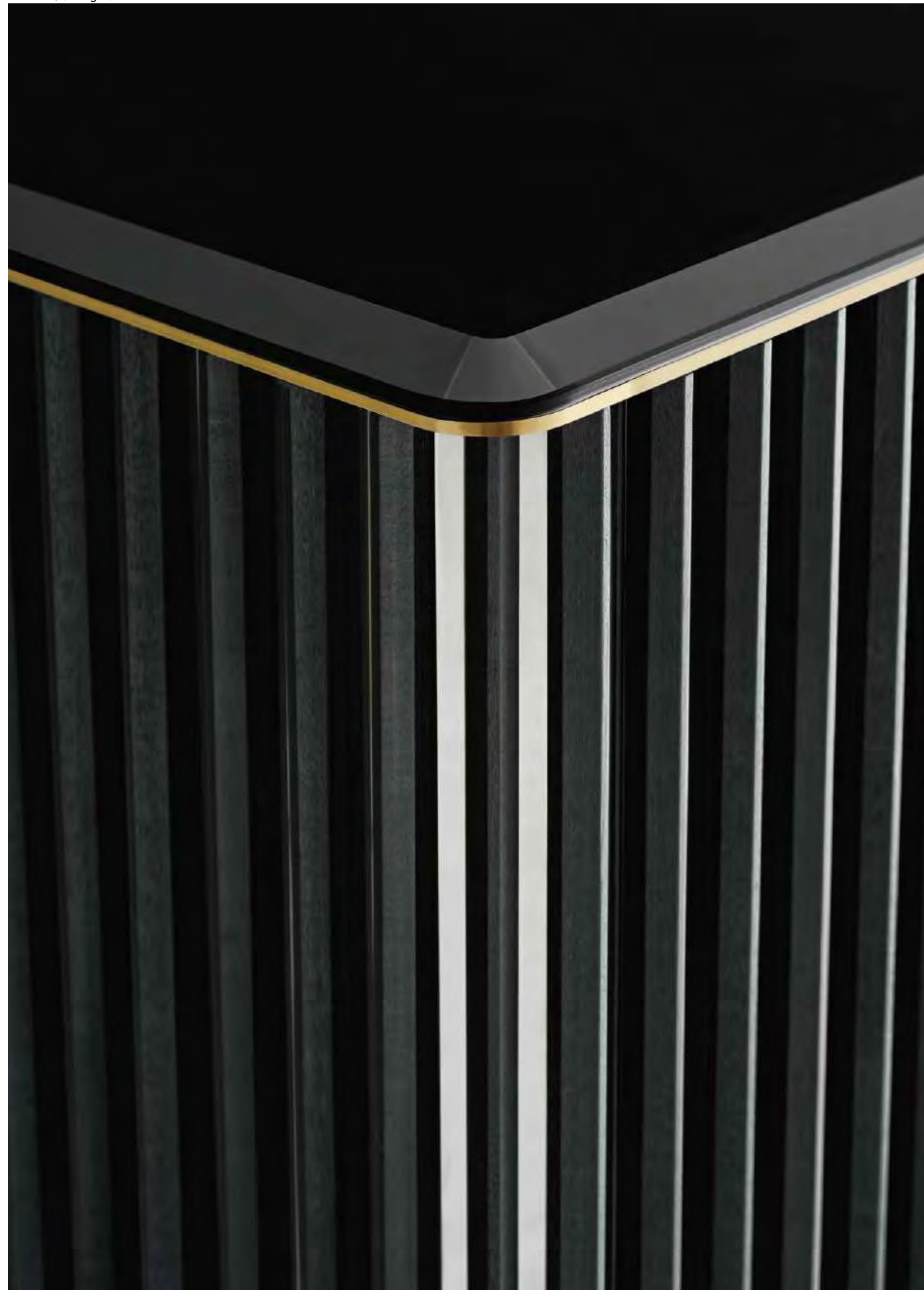

5th Avenue

Marcello Pozzi / 2019

Madia in legno rivestita in acciaio inox "supermirror" nella finitura cromo nero con listelli in massello tinto nero poro aperto. Base in frassino tinto nero poro aperto e rivestita internamente in acciaio inox "supermirror" nella finitura cromo nero. Top in cristallo "grigio Italia" 12 mm bisellato retroverniciato nero brillante con dettaglio in ottone satinato. Dotata di ripiano interno in cristallo extralight 8mm e schienale interno in specchio 6mm.

Wooden unit covered by "supermirror" stainless steel in the black chrome finish with black stained open pore solid wood strips. Base in black open pore stained ash and internal part covered by "supermirror" stainless steel in the black chrome finish. Top with bevel in 12mm bright black painted smoked "grigio Italia" glass with satin brass detail. Supplied with 8mm extralight glass shelf and 6mm mirrored glass inside back.

NOTE TECNICHE SUI MATERIALI

CRISTALLO | Le finiture esclusive, risultato della lavorazione manuale realizzata sul cristallo, possono presentare striature e differenze cromatiche. Queste caratteristiche non devono essere considerate difetti ma elementi distintivi del processo artigianale che esaltano la bellezza e la peculiarità del pezzo unico.

TECHNICAL INFORMATION ON THE MATERIALS

GLASS | Exclusive finishes, resulting from the craftsmanship on the glass, may show streaks and chromatic differences. These characteristics should not be considered imperfections but distinctive evidence of the hand-made process that enhance the beauty and peculiarity of the unique piece.



For technical drawing / p. 376

Cm
110 x 47 x 122

Inches
43½" x 18¾" x 48¾"

Pricelist 2023 / p. 241
Homescapes, sense of materials / p. 18
Homescapes, embracing beauty / p. 28
Homescapes, gentle attitude / p. 37

STRUTTURA E BASE/ STRUCTURE AND BASE

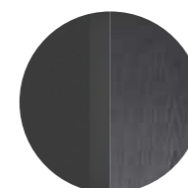

Cromo nero "supermirror"/
Tinto nero poro aperto
Black chrome "supermirror"/
Black open pore stained
ash

PIANO/TOP

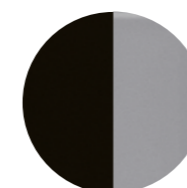

Cristallo "grigio Italia"
retroverniciato
nero brillante
Bright black painted
smoked "grigio Italia" glass

DETTAGLI/DETAILS



Ottone satinato
Satin brass

RIPIANO INTERNO / INSIDE SHELF



Cristallo extralight
Extralight glass

SCHIENALE INTERNO / INSIDE BACK



Specchio
Mirror

5th Avenue Crédence

Marcello Pozzi / 2020

Madia in legno rivestita in acciaio inox "supermirror" nella finitura cromo nero con listelli in massello tinto nero poro aperto. Base in frassino tinto nero poro aperto e rivestita internamente in acciaio inox "supermirror" nella finitura cromo nero. Top in cristallo "grigio Italia" 12mm bisellato retroverniciato nero brillante con dettaglio in ottone satinato. Schienale interno in specchio 6mm.
Configurazione standard con vani versione A (n. 2 vani per la misura cm 190 e n. 3 vani per la misura cm 280).
Possibilità di versione bifacciale con apertura delle ante fronte o retro, da specificare al momento dell'ordine.

Wooden unit covered by "supermirror" stainless steel in the black chrome finish with black stained open pore solid wood strips. Base in black open pore stained ash and internal part covered by "supermirror" stainless steel in the black chrome finish.
Top with bevel in 12mm bright black painted smoked "grigio Italia" glass with satin brass detail. 6mm mirrored glass inside back. Standard configuration with version A compartments (n. 2 compartments for the size cm 190 and n. 3 compartments for the size cm 280).
Double-sided version possible with front or rear doors opening, to be specified when ordering.



• 5TH AVENUE CRÉDENCE
Versione con vano interno A
Version with A compartment



Cm
190 x 47 x 74
280 x 47 x 74

Inches
75" x 18¾" x 29¼"
110¼" x 18¾" x 29¼"

[For technical drawing / p. 376](#)

[Pricelist 2023 / p. 242](#)
[Homescapes, embracing beauty / p. 25](#)
[Homescapes, gentle attitude / p. 39](#)

**STRUTTURA E BASE/
STRUCTURE AND BASE**

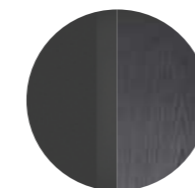

Cromo nero "supermirror"/
Tinto nero poro aperto
Black chrome "supermirror"/
Black open pore stained
ash

PIANO/TOP

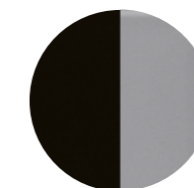

Cristallo "grigio Italia"
retroverniciato
nero brillante
Bright black painted
smoked "grigio Italia" glass

DETTAGLI/DETAILS



Ottone satinato
Satin brass

**RIPIANO INTERNO /
INSIDE SHELF**



Cristallo extralight
Extralight glass

**SCHIENALE INTERNO /
INSIDE BACK**

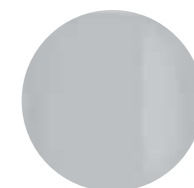

Specchio
Mirror



▲ **ATHUS**
Piano in marmo lucido naturale Stardust grey
Natural polished Stardust grey marble top

Athus

Oscar e Gabriele Buratti / 2017

Madia in frassino tinto nero poro aperto. Dettagli in metallo verniciato bronzo patinato. Top in marmo lucido naturale Stardust Grey o Sahara Noir. Disponibile anche in cristallo temperato 6mm retroverniciato nero brillante. Dotata di ripiano interno in cristallo extralight 10mm bisellato temperato. Schienali interni in specchio 6mm. Cassetti con fondo in pelle scamosciata e apertura push and pull solo per versioni 48h e 75,5h.

NOTE TECNICHE SUI MATERIALI

MARMO | Il marmo è un materiale naturale di origine sedimentaria che può presentare particolarità come venature, lievi irregolarità superficiali, colorazioni differenti e cristallizzazioni. Queste peculiarità sono da attribuirsi alla naturalezza del materiale e non sono da considerarsi difetti ma caratteristiche tipiche del marmo. Ogni prodotto risulterà unico, esclusivo e non replicabile. I nostri marmi vengono trattati con un prodotto idrorepellente che permette una maggiore protezione della superficie stessa, aumentando l'impermeabilità. Questo trattamento non esclude la vulnerabilità del marmo alle sostanze acide. Il marmo Sahara Noir viene trattato con vernice al poliestere per aumentare la resistenza del piano.

Sideboard in black open pore stained ash. Patinated bronze lacquered metal details. Natural polished Stardust Grey or Sahara Noir marble top. Also available in 6mm tempered bright black painted glass. Supplied with 10mm tempered and bevelled extralight inside glass shelf. 6mm mirror inside backs. Push-pull drawers with suede bottom just for versions 48h and 75,5h.

TECHNICAL INFORMATION ON THE MATERIALS

MARBLE | The marble is a natural material of sedimentary origin that can present particularities such as veins, slight surface irregularities, different colors and crystallizations. These peculiarities are to be attributed to the naturalness of the material and are not to be considered defects but typical characteristics of marble. Each product will be unique, exclusive and non-replicable. Our marbles are treated with water-repellent products which affords greater protection to the surface of the marble, improving its impermeability. This treatment doesn't exclude the vulnerability of the marble to acid substances. The Sahara Noir marble is treated with polyester-coated finish to increase the resistance of the top.



Cm

125,5 x 57 x 136,5
155 x 57 x 136,5
250 x 58 x 75,5
300 x 57 x 48

Inches

49½" x 22½" x 53¾"
61¼" x 22½" x 53¾"
98½" x 23" x 29¾"
118¼" x 22½" x 19"

For technical drawing / p. 377

Pricelist 2023 / p. 244
Homescapes, sense of materials / p. 54
Homescapes, intimate portraits / p. 39, 41

STRUTTURA/STRUCTURE



Frassino tinto
nero poro aperto
Black open pore
stained ash

DETTAGLI/DETAILS



Metallo verniciato
bronzo patinato
Patinated bronze
lacquered metal

PIANO/TOP



Marmo lucido naturale
Stardust grey
Natural polished
Stardust grey marble

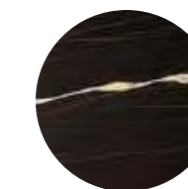

Marmo lucido naturale
Sahara Noir
Natural polished
Sahara Noir marble



Cristallo retroverniciato
nero brillante
Bright black painted glass

CASSETTI/DRAWERS VERSIONE 48 - 75,5 CM



Pelle scamosciata
Suede

Sample box
COVERS



Diedro

Pietro Russo / 2022

Contenitore pensile in frassino tinto nero poro aperto oppure legno laccato lucido o opaco. Colori disponibili: "Rosso Persia", "Grigio Londra", "Nero Giza", "Bianco Camargue", "Verde Provenza", "Blu Pacifico", "Bordeaux Etruria" o "Rosa Jaipur". Disponibile versione freestanding con struttura in metallo nero bronzato per il contenitore in frassino tinto nero o laccata nello stesso colore del contenitore per la versione laccata. Mobile altezza cm 120 dotato di due ripiani in cristallo extralight 8mm temperato.

Suspended unit in black open pore stained ash or glossy or opaque lacquered wood. Available colours: "Rosso Persia", "Grigio Londra", "Nero Giza", "Bianco Camargue", "Verde Provenza", "Blu Pacifico", "Bordeaux Etruria" or "Rosa Jaipur". Available freestanding version with bronzed black metal structure for the black stained ash unit or lacquered in the same colour of the unit for the lacquered version. Unit height cm 120 supplied with two 8mm tempered extralight glass shelves.



Cm	Inches
Versione freestanding	Freestanding version
131 x 47 x 153	51 3/4" x 18 3/4" x 60 3/4"
184 x 43 x 73	72 1/2" x 17" x 28 3/4"
305 x 43 x 73	120 1/4" x 17" x 28 3/4"
Versione pensile	Suspended version
131 x 47 x 120	51 3/4" x 18 3/4" x 47 1/4"
184 x 43 x 40	72 1/2" x 17" x 15 3/4"
305 x 43 x 40	120 1/4" x 17" x 15 3/4"
365.5 x 43 x 40	144" x 17" x 15 3/4"

For technical drawing / p. 377
 Pricelist 2023 / p. 245
 Homescapes, gentle attitude / pp. 81, 84, 85

VERSIONE PENSILE / SUSPENDED VERSION
 CONTENITORE LEGNO / WOODEN UNIT

Frassino tinto nero poro aperto Black open pore stained ash	Legno laccato lucido/opaco "Rosso Persia" "Rosso Persia" glossy /opaque lacquered wood	Legno laccato lucido/opaco "Grigio Londra" "Grigio Londra" glossy /opaque lacquered wood	Legno laccato lucido/opaco "Nero Giza" "Nero Giza" glossy/ opaque lacquered wood	Legno laccato lucido/opaco "Verde Provenza" "Verde Provenza" glossy/ opaque lacquered wood	Legno laccato lucido/opaco "Blu Pacifico" "Blu Pacifico" glossy/ opaque lacquered wood
Legno laccato lucido/opaco "Bianco Camargue" "Bianco Camargue" glossy/ opaque lacquered wood	Legno laccato lucido/opaco "Bordeaux Etruria" "Bordeaux Etruria" glossy/ opaque lacquered wood	Legno laccato lucido/opaco "Rosso Persia" "Rosso Persia" glossy/ opaque lacquered wood			

VERSIONE FREESTANDING / FREESTANDING VERSION
 CONTENITORE LEGNO / WOODEN UNIT

Frassino tinto nero poro aperto Black open pore stained ash	Metallo nero bronzato Bronzed black metal

STRUTTURA METALLO E CONTENITORE LEGNO / METAL STRUCTURE AND WOODEN UNIT

Laccato lucido/opaco "Rosso Persia" Glossy/opaque lacquered "Rosso Persia"	Laccato lucido/opaco "Grigio Londra" Glossy/opaque lacquered "Grigio Londra"	Laccato lucido/opaco "Nero Giza" Glossy/ opaque lacquered "Nero Giza"	Laccato lucido/opaco "Verde Provenza" Glossy/opaque lacquered "Verde Provenza"
Laccato lucido/opaco "Blu Pacifico" Glossy/opaque lacquered "Blu Pacifico"	Laccato lucido/opaco "Bianco Camargue" Glossy/ opaque lacquered "Bianco Camargue"	Laccato lucido/opaco "Bordeaux Etruria" Glossy/ opaque lacquered "Bordeaux Etruria"	Laccato lucido/opaco "Rosso Persia" Glossy/ opaque lacquered "Rosso Persia"

▲ DIEDRO WALL
 Struttura in laccato opaco RAL
 RAL lacquered matt structure

Gastone

Carlo Colombo / 2023

Madia in legno laccato lucido nei colori "Grigio Londra", "Nero Giza", "Bianco Camargue", "Verde Provenza", "Blu Pacifico", "Bordeaux Etruria" o "Rosa Jaipur". Parti interne color "grape must" (NCS S 5020-R10B). Top nella stessa finitura della madia. Su richiesta disponibile top in marmo Travertino Romano spazzolato naturale (non resinato) oppure in Ceppo di Gré® spazzolato. Su richiesta mensola superiore sagomata in cristallo extralight 8mm temperato. Il modulo ad ante può essere fornito con ripiano interno in cristallo extralight e il modulo cassettoni può essere fornito di cassetto interno. Disponibile in composizioni predefinite.

NOTE TECNICHE SUI MATERIALI

CEPPO DI GRÉ® - MARMO | Il marmo è un materiale naturale di origine sedimentaria che può presentare particolarità come venature, lievi irregolarità superficiali, colorazioni differenti e cristallizzazioni. Queste peculiarità sono da attribuirsi alla naturalezza del materiale e non sono da considerarsi difetti ma caratteristiche tipiche del marmo. Ogni prodotto risulterà unico, esclusivo e non replicabile. I nostri marmi vengono trattati con un prodotto idrorepellente che permette una maggiore protezione della superficie stessa, aumentando l'impermeabilità. Questo trattamento non esclude la vulnerabilità del marmo alle sostanze acide.

Sideboard in glossy lacquered wood. Available colours: "Rosso Persia", "Grigio Londra", "Nero Giza", "Bianco Camargue", "Verde Provenza", "Blu Pacifico", "Bordeaux Etruria" or "Rosa Jaipur". Internal part in "grape must" colour (NCS S 5020-R10B). Top in the same finish as the sideboard. Available, on request, natural brushed Travertino Romano (not treated with resin) or brushed Ceppo di Gré® top. Upon request 8mm extralight tempered shaped upper shelf. The module with doors can be supplied with an extralight glass internal shelf and the module with big drawer can be supplied with an internal drawer. Available in standard compositions.

TECHNICAL INFORMATION ON THE MATERIALS

CEPPO DI GRÉ® - MARBLE | The marble is a natural material of sedimentary origin that can present particularities such as veins, slight surface irregularities, different colors and crystallizations. These peculiarities are to be attributed to the naturalness of the material and are not to be considered defects but typical characteristics of marble. Each product will be unique, exclusive and non-replicable. Our marbles are treated with water-repellent products which affords greater protection to the surface of the marble, improving its impermeability. This treatment doesn't exclude the vulnerability of the marble to acid substances.



Cm
205 x 55 x 73,5
245 x 55 x 73,5

Inches
80¾" x 21¾" x 29"
96½" x 21¾" x 29"

For technical drawing / p. 378

Pricelist 2023 / p. 246

CONTENITORE/SIDEBOARD

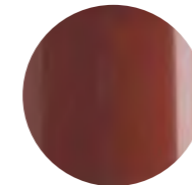

Legno laccato lucido
"Rosso Persia"
"Rosso Persia" glossy
lacquered wood

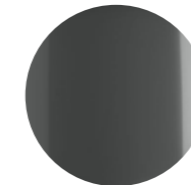

Legno laccato lucido
"grigio Londra"
"Grigio Londra" glossy
lacquered wood



Legno laccato lucido
"Nero Giza"
"Nero Giza" glossy
lacquered wood

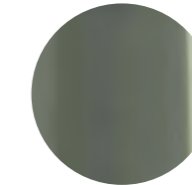

Legno laccato lucido
"Verde Provenza"
"Verde Provenza" glossy
lacquered wood

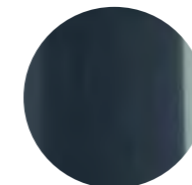

Legno laccato lucido
"Blu Pacifico"
"Blu Pacifico" glossy
lacquered wood



Legno laccato lucido
"Bianco Camargue"
"Bianco Camargue" glossy
lacquered wood

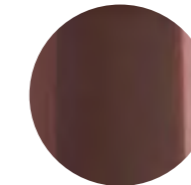

Legno laccato lucido
"Bordeaux Etruria"
"Bordeaux Etruria" glossy
lacquered wood



Legno laccato lucido
"Rosa Jaipur"
"Rosa Jaipur" glossy
lacquered wood

PARTI INTERNE/ INTERNAL PARTS



(NCS S 5020-R10B)
"Grape must"
"Grape must"

PIANO MARMO (OPZIONALE)/ MARBLE TOP (OPTIONAL)



Travertino Romano
spazzolato naturale
Natural brushed
Travertino Romano

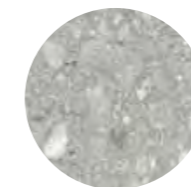

Ceppo di Gré® spazzolato
Brushed Ceppo di Gré®



Cristallo extralight
Extralight glass

MENSOLA SAGOMATA (OPZIONALE) SHAPED UPPER SHELF (OPTIONAL)

▲ GASTONE

Struttura in legno laccato lucido "Bordeaux Etruria", mensola in cristallo extralight
"Bordeaux Etruria" glossy lacquered wood structure, extralight glass upper shelf

Gastone Low

Carlo Colombo / 2023

Mobile contenitore in legno laccato lucido nei colori "Grigio Londra", "Nero Giza", "Bianco Camargue", "Verde Provenza", "Blu Pacifico", "Bordeaux Etruria" o "Rosa Jaipur". Appoggio a terra su base regolabile. Parti interne color "grape must" (NCS S 5020-R10B). Top nella stessa finitura della madia. Su richiesta disponibile top in marmo Travertino Romano spazzolato naturale (non resinato) oppure in Ceppo di Gré® spazzolato. Su richiesta mensola superiore sagomata in cristallo extralight 8mm temperato. Il modulo ad ante può essere fornito con ripiano interno in cristallo extralight e il modulo cassettoni può essere fornito di cassetto interno. Disponibile in composizioni predefinite.

NOTE TECNICHE SUI MATERIALI

CEPPO DI GRÉ® - MARMO | Il marmo è un materiale naturale di origine sedimentaria che può presentare particolarità come venature, lievi irregolarità superficiali, colorazioni differenti e cristallizzazioni. Queste peculiarità sono da attribuirsi alla naturalezza del materiale e non sono da considerarsi difetti ma caratteristiche tipiche del marmo. Ogni prodotto risulterà unico, esclusivo e non replicabile. I nostri marmi vengono trattati con un prodotto idrorepellente che permette una maggiore protezione della superficie stessa, aumentando l'impermeabilità. Questo trattamento non esclude la vulnerabilità del marmo alle sostanze acide.

Sideboard in glossy lacquered wood. Available colours: "Rosso Persia", "Grigio Londra", "Nero Giza", "Bianco Camargue", "Verde Provenza", "Blu Pacifico", "Bordeaux Etruria" or "Rosa Jaipur". Floor base support on adjustable base. Internal part in "grape must" colour (NCS S 5020-R10B). Top in the same finish as the sideboard. Available, on request, natural brushed Travertino Romano (not treated with resin) or brushed Ceppo di Gré® top. Upon request 8mm extralight tempered shaped upper shelf. The module with doors can be supplied with an extralight glass internal shelf and the module with big drawer can be supplied with an internal drawer. Available in standard compositions.

TECHNICAL INFORMATION ON THE MATERIALS

CEPPO DI GRÉ® - MARBLE | The marble is a natural material of sedimentary origin that can present particularities such as veins, slight surface irregularities, different colors and crystallizations. These peculiarities are to be attributed to the naturalness of the material and are not to be considered defects but typical characteristics of marble. Each product will be unique, exclusive and non-replicable. Our marbles are treated with water-repellent products which affords greater protection to the surface of the marble, improving its impermeability. This treatment doesn't exclude the vulnerability of the marble to acid substances.



Cm

205 x 55 x 57
245 x 55 x 57
406 x 55 x 57
446 x 55 x 57
486 x 55 x 57

Inches

80 3/4" x 21 3/4" x 22 1/2"
96 1/2" x 21 3/4" x 22 1/2"
160" x 21 3/4" x 22 1/2"
175 1/4" x 21 3/4" x 22 1/2"
191 1/2" x 21 3/4" x 22 1/2"

For technical drawing / p. 379-383

Pricelist 2023 / p. 248

CONTENITORE/SIDEBOARD

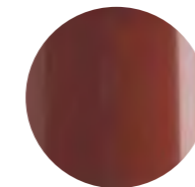

Legno laccato lucido
"Rosso Persia"
"Rosso Persia" glossy
lacquered wood

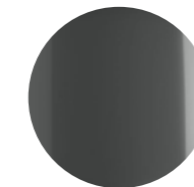

Legno laccato lucido
"grigio Londra"
"Grigio Londra" glossy
lacquered wood



Legno laccato lucido
"Nero Giza"
"Nero Giza" glossy
lacquered wood

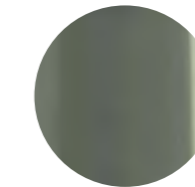

Legno laccato lucido
"Verde Provenza"
"Verde Provenza" glossy
lacquered wood

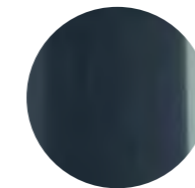

Legno laccato lucido
"Blu Pacifico"
"Blu Pacifico" glossy
lacquered wood

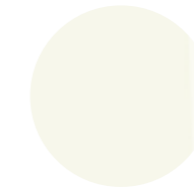

Legno laccato lucido
"Bianco Camargue"
"Bianco Camargue" glossy
lacquered wood

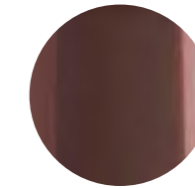

Legno laccato lucido
"Bordeaux Etruria"
"Bordeaux Etruria" glossy
lacquered wood



Legno laccato lucido
"Rosa Jaipur"
"Rosa Jaipur" glossy
lacquered wood

PIANO MARMO (OPZIONALE)/ MARBLE TOP (OPTIONAL)



Travertino Romano
spazzolato naturale
Natural brushed
Travertino Romano

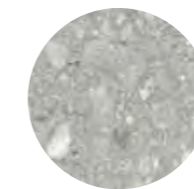

Ceppo di Gré® spazzolato
Brushed Ceppo di Gré®



Cristallo extralight
Extralight glass

PARTI INTERNE/ INTERNAL PARTS



(NCS S 5020-R10B)
"Grape must"
"Grape must"



▲ HIDE&SEEK
Struttura in legno laccato lucido "Rosso Persia"
"Rosso Persia" glossy lacquered wood structure

Hide&Seek

Pietro Russo / 2021

Contenitore con struttura, ripiani e mezzi-cilindri in legno laccato lucido o opaco. Colori disponibili: "Rosso Persia", "Grigio Londra", "Nero Giza", "Bianco Camargue", "Verde Provenza", "Blu Pacifico", "Bordeaux Etruria" o "Rosa Jaipur". Mezzi-cilindri con apertura bifacciale. Disponibile versione con cilindri girevoli, in posizioni prestabilite, che permettono la chiusura dei vani. Dettagli in ottone satinato.

Sideboard with structure, shelves and half-cylinder in glossy or opaque lacquered wood. Available colours: "Rosso Persia", "Grigio Londra", "Nero Giza", "Bianco Camargue", "Verde Provenza" o "Blu Pacifico". Half-cylinder with front or rear opening. Available version with rotating cylinders, in pre-established positions, which allows the closing of the compartments. Satin brass details



Cm

150 x 50 x 85
150 x 50 x 125
150 x 50 x 165
250 x 50 x 61

Inches

59½" x 19¾" x 33½"
59½" x 19¾" x 49½"
59½" x 19¾" x 65"
98½" x 19¾" x 24½"

For technical drawing / p. 383

Pricelist 2023 / p. 252
Homescapes, intimate portraits / p. 40, 106
Homescapes, gentle attitude / pp. 73, 75

STRUTTURA, RIPIANI E MEZZI CILINDRI/STRUCTURE, SHELVES AND HALF-CYLINDER

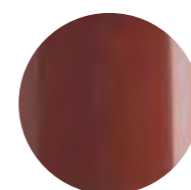

Legno laccato lucido
"Rosso Persia"
"Rosso Persia" glossy
lacquered wood

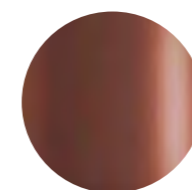

Legno laccato opaco
"Rosso Persia"
"Rosso Persia" opaque
lacquered wood



Legno laccato lucido
"Grigio Londra"
"Grigio Londra" glossy
lacquered wood

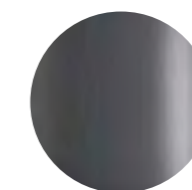

Legno laccato opaco "Grigio Londra"
"Grigio Londra" opaque
lacquered wood



Legno laccato lucido
"Nero Giza"
"Nero Giza" glossy
lacquered wood

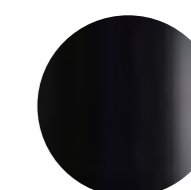

Legno laccato opaco
"Nero Giza"
"Nero Giza" opaque
lacquered wood

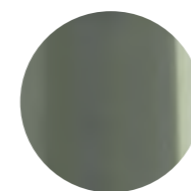

Legno laccato lucido
"Verde Provenza"
"Verde Provenza" glossy
lacquered wood

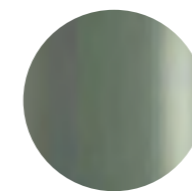

Legno laccato opaco
"Verde Provenza"
"Verde Provenza" opaque
lacquered wood

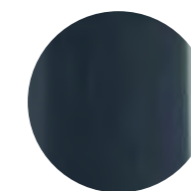

Legno laccato lucido
"Blu Pacifico"
"Blu Pacifico" glossy
lacquered wood

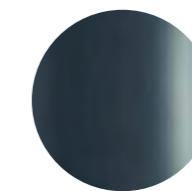

Legno laccato opaco "Blu Pacifico"
"Blu Pacifico" opaque
lacquered wood

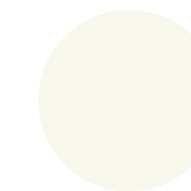

Legno laccato lucido
"Bianco Camargue"
"Bianco Camargue" glossy
lacquered wood



Legno laccato opaco
"Bianco Camargue"
"Bianco Camargue" opaque
lacquered wood

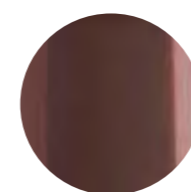

Legno laccato lucido
"Bordeaux Etruria"
"Bordeaux Etruria" glossy
lacquered wood

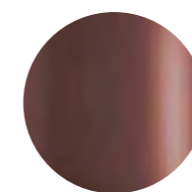

Legno laccato opaco
"Bordeaux Etruria"
"Bordeaux Etruria" opaque
lacquered wood

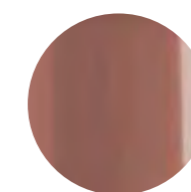

Legno laccato lucido
"Rosa Jaipur"
"Rosa Jaipur" glossy
lacquered wood

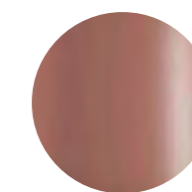

Legno laccato opaco
"Rosa Jaipur"
"Rosa Jaipur" opaque
lacquered wood



Ottone satinato
Satin brass

DETTAGLI/DETAILS

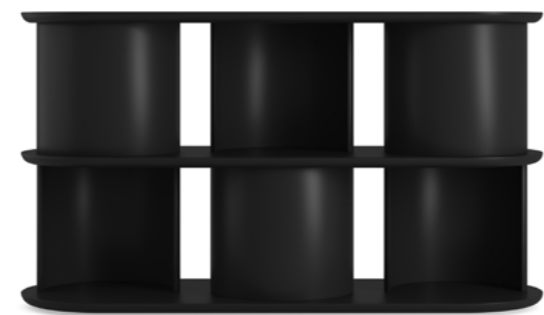



▲ KUMI CREDENZA
Piano in marmo lucido naturale Verde Alpi
Natural polished Verde Alpi marble top

Kumi Credenza

Carlo Colombo / 2020

Mobile giorno con ante, cassetti e vano a giorno. Disponibile versione h110 con ante laterali, cassetti e vano a ribalta con schienale interno specchiato 6mm. Dotata di luce interna LED attivata da un sensore all'apertura dell'anta. Struttura in legno tinto nero poro aperto, rivestita frontalmente e lateralmente con fascia zigrinata a mano. Vani con anta dotati di ripiano in legno. Piano disponibile in marmo bisellato lucido naturale Calacatta Vagli Oro, Verde Alpi, Arabescato Orobico Rosso satinato oppure cristallo temperato 6mm retroverniciato nero brillante. Maniglie e parti metalliche in metallo laccato color fango.

NOTE TECNICHE SUI MATERIALI

MARMO | Il marmo è un materiale naturale di origine sedimentaria che può presentare particolarità come venature, lievi irregolarità superficiali, colorazioni differenti e cristallizzazioni. Queste peculiarità sono da attribuirsi alla naturalezza del materiale e non sono da considerarsi difetti ma caratteristiche tipiche del marmo. Ogni prodotto risulterà unico, esclusivo e non replicabile. I nostri marmi vengono trattati con un prodotto idrorepellente che permette una maggiore protezione della superficie stessa, aumentando l'impermeabilità. Questo trattamento non esclude la vulnerabilità del marmo alle sostanze acide.

Sideboard with doors, drawers and open module. Also available h110 version with side doors, drawers and unit with flap door with 6mm inside mirrored back. Supplied with inside LED light turned on by sensor as flap door is opened. Structure in black stained open pore wood. Front and sides clad with hand knurled border. Modules with doors supplied with inside wooden shelf. Top available in bevelled natural polished Calacatta Vagli Oro, natural polished Verde Alpi, satin Arabescato Orobico Rosso marble or 6mm thick tempered bright black painted glass. Handles and metal parts lacquered in the "fango" colour.

TECHNICAL INFORMATION ON THE MATERIALS

MARBLE | The marble is a natural material of sedimentary origin that can present particularities such as veins, slight surface irregularities, different colors and crystallizations. These peculiarities are to be attributed to the naturalness of the material and are not to be considered defects but typical characteristics of marble. Each product will be unique, exclusive and non-replicable. Our marbles are treated with water-repellent products which affords greater protection to the surface of the marble, improving its impermeability. This treatment doesn't exclude the vulnerability of the marble to acid substances.



Cm

143 x 50 x 75
194 x 50 x 75
143 x 50 x 110

Inches

56½" x 19¾" x 29¾"
76½" x 19¾" x 29¾"
56½" x 19¾" x 43½"

[For technical drawing / p. 384](#)

[Pricelist 2023 / p. 253](#)
[Homescapes, embracig beauty / p. 22](#)

STRUTTURA/STRUCTURE

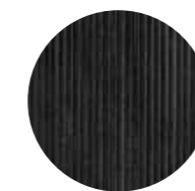

Legno tinto nero poro aperto
Black open pore stained wood

VERSIONE PIANO MARMO/MARBLE TOP VERSION



Marmo lucido naturale Calacatta Vagli Oro
Natural polished Calacatta Vagli Oro marble



Marmo lucido naturale Verde Alpi
Natural polished Verde Alpi marble



Marmo Arabescato Orobico Rosso satinato
Arabescato Orobico Rosso satin marble

VERSIONE PIANO CRISTALLO/ GLASS TOP VERSION

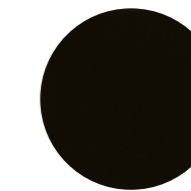

Cristallo retroverniciato nero brillante
Bright black painted glass

PARTI METALLICHE/ METAL PARTS

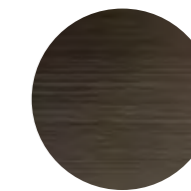

Metallo laccato "fango"
Metal lacquered "fango"

VERSIONE H.110/ H.110 VERSION

SCHIENALE INTERNO/ INSIDE BACK



Specchio
Mirror

LUCE INTERNA/ INSIDE LIGHT

LED 15W
108 lm
3000K
Cable length: 1,5mt



▲ **PANDORA**
 Esterno in foglia oro ossidata / Interno in foglia oro con ripiano in cristallo extralight
 Oxidated gold leaf outside / Gold leaf inside with 8mm extralight glass shelves

Pandora

Pinuccio Borgonovo / 2014

Madia in cristallo 8mm extralight temperato, rivestito in foglia oro applicata con lavorazione manuale ed esclusiva. Grazie a questo trattamento, il contenitore assume una colorazione disomogenea e unica all'esterno e mantiene la finitura dorata all'interno. Dotata di ripiani in cristallo 8mm extralight temperato. Struttura e maniglie in metallo verniciate bronzo patinato. Piani in legno rivestiti in foglia oro. Collezione in edizione numerata.

NOTE TECNICHE SUI MATERIALI

FINITURE ARTIGIANALI | Le finiture manuali ed esclusive, risultato del processo di ossidazione di foglia argento, oro e rame, possono presentare macchie e striature, oltre a differenze cromatiche. Tali disomogeneità sono caratteristiche che non devono essere considerate difetti ma elementi distintivi, tipici dell'ossidazione manuale, che esaltano la bellezza e la peculiarità del pezzo unico.

Sideboard in 8mm extralight tempered glass covered by gold leaf applied by hand with an exclusive treatment. Thanks to this process the unit has an irregular and unique finish outside and a gold finish inside. Supplied with 8mm extralight tempered glass shelves. Patinated bronze lacquered metal structure and handles. Wooden tops covered by gold leaf. Collection in numbered edition.

TECHNICAL INFORMATION ON THE MATERIALS

ARTISANAL FINISHES | Artisanal and exclusive finishes that are obtained from the oxidation of silver, gold and copper leaves may show marks and spots, as well as variations in colour. These differences are inevitable and should not be considered imperfections but evidence of the hand-crafted process. They enhance the beauty and distinctiveness of a unique piece.



Cm

162 x 52 x 71
 162 x 52 x 100
 162 x 52 x 126
 202 x 52 x 71

Inches

64" x 20½" x 28"
 64" x 20½" x 39½"
 64" x 20½" x 49¾"
 79¾" x 20½" x 28"

[For technical drawing / p. 384](#)

[Pricelist 2023 / p. 254](#)
[Homescapes, gentle attitude / pp. 28, 29](#)

STRUTTURA/STRUCTURE

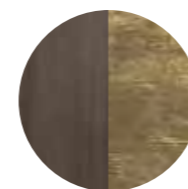

Esterno - foglia oro ossidata
Interno - foglia oro
 Outside - oxidated gold leaf
 Inside - gold leaf

BASE E MANIGLIE/BASE AND HANDLES



Metallo verniciato bronzo patinato
 Patinated bronze lacquered

RIPIANI/SHELVES



Cristallo extralight
 Extralight glass



Pandora Cashmere

Pinuccio Borgonovo / 2020

Madia in cristallo 8mm extralight temperato, verniciato nella finitura esclusiva spazzolata "Cashmere" nei colori gold grey o anthracite. Interno retroverniciato nero brillante. Dotata di ripiani in cristallo 8mm extralight temperato. Struttura e maniglie, in metallo e base, in legno, verniciati bronzo patinato. Collezione in edizione numerata.

Sideboard in 8mm tempered extralight glass painted with the exclusive "Cashmere" brushed finish in the colours gold grey or anthracite. Bright black painted inside. Supplied with 8mm extralight tempered glass shelves. Patinated bronze lacquered metal structure, handles and wooden base. Collection in numbered edition.

NOTE TECNICHE SUI MATERIALI

CRISTALLO | Le finiture esclusive, risultato della lavorazione manuale realizzata sul cristallo, possono presentare striature e differenze cromatiche. Queste caratteristiche non devono essere considerate difetti ma elementi distintivi del processo artigianale che esaltano la bellezza e la peculiarità del pezzo unico.

TECHNICAL INFORMATION ON THE MATERIALS

GLASS | Exclusive finishes, resulting from the craftsmanship on the glass, may show streaks and chromatic differences. These characteristics should not be considered imperfections but distinctive evidence of the hand-made process that enhance the beauty and peculiarity of the unique piece.



Cm

162 x 52 x 71
162 x 52 x 100
162 x 52 x 126
202 x 52 x 71

Inches

64" x 20½" x 28"
64" x 20½" x 39½"
64" x 20½" x 49¾"
79¾" x 20½" x 28"

For technical drawing / p. 385

Pricelist 2023 / p. 255
Homescapes, intimate portraits/ p. 78, 81

STRUTTURA/STRUCTURE

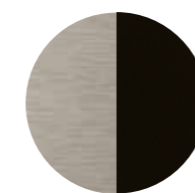

Esterno- cristallo
"Cashmere" gold grey/
Interno- cristallo nero
brillante
Outside- "Cashmere" gold
grey glass/
Inside- Bright black glass

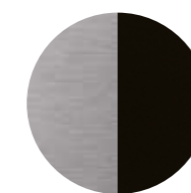

Esterno- cristallo
"Cashmere" anthracite/
Interno- cristallo nero
brillante
Outside- "Cashmere"
anthracite glass/
Inside- Bright black glass

BASE E MANIGLIE/ BASE AND HANDLES



Metallo verniciato
bronzo patinato
Patinated bronze
lacquered

RIPIANI/SHELVES



Cristallo extralight
Extralight glass

Pandora Craquelé

Pinuccio Borgonovo / 2016

Madia in cristallo 8mm extralight temperato, decorato con lavorazione manuale ed esclusiva. Interno retroverniciato bronzo brillante. Dotata di ripiani in cristallo 8mm extralight temperato. Struttura e maniglie, in metallo e base, in legno, verniciati bronzo patinato. Collezione in edizione numerata.

Sideboard in 8mm tempered extralight glass decorated by hand with exclusive treatment. Bright bronze painted inside. Supplied with 8mm extralight tempered glass shelves. Patinated bronze lacquered metal structure, handles and wooden base. Collection in numbered edition.

NOTE TECNICHE SUI MATERIALI

CRISTALLO | Le finiture esclusive, risultato della lavorazione manuale realizzata sul cristallo, possono presentare striature e differenze cromatiche. Queste caratteristiche non devono essere considerate difetti ma elementi distintivi del processo artigianale che esaltano la bellezza e la peculiarità del pezzo unico.

TECHNICAL INFORMATION ON THE MATERIALS

GLASS | Exclusive finishes, resulting from the craftsmanship on the glass, may show streaks and chromatic differences. These characteristics should not be considered imperfections but distinctive evidence of the hand-made process that enhance the beauty and peculiarity of the unique piece.



Cm

162 x 52 x 71
162 x 52 x 100
162 x 52 x 126
202 x 52 x 71

Inches

64" x 20½" x 28"
64" x 20½" x 39½"
64" x 20½" x 49¾"
79¾" x 20½" x 28"

[For technical drawing / p. 385](#)

[Pricelist 2023 / p. 256](#)

STRUTTURA/STRUCTURE



**Esterno - cristallo Craquelé/
Interno - cristallo bronzo
brillante**
Outside - Craquelé glass/
Inside - bright bronze glass

BASE E MANIGLIE BASE AND HANDLES



**Metallo verniciato
bronzo patinato**
Patinated bronze
lacquered

RIPIANI/SHELVES



Cristallo extralight
Extralight glass



▲ PANDORA LIGHT
 Dettaglio piano inferiore in marmo spazzolato Emperor Brown
 Brushed Emperor Brown marble bottom shelf detail

Pandora Light

Pinuccio Borgonovo / 2016

Madia in cristallo 8mm extralight temperato con top in cristallo 8mm verniciato bronzo patinato. Dotata di ripiani in cristallo 8mm extralight temperato. Struttura e maniglie in metallo verniciate bronzo patinato. Piano inferiore in legno rivestito in foglia oro oppure in marmo Emperor Brown spazzolato. Disponibile versione con schienale in cristallo e piano inferiore in legno verniciati bronzo patinato. Collezione in edizione numerata.

Sideboard in 8mm extralight tempered glass with 8mm patinated bronze painted glass top. Supplied with 8mm extralight tempered glass shelves. Patinated bronze lacquered metal structure and handles. Wooden bottom shelf covered by gold leaf or brushed Emperor Brown marble. Also available version with patinated bronze lacquered glass back and wooden bottom shelf. Collection in numbered edition.

NOTE TECNICHE SUI MATERIALI

CRISTALLO | Le finiture esclusive, risultato della lavorazione manuale realizzata sul cristallo, possono presentare striature e differenze cromatiche. Queste caratteristiche non devono essere considerate difetti ma elementi distintivi del processo artigianale che esaltano la bellezza e la peculiarità del pezzo unico.

MARMO | Il marmo è un materiale naturale di origine sedimentaria che può presentare particolarità come venature, lievi irregolarità superficiali, colorazioni differenti e cristallizzazioni. Queste peculiarità sono da attribuirsi alla naturalezza del materiale e non sono da considerarsi difetti ma caratteristiche tipiche del marmo. Ogni prodotto risulterà unico, esclusivo e non replicabile.

TECHNICAL INFORMATION ON THE MATERIALS

GLASS | Exclusive finishes, resulting from the craftsmanship on the glass, may show streaks and chromatic differences. These characteristics should not be considered imperfections but distinctive evidence of the hand-made process that enhance the beauty and peculiarity of the unique piece.

MARBLE | The marble is a natural material of sedimentary origin that can present particularities such as veins, slight surface irregularities, different colors and crystallizations. These peculiarities are to be attributed to the naturalness of the material and are not to be considered defects but typical characteristics of marble. Each product will be unique, exclusive and non-replicable.



Cm

162 x 52 x 71
 162 x 52 x 100
 162 x 52 x 126
 202 x 52 x 71

Inches

64" x 20½" x 28"
 64" x 20½" x 39½"
 64" x 20½" x 49¾"
 79¾" x 20½" x 28"

For technical drawing / p. 385

Pricelist 2023 / p. 257
 Homescapes, sense of materials / p. 32

STRUTTURA/STRUCTURE	TOP	MANIGLIE E PARTI METALLICHE/HANDLES AND METAL PARTS	RIPIANI E SCHIENALE/ SHELVES AND BACK	PIANO INFERIORE/BOTTOM SHELF	
					
Cristallo extralight Extralight glass	Cristallo verniciato bronzo patinato Patinated bronze painted glass	Metallo verniciato bronzo patinato Patinated bronze lacquered metal	Cristallo extralight Extralight glass	Legno rivestito foglia oro Gold leaf wood covered	Marmo spazzolato Emperor Brown Brushed Emperor Brown marble
NEW VERSION 2022 STRUTTURA/STRUCTURE	TOP E SCHIENALE/ TOP AND BACK	MANIGLIE E PARTI METALLICHE/HANDLES AND METAL PARTS	RIPIANI/SHELVES	PIANO INFERIORE/ BOTTOM SHELF	
					
Cristallo extralight Extralight glass	Cristallo verniciato bronzo patinato Patinated bronze painted glass	Metallo verniciato bronzo patinato Patinated bronze lacquered metal	Cristallo extralight Extralight glass	Legno verniciato bronzo patinato Patinated bronze lacquered wood	



Soda

Draga & Aurel / 2022

Vetrina con struttura in legno laccato color "elephant grey" e anta in cristallo fuso 6mm temperato verniciato color ambra. Disponibile versione con struttura in legno frassino tinto nero poro aperto e anta in cristallo fuso 6mm temperato "grigio Italia". Entrambe con schienale e ripiani in cristallo "grigio Italia" 6mm temperato. Dettagli in ottone satinato.

Sideboard with "elephant grey" lacquered wooden structure and 6mm molten tempered glass lacquered amber color door. Also available version with black open pore stained ash structure and 6mm molten tempered glass "grigio Italia" door. Both version with back and shelves in 6mm tempered smoked "grigio Italia" glass. Details in satin brass.



Cm
120 x 46 x 165

Inches
47¼" x 18¼" x 65"

[For technical drawing / p. 386](#)

[Pricelist 2023 / p. 258](#)
[Homescapes, gentle attitude / pp. 48, 92, 93, 96, 97](#)

STRUTTURA/STRUCTURE

ANTE/DOOR

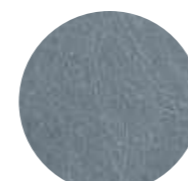

Legno laccato
"elephant grey"
"Elephant grey"
lacquered wood



Cristallo fusotemperato
verniciato ambra
Molten tempered glass
lacquered amber color

STRUTTURA/STRUCTURE

ANTE/DOOR

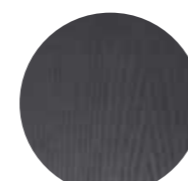

Frassino tinto
nero poro aperto
Black open pore
stained ash



Cristallo fuso temperato
"grigio Italia"
Molten tempered glass
"grigio Italia"

SCHIENALE E RIPIANI BACK AND SHELVES



Cristallo "grigio Italia"
"Grigio Italia" glass

SCHIENALE E RIPIANI BACK AND SHELVES



Cristallo "grigio Italia"
"Grigio Italia" glass

DETTAGLI/DETAILS



Ottone satinato
Satin brass

DETTAGLI/DETAILS



Ottone satinato
Satin brass



• SODA

Struttura in legno frassino tinto nero poro aperto e anta in cristallo fuso temperato "grigio Italia"/Schienale e ripiani in cristallo "grigio Italia"
Black open pore stained ash structure and molten tempered glass "grigio Italia" door/Back and shelves tempered smoked "grigio Italia" glass.





Tama

Carlo Colombo / 2015

Mobile bar in frassino tinto nero poro aperto con parti metalliche laccato ottone satinato. Interno rivestito in specchio 5mm "grigio Italia" inciso. Ripiano interno in cristallo "grigio Italia" 8mm temperato. Dotata di luce interna LED attivata da un sensore all'apertura delle ante.

Black open pore stained ash wooden bar unit and satin brass lacquered metal parts. Inside covered by 5mm engraved smoked "grigio Italia" mirror. Supplied with 8mm tempered smoked "grigio Italia" glass shelf. Supplied with inside LED light turned on by sensor as doors are opened.



Cm
70 x 40 x 141,5

Inches
27 3/4" x 15 3/4" x 55 3/4"

[For technical drawing / p. 386](#)

[Pricelist 2023 / p. 259](#)

STRUTTURA/STRUCTURE

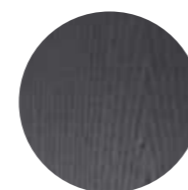

Frassino tinto nero poro aperto
Black open pore stained ash

PARTI METALLICHE/METAL PARTS



Ottone satinato
Satin brass

INTERNO/INSIDE



Specchio "grigio Italia" con incisione a rombi
Smoked "grigio Italia" mirror with rhomboidal engraved pattern

RIPIANO INTERNO/INSIDE SHELF



Cristallo "grigio Italia"
"Grigio Italia" glass

LUCE INTERNA/INSIDE LIGHT

LED 15W
108 lm
3000K
Cable length: 1,5mt

Tama Crédence

Carlo Colombo / 2016

Madia in frassino tinto nero poro aperto con parti metalliche laccate ottone satinato. Top in cristallo temperato 6mm e schienale interno in cristallo 6mm entrambi retroverniciati liquirizia brillante. Sullo schienale interno incisione a rombi. Ripiani interni in cristallo "grigio Italia" 8mm temperato e vassoi portaoggetti in legno. Dotata di luce interna LED attivata da un sensore all'apertura delle ante.

Sideboard in black open pore stained ash with satin brass lacquered metal parts. 6mm tempered glass top and 6mm inside back both bright liquorice painted. Rhomboidal engraved pattern on the inside glass back. Supplied with 8mm tempered smoked "grigio Italia" glass shelf and wooden trays. Supplied with inside LED light turned on by sensor as doors are opened.



Cm
240 x 48 x 72

Inches
94½" x 19" x 28½"

[For technical drawing / p.387](#)

[Pricelist 2023 / p.260](#)
[Homescapes, gentle attitude / pp. 86, 87](#)

STRUTTURA/STRUCTURE

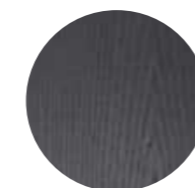

Frassino tinto
nero poro aperto
Black open pore
stained ash

PARTI METALLICHE/ METAL PARTS



Ottone satinato
Satin brass

PIANO/TOP

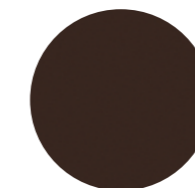

Cristallo retroverniciato
liquirizia brillante
Bright liquorice
painted glass

SCHIENALE INTERNO/ INSIDE BACK



Cristallo retroverniciato
liquirizia brillante con
incisione a rombi
Bright liquorice painted
glass with rhomboidal
engraved pattern

RIPIANO INTERNO/ INSIDE SHELF



Cristallo "grigio Italia"
"Grigio Italia" glass

LUCE INTERNA/ INSIDE LIGHT

LED 15W
108 lm
3000K
Cable lenght: 1,5mt



Tama Vitrine

Carlo Colombo / 2020

Madia in frassino tinto nero poro aperto. Parti metalliche laccate ottone satinato. Top in cristallo temperato 6mm e schienale interno in cristallo 6mm entrambi retroverniciati liquirizia brillante. Sullo schienale interno incisione a rombi. Dotata di ripiani in cristallo "grigio Italia" 8mm. Anta centrale in cristallo 4mm e alluminio color bronzo. Dotata di luce interna LED attivata da un sensore all'apertura delle ante.

NOTE TECNICHE SUI MATERIALI

CRISTALLO | Le finiture esclusive, risultato della lavorazione manuale realizzata sul cristallo, possono presentare striature e differenze cromatiche. Queste caratteristiche non devono essere considerate difetti ma elementi distintivi del processo artigianale che esaltano la bellezza e la peculiarità del pezzo unico.

Sideboard in black open pore stained ash. Satin brass lacquered metal parts. 6mm tempered glass top and 6mm inside back both bright liquorice painted. Rhomboidal engraved pattern on the inside glass back. Supplied with 8mm tempered smoked "grigio Italia" glass shelves. Central door in 4mm glass and aluminium in the colour bronze. Supplied with inside LED light turned on by sensor as doors are opened.

TECHNICAL INFORMATION ON THE MATERIALS

GLASS | Exclusive finishes, resulting from the craftsmanship on the glass, may show streaks and chromatic differences. These characteristics should not be considered imperfections but distinctive evidence of the hand-made process that enhance the beauty and peculiarity of the unique piece.



Cm
125 x 49 x 131

Inches
49¼" x 19½" x 51¾"

For technical drawing / p. 387

Pricelist 2023 / p. 261

STRUTTURA/STRUCTURE

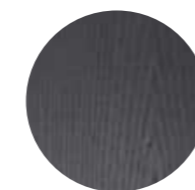

Frassino tinto
nero poro aperto
Black open pore
stained ash

PARTI METALLICHE/ METAL PARTS



Ottone satinato
Satin brass

ANTA CENTRALE/ CENTRAL DOOR

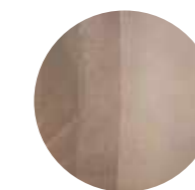

Cristallo/Alluminio
color bronzo
Glass/Aluminium
colour bronze

PIANO/TOP

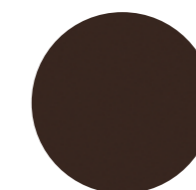

Cristallo retroverniciato
liquirizia brillante
Bright liquorice
painted glass

SCHIENALE INTERNO/ INSIDE BACK



Cristallo retroverniciato
liquirizia brillante con
incisione a rombi
Bright liquorice painted
glass with rhomboidal
engraved pattern

RIPIANO INTERNO/ INSIDE SHELF



Cristallo "grigio Italia"
"Grigio Italia" glass

LUCE INTERNA/ INSIDE LIGHT

LED 15W
108 lm
3000K
Cable length: 1,5mt

08

Contenitori / Storage Units
TECHNICAL MODULE

5th Avenue | Marcello Pozzi, 2019

Product information / p. 338

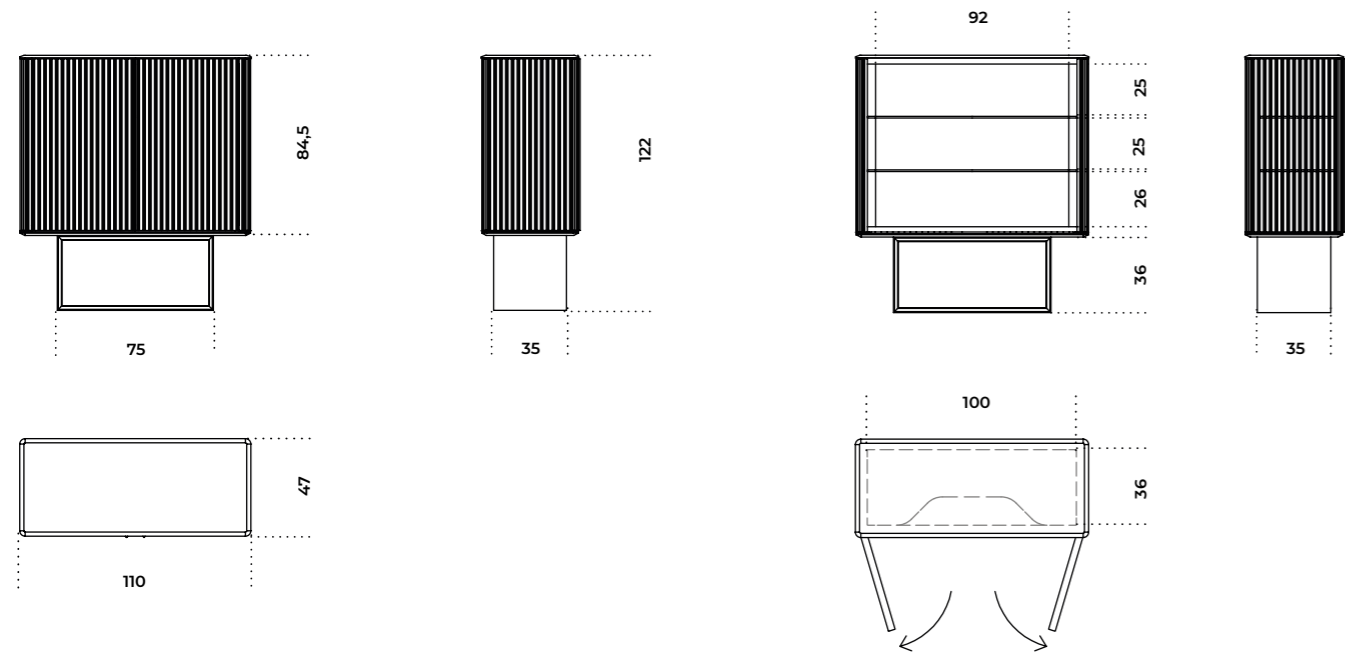

5th Avenue Crédence | Marcello Pozzi, 2020

Product information / p. 340

Versione 2 moduli A
Version with 2 modules A

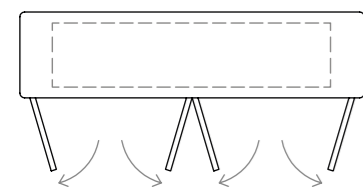
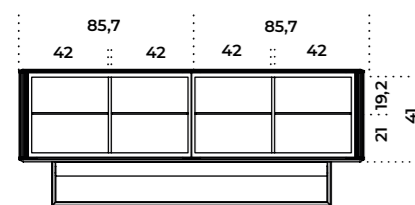
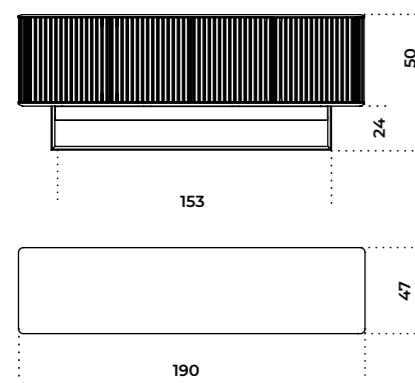

Vano versione A / Version A

n.2 ripiani in cristallo extralight
n. 2 extralight glass shelves

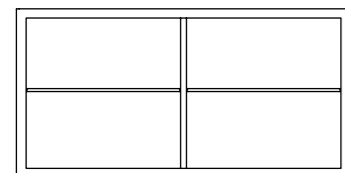

Versione 3 moduli A
Version with 3 modules A

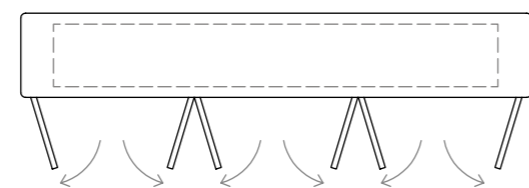
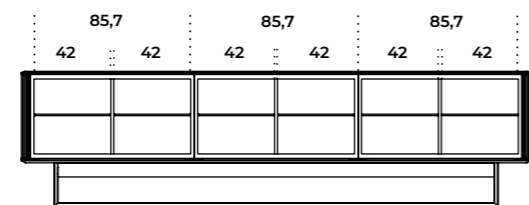
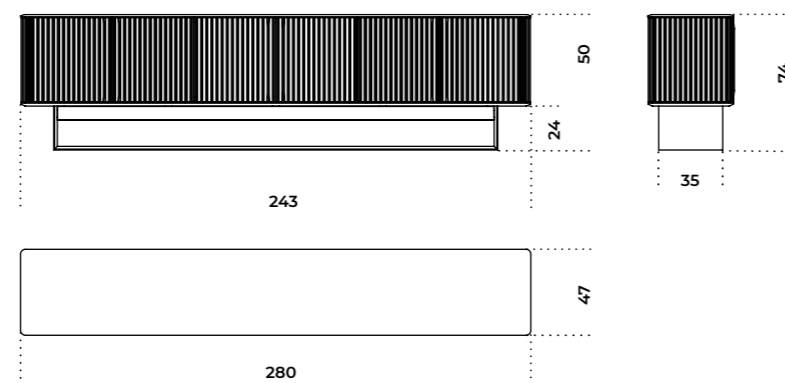

Vano versione B / Version B

n.2 ripiani in cristallo extralight +
n.1 vano centrale
n. 2 extralight glass shelves +
n. 1 central compartment

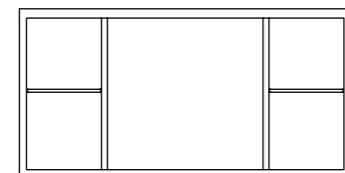

Vano versione C / Version C

n.4 ripiani in cristallo extralight +
n.4 vassoi in frassino tinto nero poro aperto
n. 4 extralight glass shelves +
n. 4 black open pore stained ash wooden tray

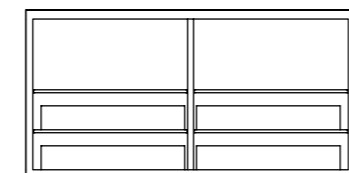

Athus | Oscar e Gabriele Buratti, 2017

Product information / p. 342

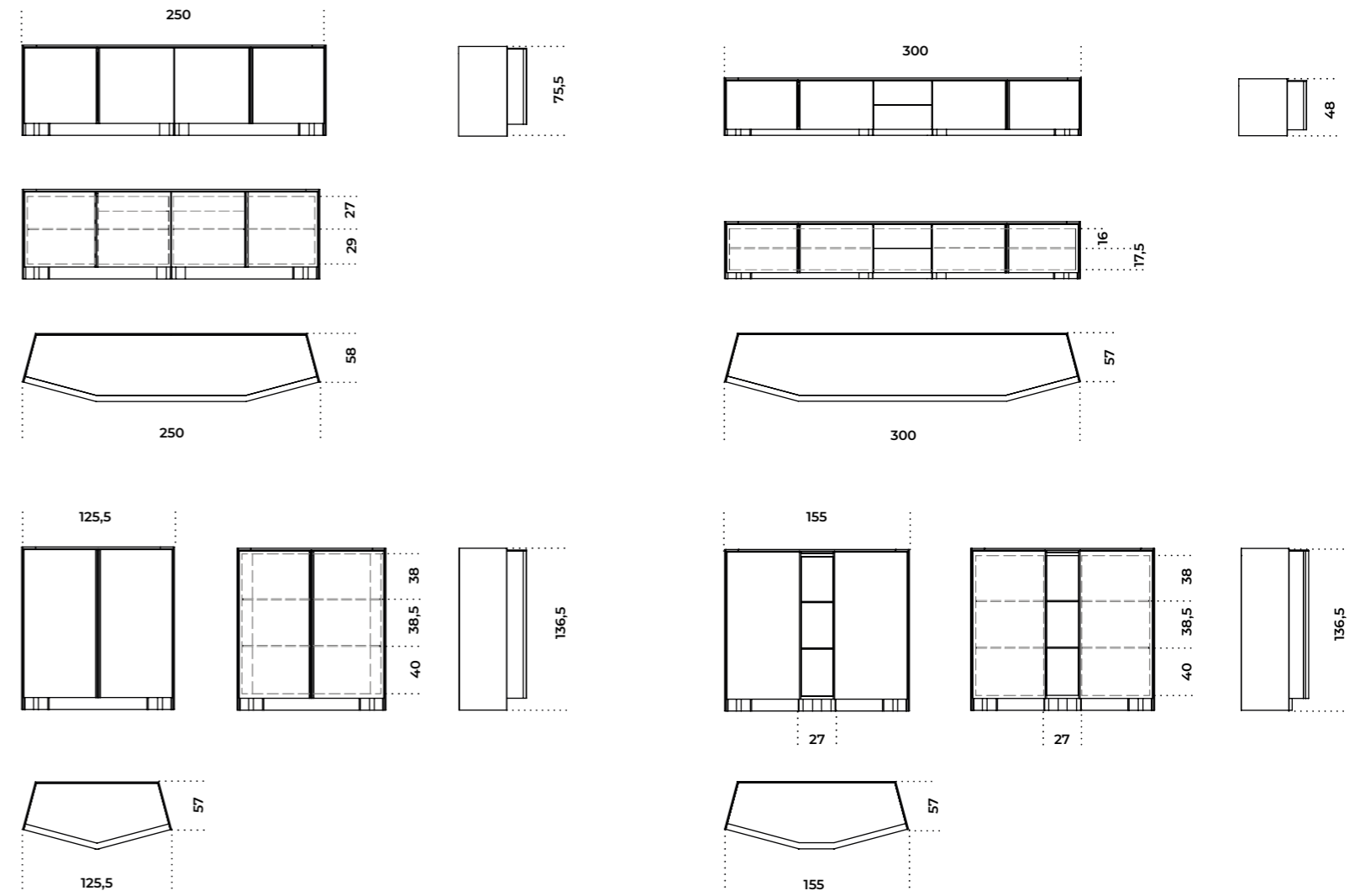

Diedro | Pietro Russo, 2017

Product information / p. 344

Versione freestanding / Freestanding version

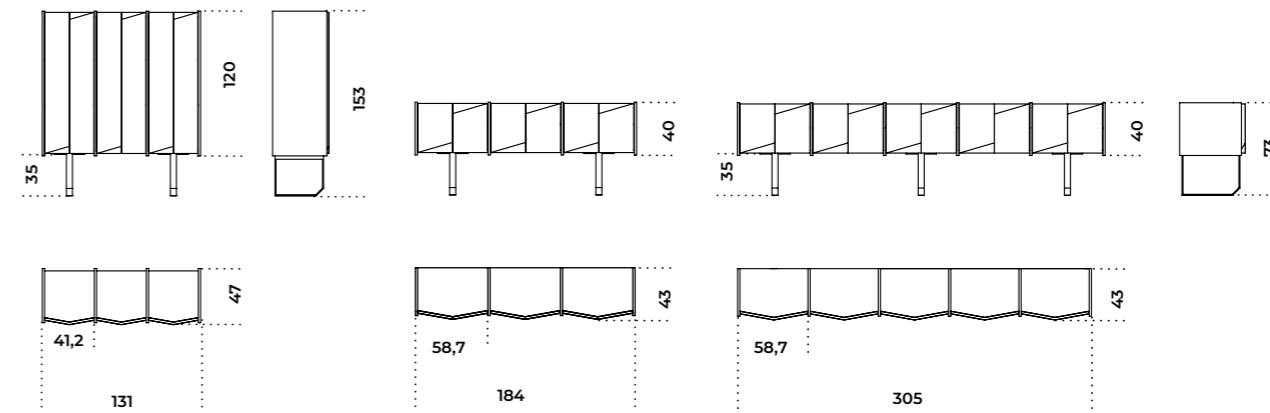

Versione pensile / Suspended version

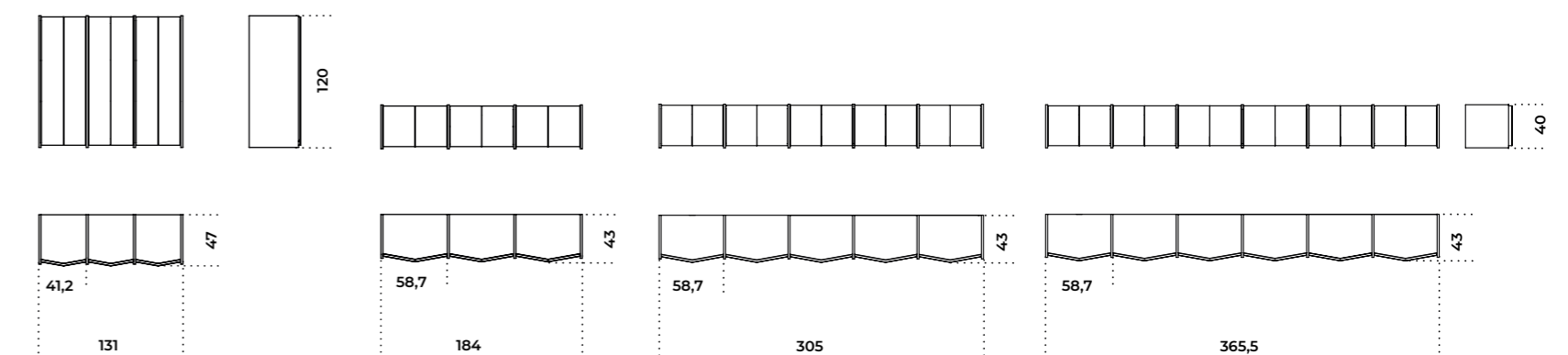

Gastone | Carlo Colombo, 2023

Product information / p. 346

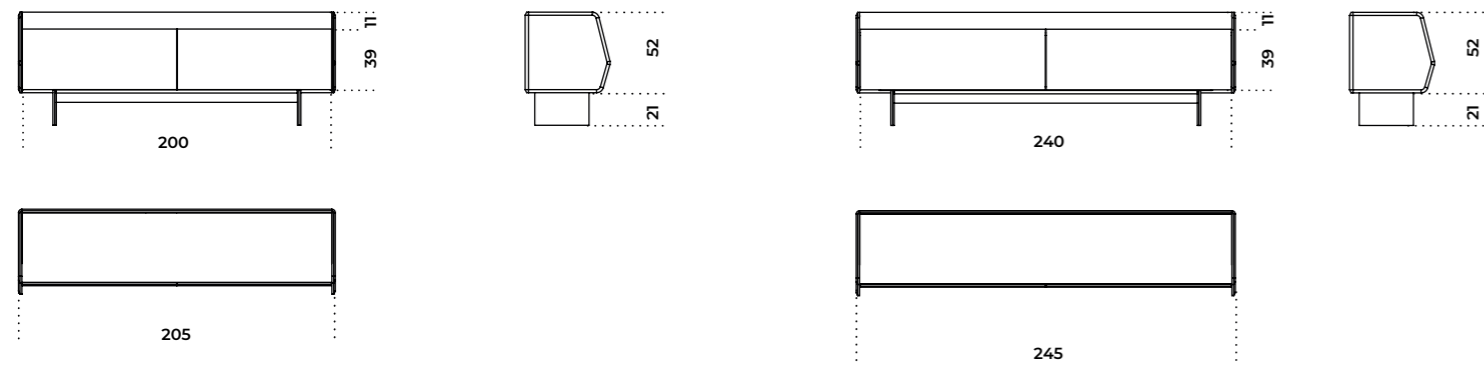

Versione AA (ante)
Version AA (doors)

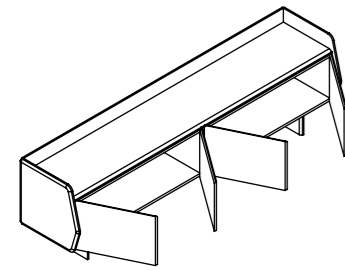

Cm
205 x 55 x 73,5h
245 x 55 x 73,5h

Inches
80¾" x 21¾" x 29"
96½" x 21¾" x 29"

Ripiano interno in cristallo extralight
Inside extralight glass shelf

Cm
100
120

Inches
39½"
47¼"

Versione CC (cassettone)
Version CC (large drawers)

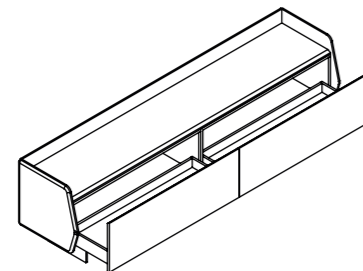

Cm
205 x 55 x 73,5h
245 x 55 x 73,5h

Inches
80¾" x 21¾" x 29"
96½" x 21¾" x 29"

Cassetto interno
Inside drawer

Cm
100
120

Inches
39½"
47¼"

Versione RR (ribalte)
Version RR (flap doors)

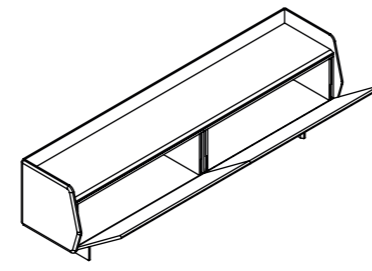

Cm
205 x 55 x 73,5h
245 x 55 x 73,5h

Inches
80¾" x 21¾" x 29"
96½" x 21¾" x 29"

Versione AC (ante/cassettone)
Version AC (doors/large drawer)

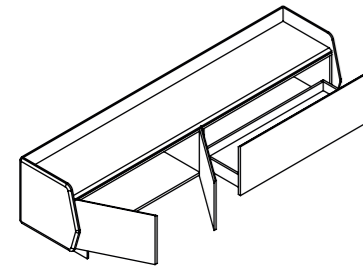

Cm
205 x 55 x 73,5h
245 x 55 x 73,5h

Inches
80¾" x 21¾" x 29"
96½" x 21¾" x 29"

Ripiano interno in cristallo extralight
Inside extralight glass shelf

Cassetto interno
Inside drawer

Cm
100
120

Inches
39½"
47¼"

Versione AR (ante/ribalta)
Version AR (doors/flap door)

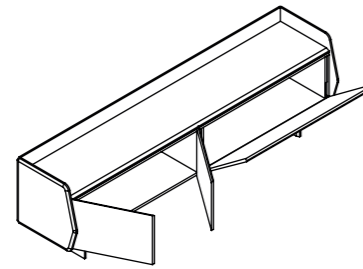

Cm
205 x 55 x 73,5h
245 x 55 x 73,5h

Inches
80¾" x 21¾" x 29"
96½" x 21¾" x 29"

Ripiano interno in cristallo extralight
Inside extralight glass shelf

Cm
100
120

Inches
39½"
47¼"

Versione RC (ribalta/cassettone)
Version RC (flap door/large drawer)

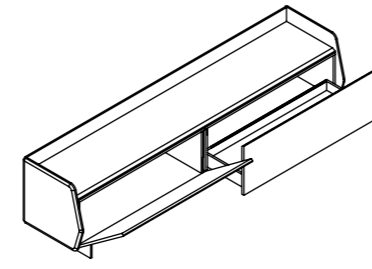

Cm
205 x 55 x 73,5h
245 x 55 x 73,5h

Inches
80¾" x 21¾" x 29"
96½" x 21¾" x 29"

Cassetto interno
Inside drawer

Cm
100
120

Inches
39½"
47¼"

Top in marmo (opzionale)
Marble top (optional)

Cm
200
240

Inches
78¾"
94½"

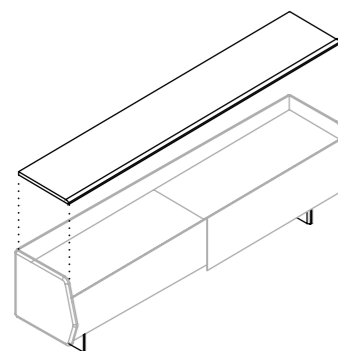

Mensola superiore sagomata in cristallo (opzionale)
Shaped upper glass shelf (optional)

Cm
200
240

Inches
78¾"
94½"

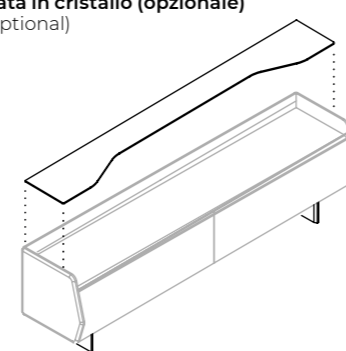

Gastone Low | Carlo Colombo, 2023

Product information / p. 348

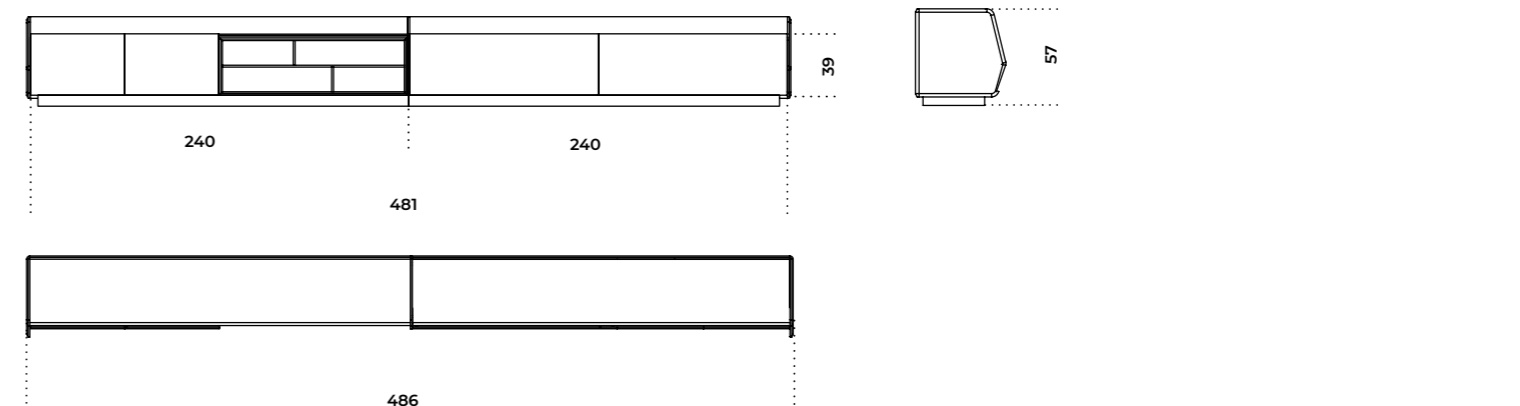
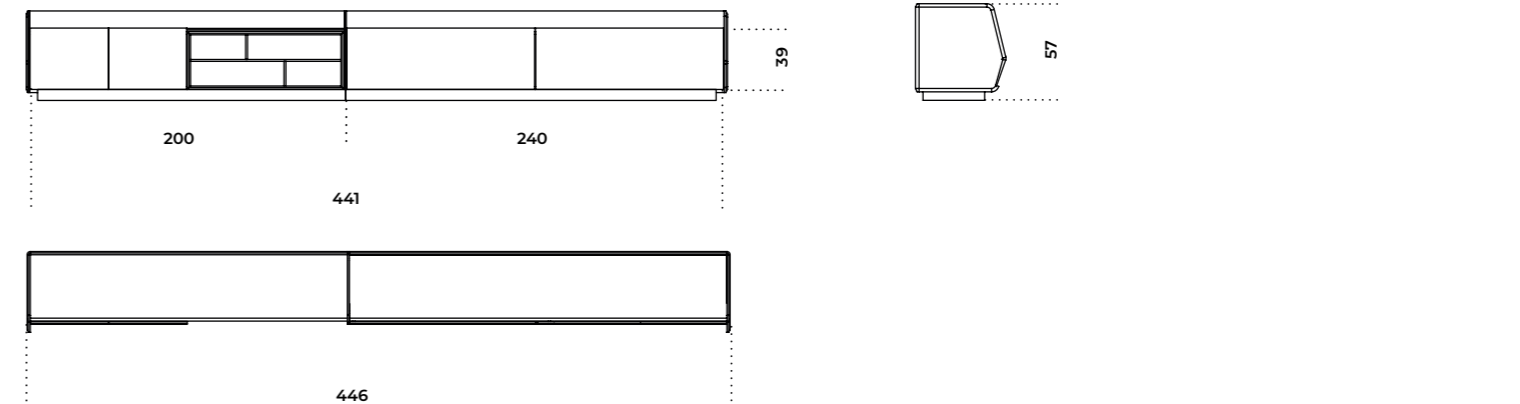
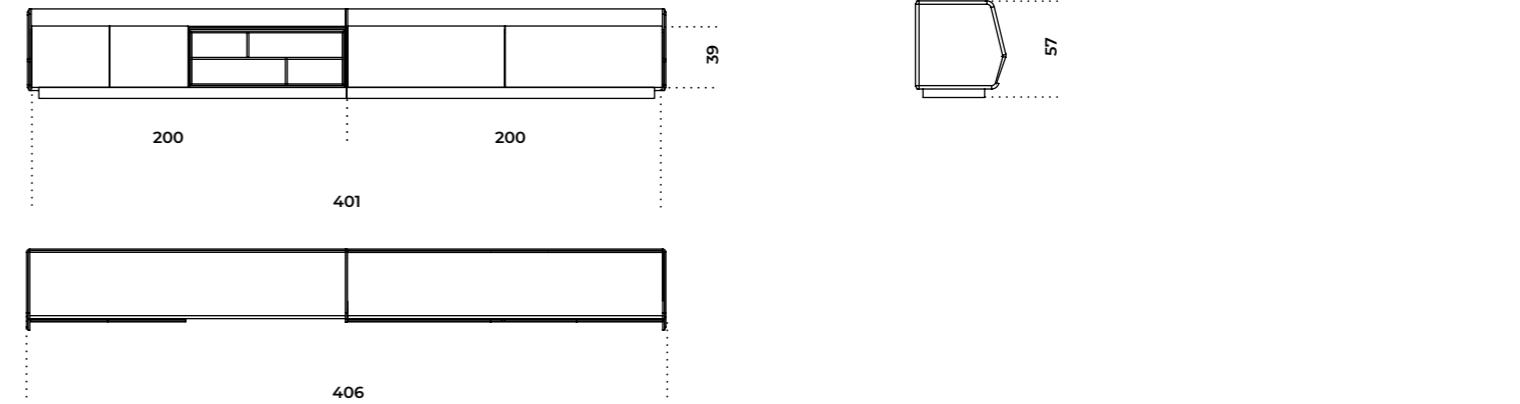
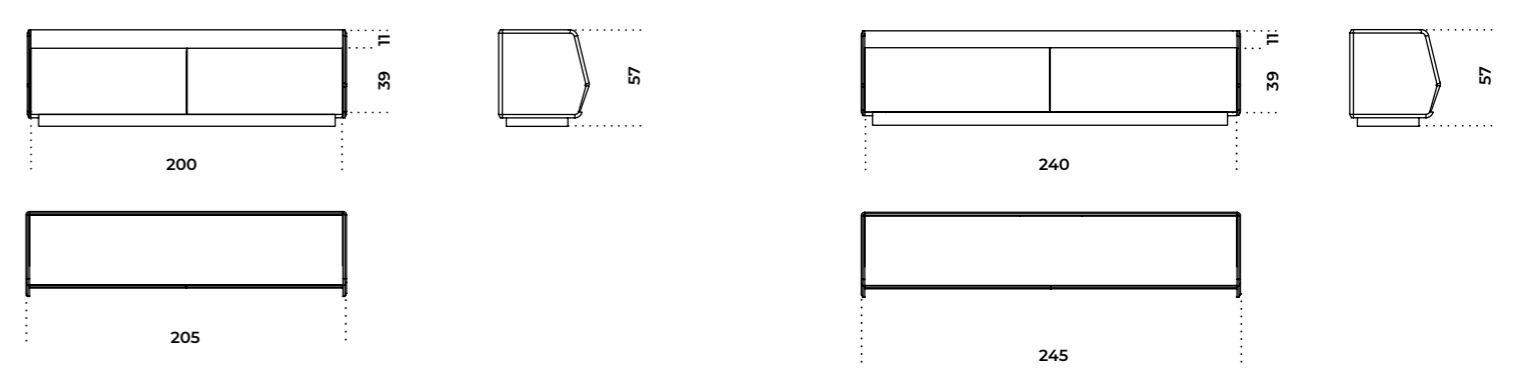

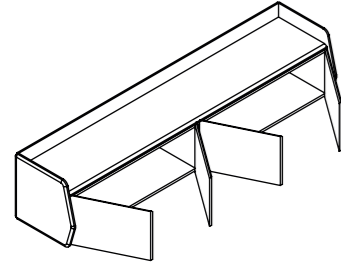
Versione AA (ante)
Version AA (doors)

Cm
205 x 55 x 57h
245 x 55 x 57h

Inches
80¾" x 21¾" x 22½"
96½" x 21¾" x 22½"

Ripiano interno in cristallo extralight
Inside extralight glass shelf

Cm
100
120

Inches
39½"
47¼"

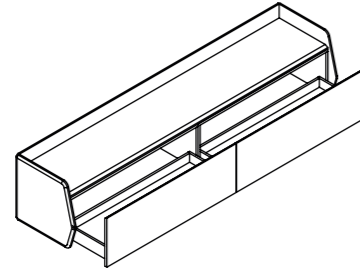
Versione CC (cassettoni)
Version CC (large drawers)

Cm
205 x 55 x 57h
245 x 55 x 57h

Inches
80¾" x 21¾" x 22½"
96½" x 21¾" x 22½"

Cassetto interno
Inside drawer

Cm
100
120

Inches
39½"
47¼"

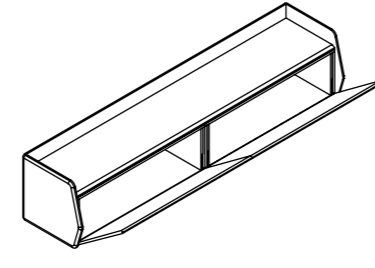
Versione RR (ribalte)
Version RR (flap doors)

Cm
205 x 55 x 57h
245 x 55 x 57h

Inches
80¾" x 21¾" x 22½"
96½" x 21¾" x 22½"

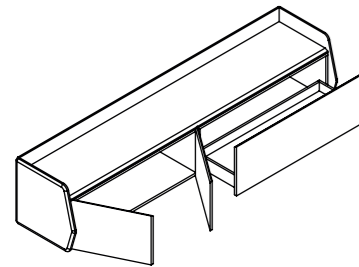
Versione AC (ante/cassettone)
Version AC (doors/large drawer)

Cm
205 x 55 x 57h
245 x 55 x 57h

Inches
80¾" x 21¾" x 22½"
96½" x 21¾" x 22½"

Ripiano interno in cristallo extralight
Inside extralight glass shelf**Cassetto interno**
Inside drawer

Cm
100
120

Inches
39½"
47¼"

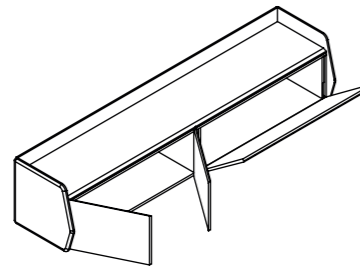
Versione AR (ante/ribalta)
Version AR (doors/flap door)

Cm
205 x 55 x 57h
245 x 55 x 57h

Inches
80¾" x 21¾" x 22½"
96½" x 21¾" x 22½"

Ripiano interno in cristallo extralight
Inside extralight glass shelf

Cm
100
120

Inches
39½"
47¼"

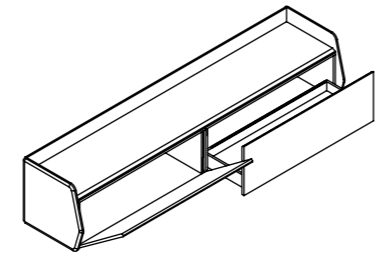
Versione RC (ribalta/cassettone)
Version RC (flap door/large drawer)

Cm
205 x 55 x 57h
245 x 55 x 57h

Inches
80¾" x 21¾" x 29"
96½" x 21¾" x 29"

Cassetto interno
Inside drawer

Cm
100
120

Inches
39½"
47¼"

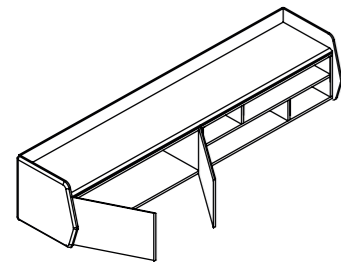
Versione AG (ante/giorno)
Version AG (doors/open)

Cm
205 x 55 x 57h
245 x 55 x 57h

Inches
80¾" x 21¾" x 22½"
96½" x 21¾" x 22½"

Ripiano interno in cristallo extralight
Inside extralight glass shelf

Cm
100
120

Inches
39½"
47¼"

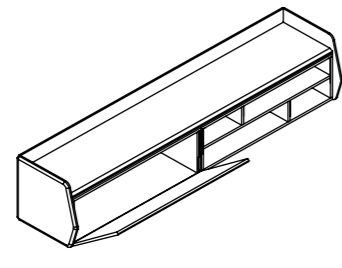
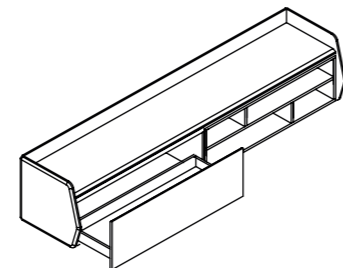
Versione RG (ribalta/giorno)
Version RG (flap door/open)**Versione CG (cassettone/giorno)**
Version CG (large drawer/open)

Cm
205 x 55 x 57h
245 x 55 x 57h

Inches
80¾" x 21¾" x 29"
96½" x 21¾" x 29"

Cassetto interno
Inside drawer

Cm
100
120

Inches
39½"
47¼"

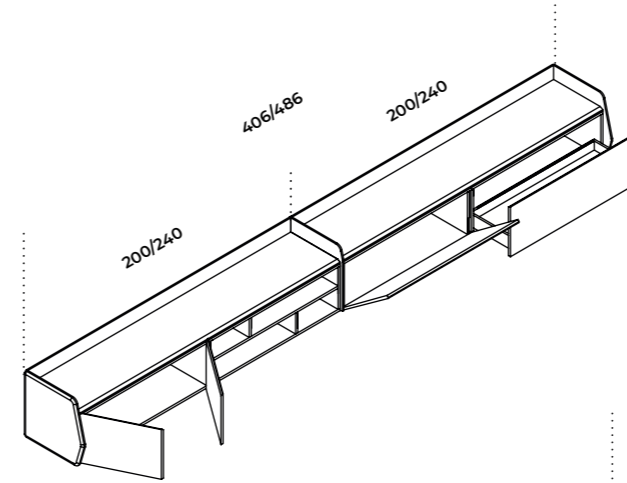
Versione AGRC (ante/giorno/ribalta/cassettone)
Version AGRC (doors/open/flap door/large drawer)

Cm
406 x 55 x 57
446 x 55 x 57
486 x 55 x 57

Inches
160" x 21¾" x 22½"
175¼" x 21¾" x 22½"
191½" x 21¾" x 22½"

Ripiano interno in cristallo extralight
Inside extralight glass shelf

Cm
100
120

Inches
39½"
47¼"

Cassetto interno
Inside drawer

Cm
100
120

Inches
39½"
47¼"

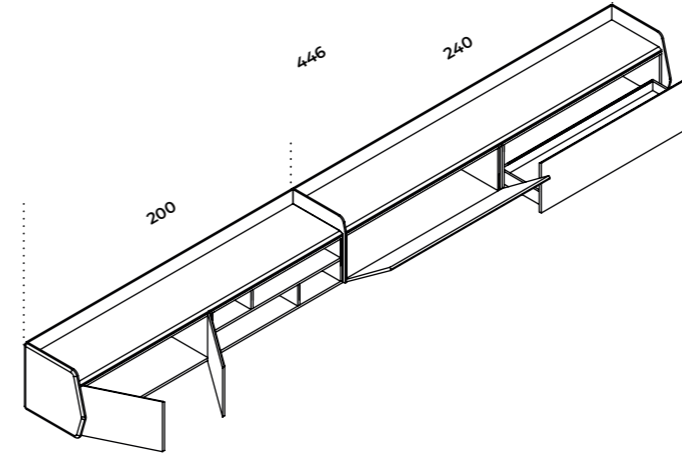
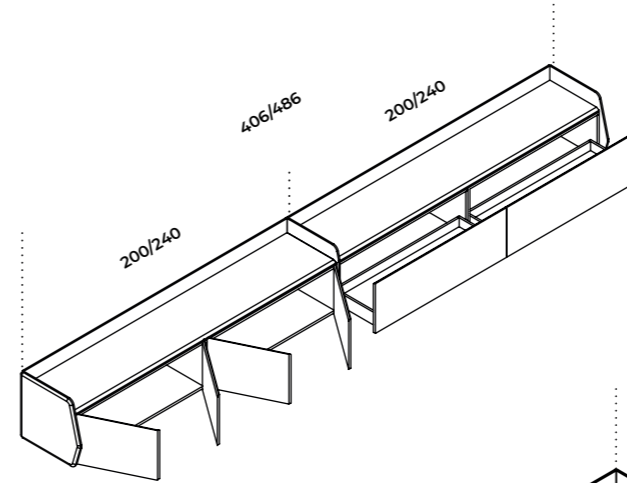
**Versione AACC (ante/cassettoni)**
Version AACC (doors/large drawers)

Cm
406 x 55 x 57
446 x 55 x 57
486 x 55 x 57

Inches
160" x 21¾" x 22½"
175¼" x 21¾" x 22½"
191½" x 21¾" x 22½"

Ripiano interno in cristallo extralight
Inside extralight glass shelf

Cm
100
120

Inches
39½"
47¼"

Cassetto interno
Inside drawer

Cm
100
120

Inches
39½"
47¼"

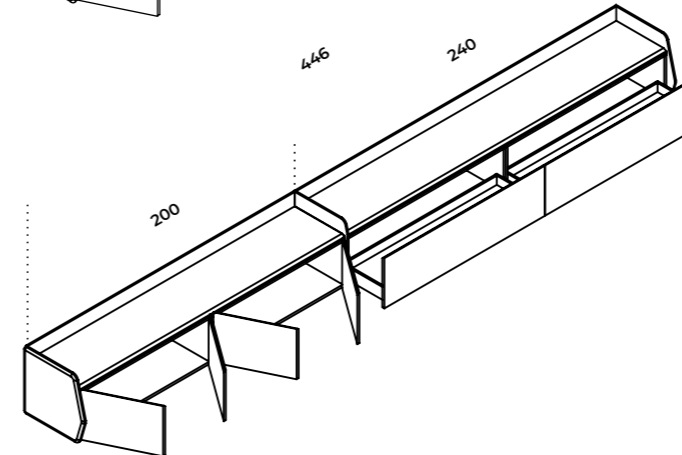

Versione RGCC (ribalta/giorno/cassettoni)
Version RGCC (flap door/open/large drawers)

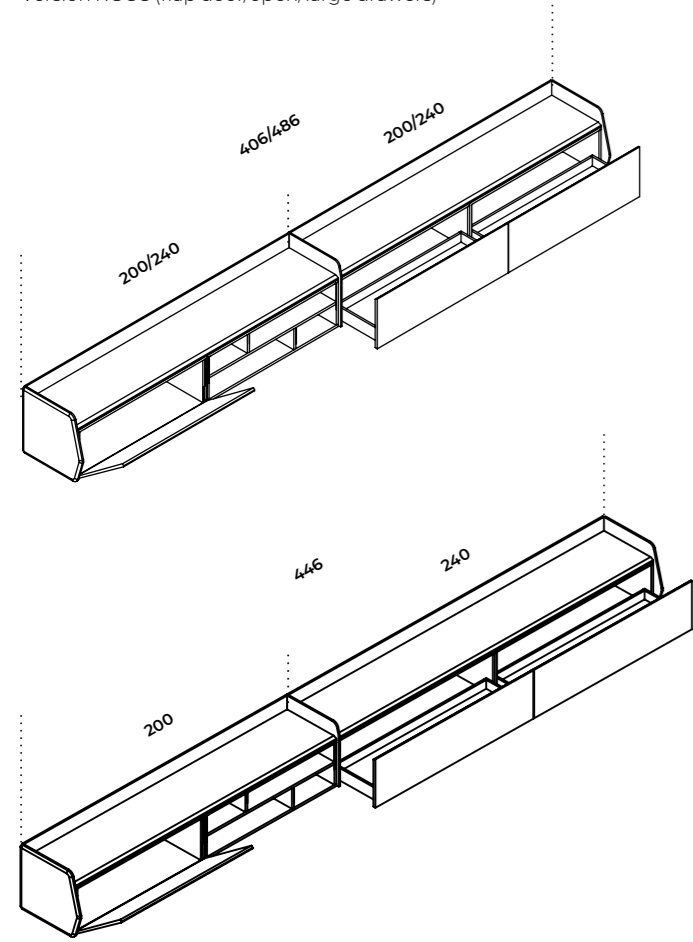

Cm
406 x 55 x 57
446 x 55 x 57
486 x 55 x 57

Inches
160" x 21¾" x 22½"
175¼" x 21¾" x 22½"
191½" x 21¾" x 22½"

Ripiano interno in cristallo extralight
Inside extralight glass shelf

Cm
100
120

Inches
39½"
47¼"

Cassetto interno
Inside drawer

Cm
100
120

Inches
39½"
47¼"

Versione CGAA (cassettone/giorno/ante)
Version CGAA (large drawer/open/doors)

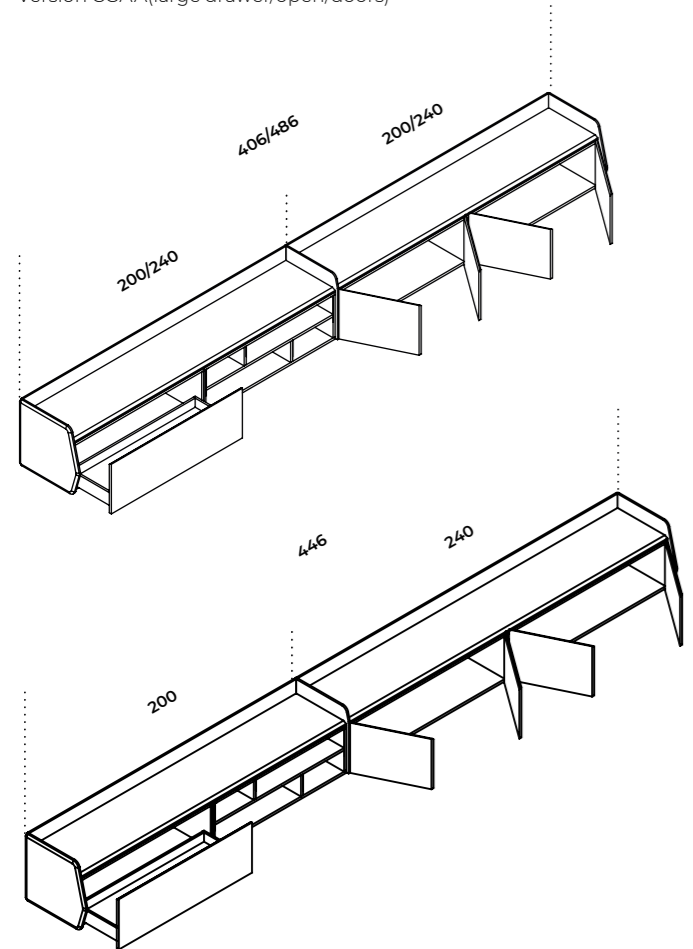

Cm
406 x 55 x 57
446 x 55 x 57
486 x 55 x 57

Inches
160" x 21¾" x 22½"
175¼" x 21¾" x 22½"
191½" x 21¾" x 22½"

Ripiano interno in cristallo extralight
Inside extralight glass shelf

Cm
100
120

Inches
39½"
47¼"

Cassetto interno
Inside drawer

Cm
100
120

Inches
39½"
47¼"

Top in marmo (opzionale)
Marble top (optional)

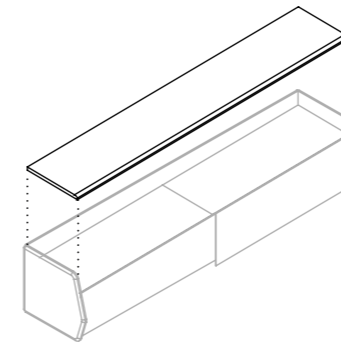

Cm
200
240

Inches
78¾"
94½"

Mensola superiore sagomata in cristallo (opzionale)
Shaped upper glass shelf (optional)

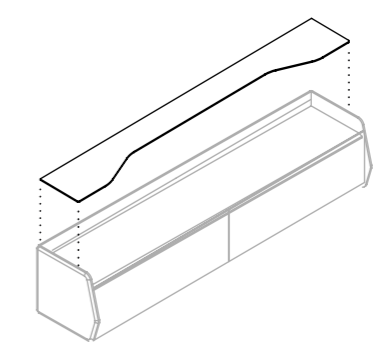

Cm
200
240

Inches
78¾"
94½"

Hide&Seek | Pietro Russo, 2021

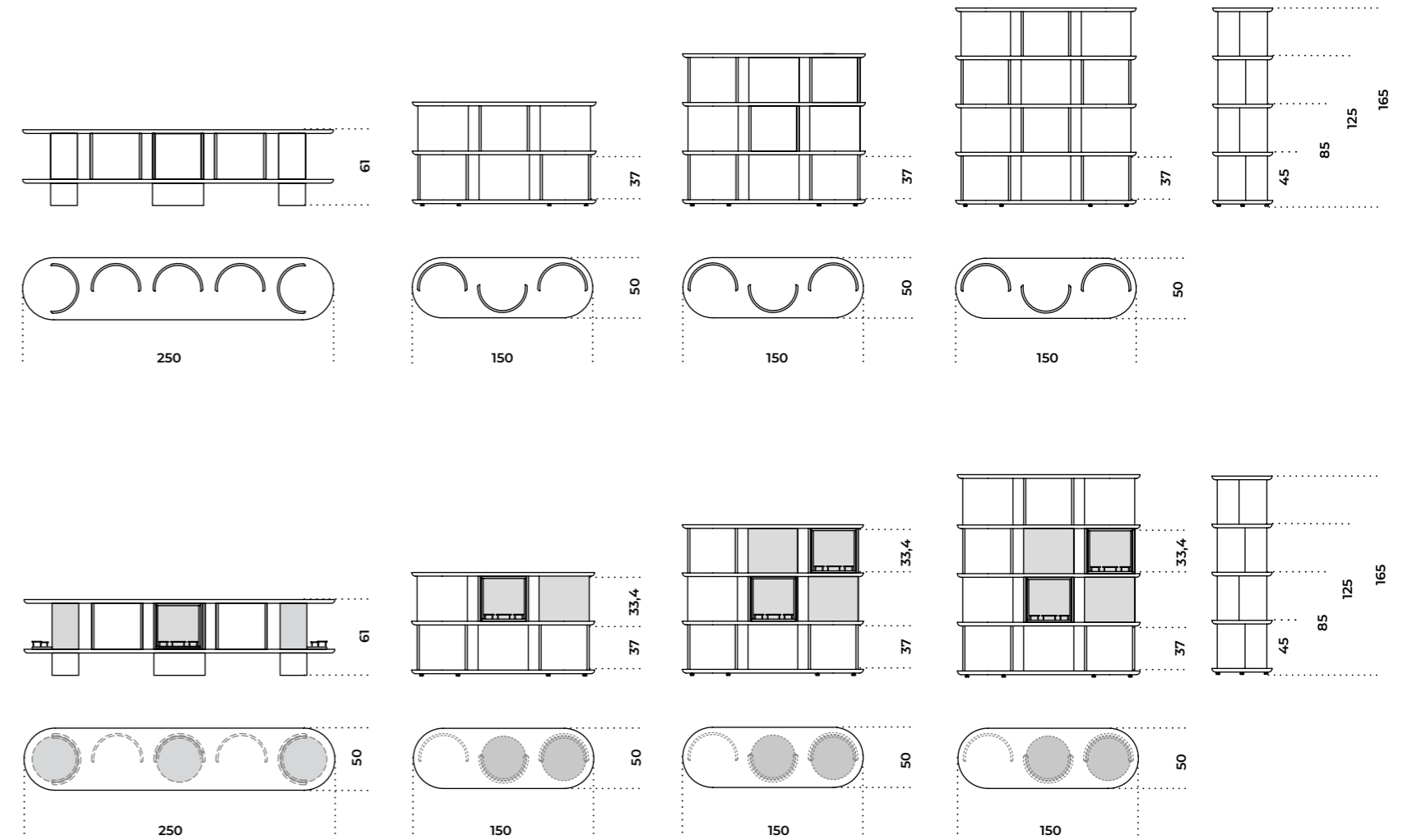

■ **Vassoi girevoli / Swivel trays**

Kumi Credenza | Carlo Colombo, 2020

Product information / p. 354

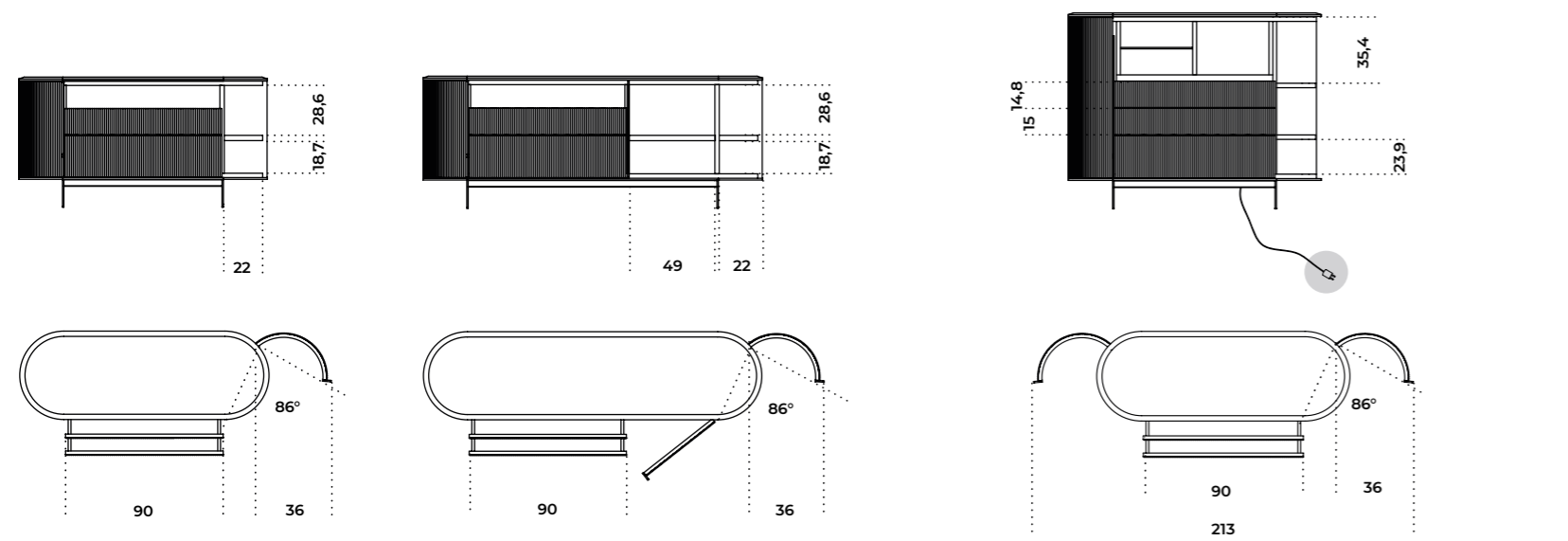
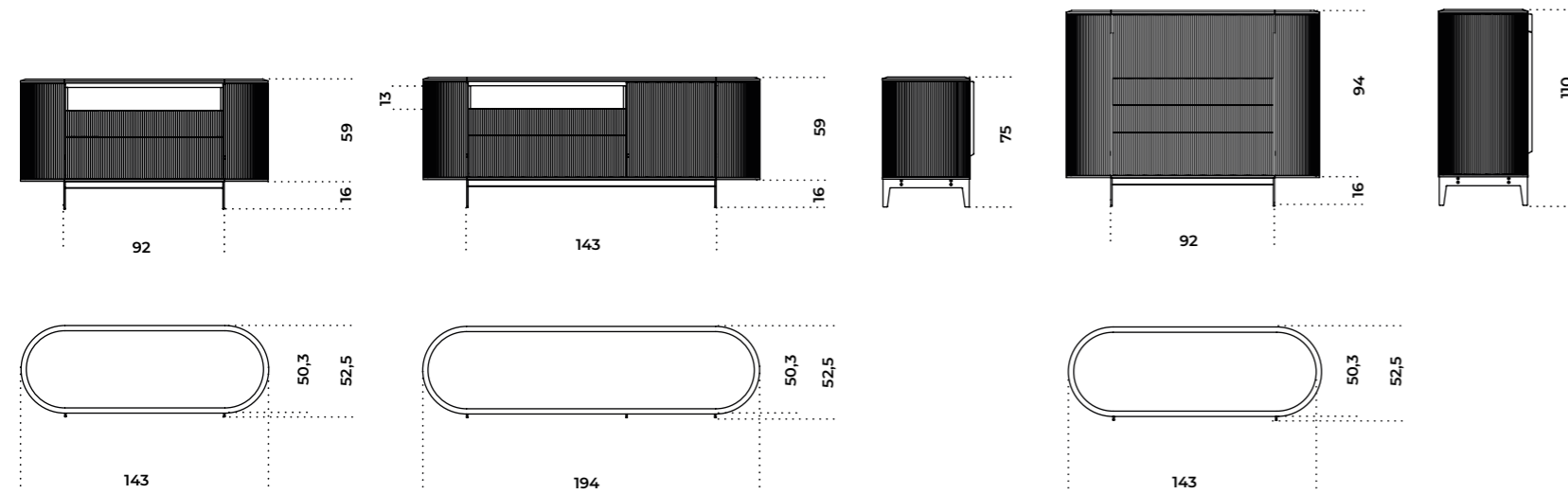

Pandora Cashmere | Pinuccio Borgonovo, 2020

Product information / p. 358

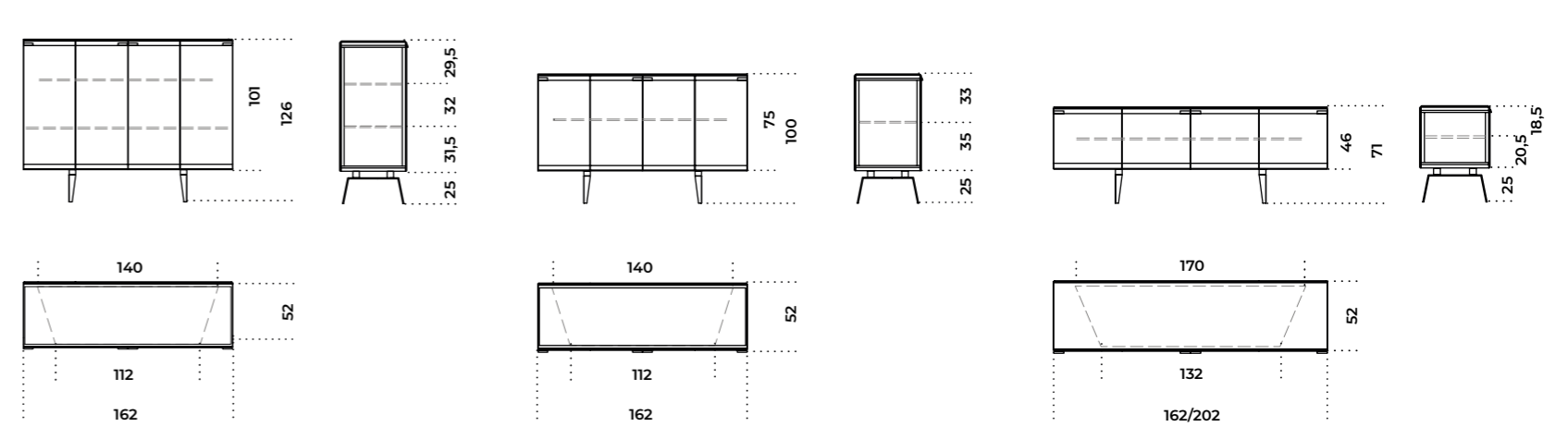

Pandora Craquelé | Pinuccio Borgonovo, 2016

Product information / p. 360

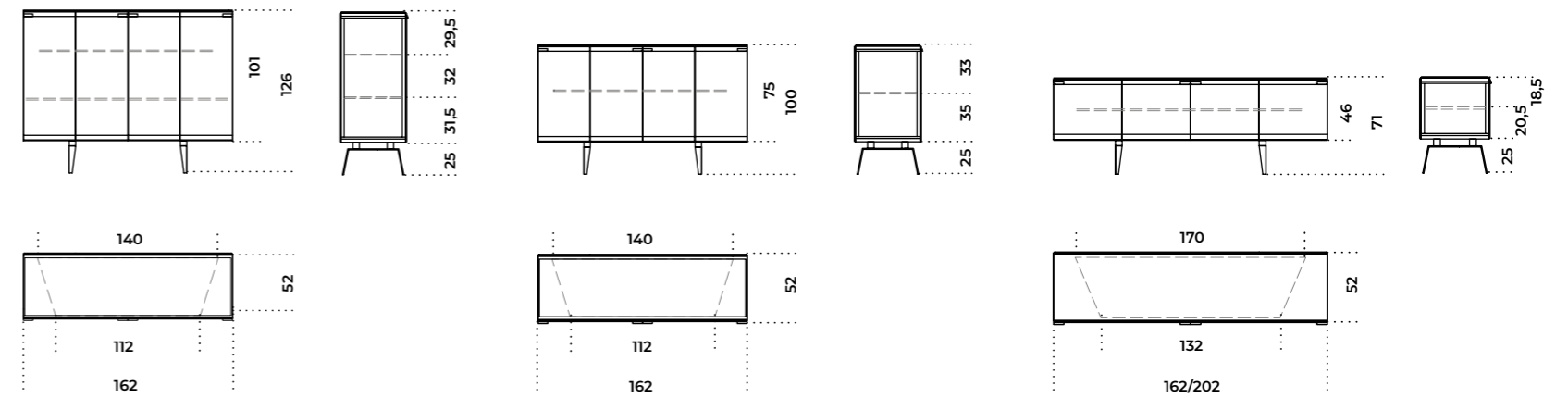

Pandora | Pinuccio Borgonovo, 2014

Product information / p. 356

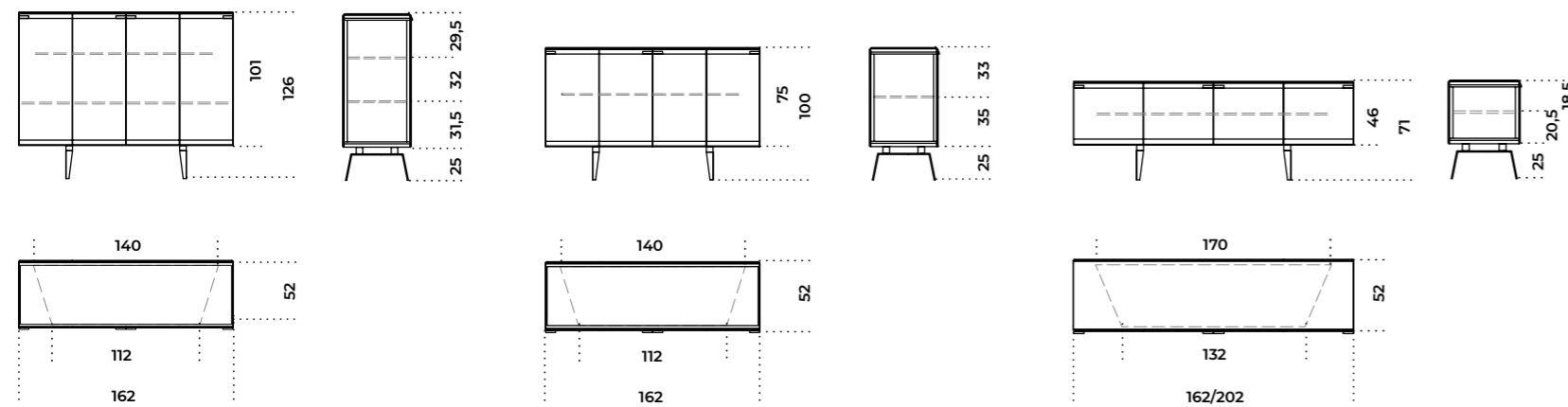

Pandora Light | Pinuccio Borgonovo, 2016

Product information / p. 362

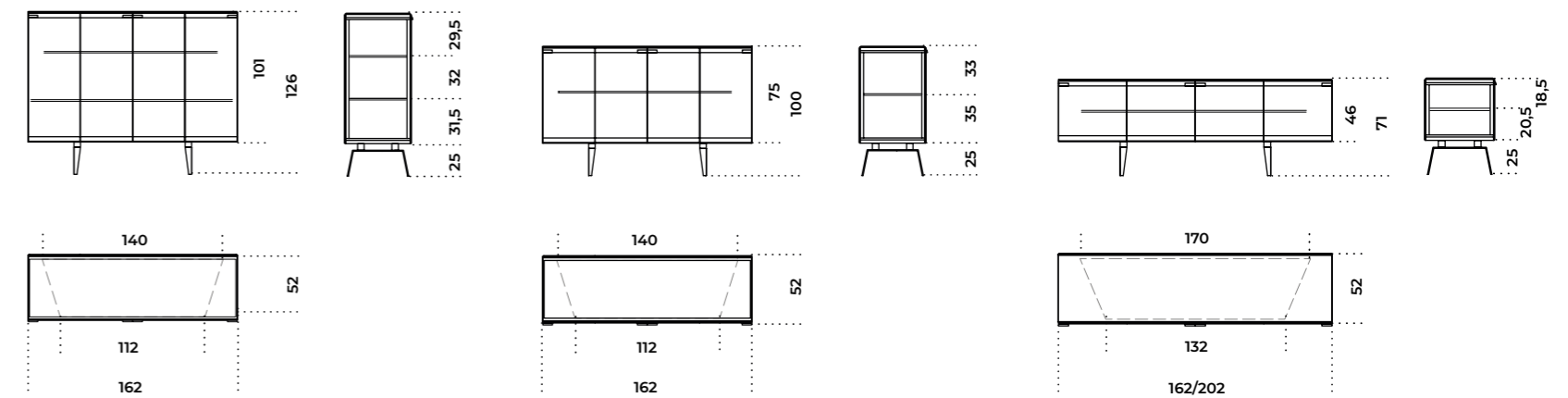

Soda | Draga & Aurel, 2022

Product information / p. 364

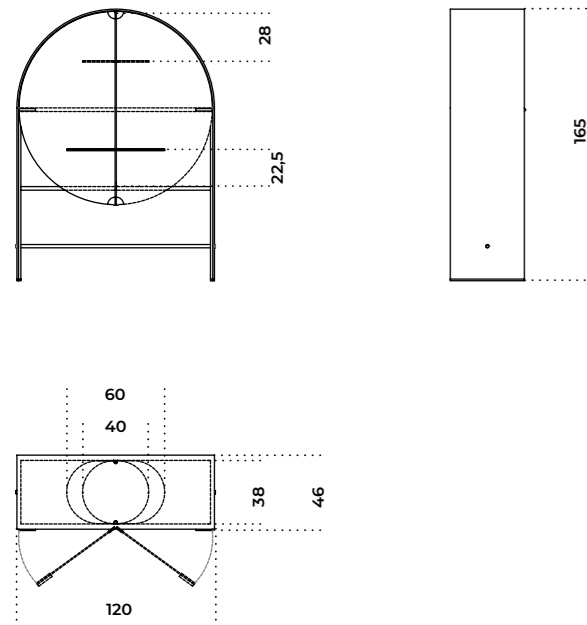

Tama Crédence | Carlo Colombo, 2016

Product information / p. 370

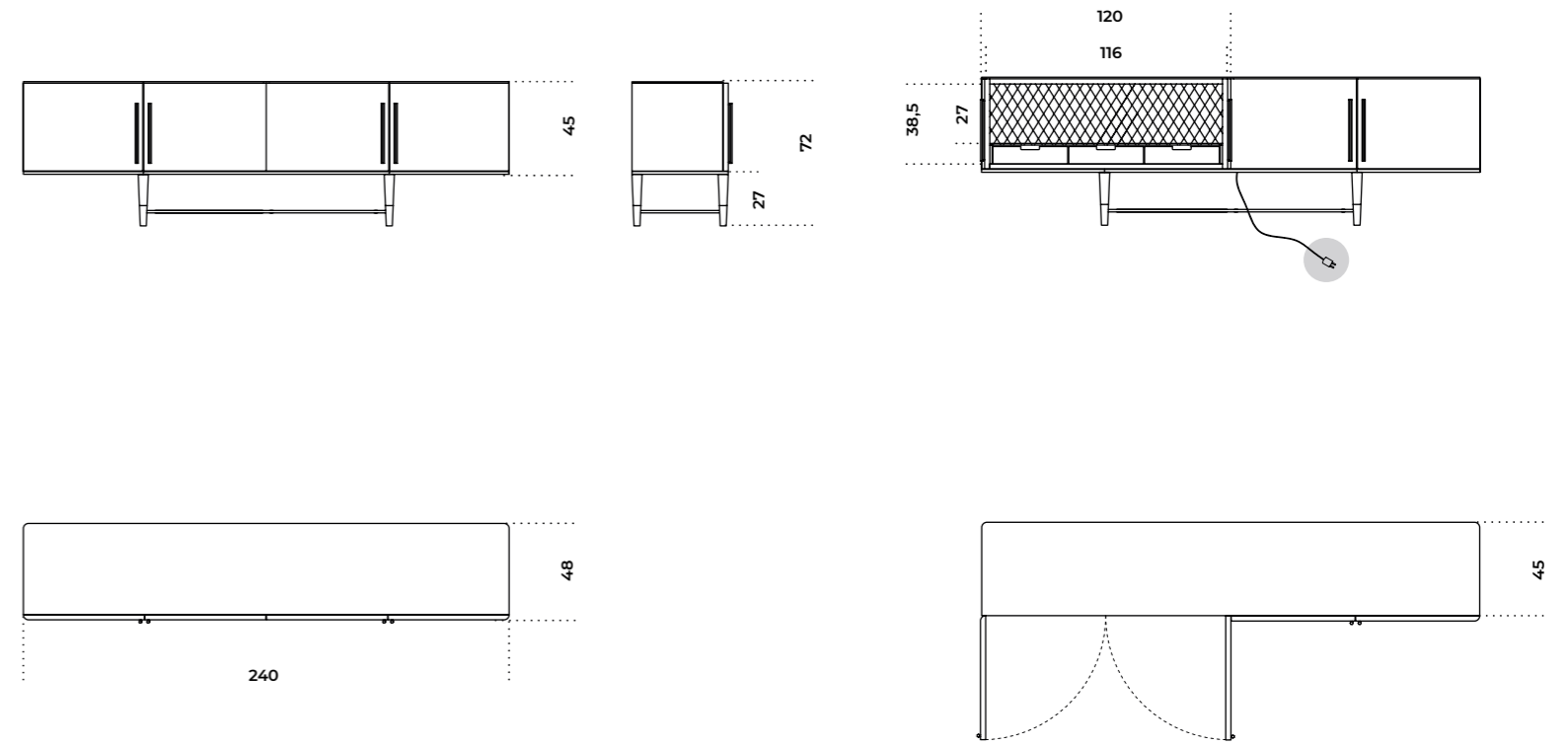

Tipologie di presa:
Types of socket:

220V Presa Europea
European socket

220V Presa UK
UK socket

110V Presa UL USA
USA UL socket

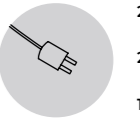

Tama | Carlo Colombo, 2015

Product information / p. 368

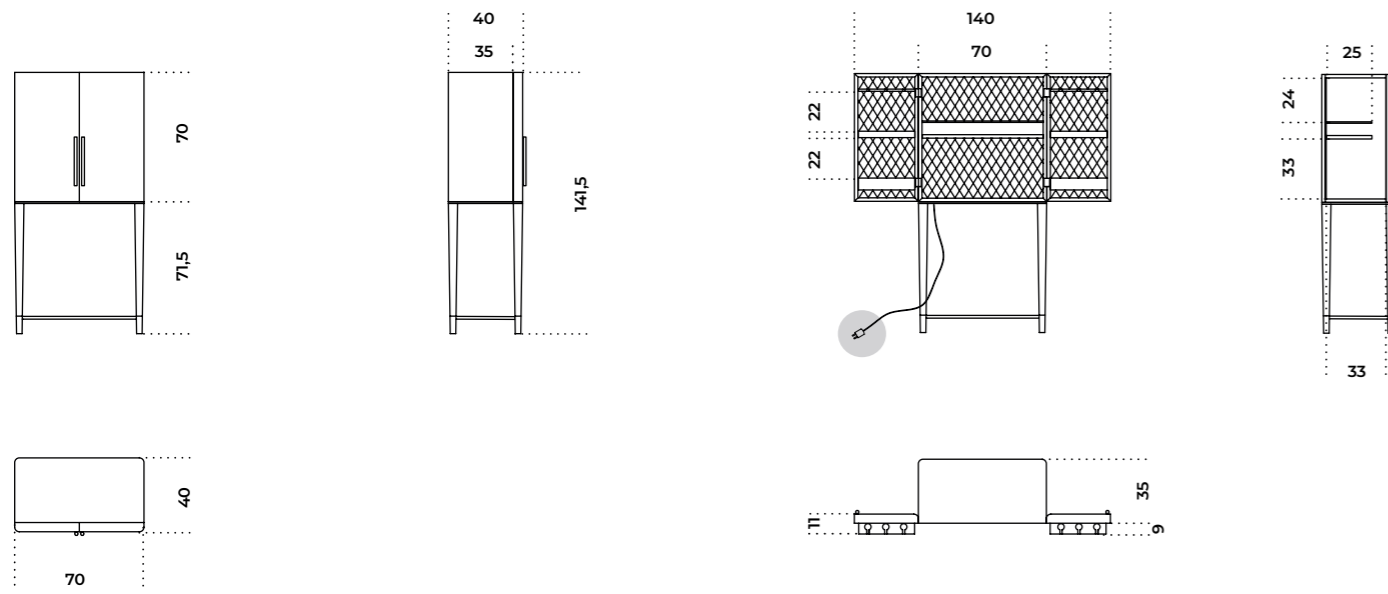

Tipologie di presa:
Types of socket:

220V Presa Europea
European socket

220V Presa UK
UK socket

110V Presa UL USA
USA UL socket

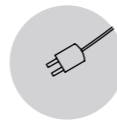

Tama Vitrine | Carlo Colombo, 2020

Product information / p. 372

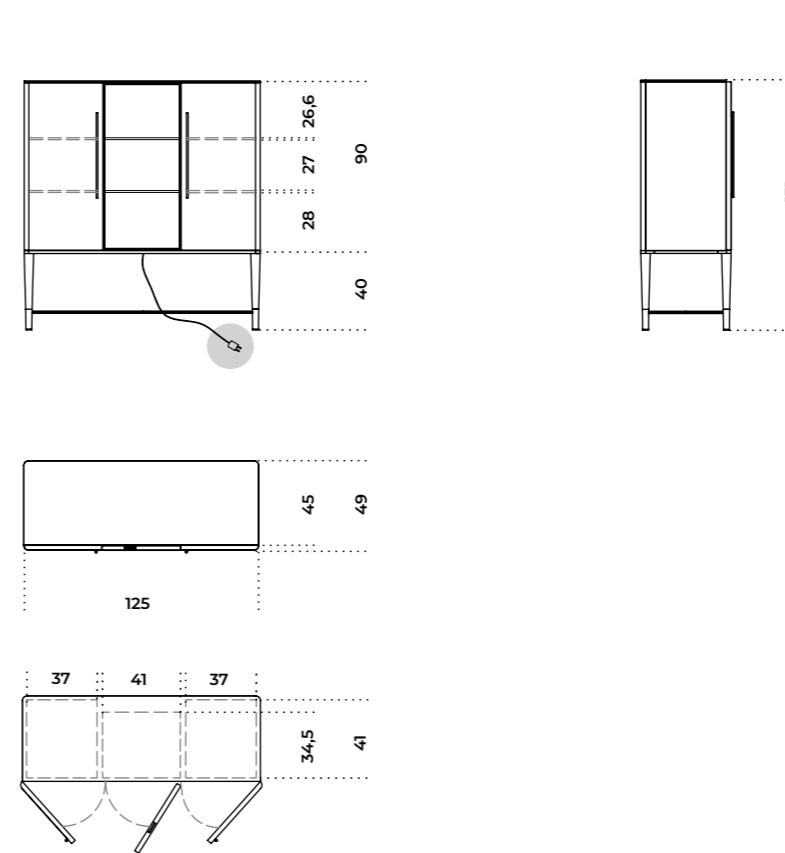

Tipologie di presa:
Types of socket:

220V Presa Europea
European socket

220V Presa UK
UK socket

110V Presa UL USA
USA UL socket

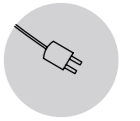

09 Librerie e boiserie / Shelving systems and boiserie

- [390](#) **Brera**
- [392](#) **Brera 23**
- [394](#) **Drizzle**
- [396](#) **Isola**
- [400](#) **Navigli**
- [402](#) **Pleiadi**
- [404](#) **Prism Divider**
- [408](#) **Roundcut**
- [410](#) **Syil**
- [412](#) **Tortona**

- [414](#) **Informazioni tecniche /**
Technical informations



▲ BRERA

Montanti verticali in ottone nichelato satinato / Ripiani in frassino tinto nero poro aperto / Contenitore ad anta con frontale in cristallo Craquelé
Satin nickel-plated brass vertical supports / Black open pore stained ash shelves / Door units with glass fronts in Craquelé

Brera

Massimo Castagna / 2016

Libreria con montanti verticali in ottone nichelato satinato. Ripiani in frassino tinto nero poro aperto. Contenitori ad anta o ribalta, con frontali in cristallo temperato decorato a mano nella finitura Craquelé. Disponibile anche con frontali in cristallo temperato retroverniciato nei colori del campionario, nella versione brillante o satinata. Su richiesta con pannello in frassino tinto nero poro aperto per posizionamento tv. Il pannello è retro illuminato a LED (30 Watt) con accensione a telecomando. Disponibile versione con montanti verticali laccati neri e parti in legno in Noce "Colore" Frisé. Contenitori ad anta o ribalta, con frontali in cristallo 6mm temperato verniciato nella finitura metallo liquido color Lava. Disponibile fino ad esaurimento scorte.

- ! Disponibile fino ad esaurimento scorte.
- ! Portata massima della mensola: 10 kg con muro pieno, uniformemente distribuiti.

NOTE TECNICHE SUI MATERIALI

CRISTALLO | Le finiture esclusive, risultato della lavorazione manuale realizzata sul cristallo, possono presentare striature e differenze cromatiche. Queste caratteristiche non devono essere considerate difetti ma elementi distintivi del processo artigianale che esaltano la bellezza e la peculiarità del pezzo unico.

METALLO LIQUIDO | La componente metallica della vernice fa sì che durante l'applicazione il naturale procedimento di ossidazione crei disomogeneità di sfumature che conferiscono carattere ed unicità alla superficie. Il procedimento naturale viene accentuato attraverso l'utilizzo di acidi e la spazzolatura permette di ottenere i due diversi colori.

Wall shelving system with satin nickel-plated brass vertical supports. Black open pore stained ash shelves. Door or flap door units with hand decorated tempered glass fronts Craquelé finish. Also available with painted tempered glass fronts as per samples in the bright or satin version. With black open pore stained ash TV Panel, on request. LED TV Panel (30 Watt) to be switched on with remote control. Available version with black lacquered vertical supports and "Colore" Frisé Walnut wooden parts. Door or flap door units with 6mm tempered liquid metal lacquered glass fronts in the colour Lava. Available while stocks last.

- ! Available while stocks last.
- ! Max capacity of the shelf: 10 kg on solid wall, evenly distributed

TECHNICAL INFORMATION ON THE MATERIALS

GLASS | Exclusive finishes, resulting from the craftsmanship on the glass, may show streaks and chromatic differences. These characteristics should not be considered imperfections but distinctive evidence of the hand-made process that enhance the beauty and peculiarity of the unique piece.

LIQUID METAL | The metallic component of the paint during the natural oxidation process creates uneven shades, that give uniqueness to the surface. The natural oxidation process is then enhanced by the use of acids and manual brushing to achieve the two different colours.

	Cm	Inches
60M164	60 x 25 x 164	23¾" x 10" x 64¾"
80M164	80 x 25 x 164	31½" x 10" x 64¾"
120M164	120 x 25 x 164	47¼" x 10" x 64¾"
60M240	60 x 25 x 240	23¾" x 10" x 94½"
80M240	80 x 25 x 240	31½" x 10" x 94½"
120M240	120 x 25 x 240	47¼" x 10" x 94½"

160M164	160 x 25 x 164	63" x 10" x 64¾"
160M240	160 x 25 x 240	63" x 10" x 94½"

60A164	60 x 25 x 164	23¾" x 10" x 64¾"
60A240	60 x 25 x 240	23¾" x 10" x 94½"

	Cm	Inches
80R164	80 x 25 x 164	31½" x 10" x 64¾"
120R164	120 x 25 x 164	47¼" x 10" x 64¾"
80R240	80 x 25 x 240	31½" x 10" x 94½"
120R240	120 x 25 x 240	47¼" x 10" x 94½"

160R164	160 x 25 x 164	63" x 10" x 64¾"
160R240	160 x 25 x 240	63" x 10" x 94½"

160TV164	160 x 35 x 164	63" x 14" x 64¾"
160TV240	160 x 35 x 240	63" x 14" x 94½"

For technical drawing / p.416

Pricelist 2023 / p. 264
Homescapes, sense of materials / pp. 32, 88, 96
Homescapes, gentle attitude / pp. 38, 39

MONTANTI/ VERTICAL SUPPORTS



Ottone nichelato satinato
Satin nickel-plated brass

MONTANTI/ VERTICAL SUPPORTS

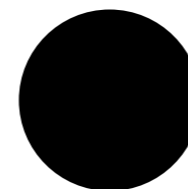

Laccato nero
Black lacquered

RIPIANI E CONTENITORI/ SHELVES AND UNITS

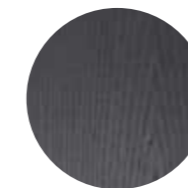

Frassino tinto
nero poro aperto
Black open pore stained ash

RIPIANI E CONTENITORI/ SHELVES AND UNITS



Legno Noce "Colore" Frisé
"Colore" Frisé Walnut wood

ANTA O RIBALTA/ DOOR OR FLAP DOOR



Cristallo Craquelé
Craquelé glass

ANTA O RIBALTA/ DOOR OR FLAP DOOR

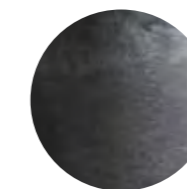

Cristallo verniciato
metallo liquido Lava
Liquid metal lacquered
Lava glass

PANNELLO TV/ TV PANEL

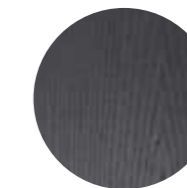

Frassino tinto
nero poro aperto
Black open pore stained ash

PANNELLO TV/ TV PANEL

LED
30WATT

Sample box

Cristallo brillante/satinato
nei colori del campionario
Glass bright/satin version
as per sample



• BRERA23

Montanti verticali in metallo laccato nero rivestiti in frassino laccato nero / Ripiani in legno Noce "Colore" Frisé / Contenitore ad anta con frontale in cristallo Cristallo verniciato metallo liquido Lava
Black lacquered metal covered by black lacquered solid ash vertical supports / "Colore" Frisé Walnut wood shelves / Door units with Liquid metal lacquered Lava glass front

Brera 23

Massimo Castagna / 2016

Libreria con montanti verticali in metallo laccato nero rivestiti in massello di frassino laccato nero. Ripiani in frassino tinto nero poro aperto oppure Noce "Colore" Frisé. Contenitori ad anta o ribalta, con frontali in cristallo 6mm temperato decorato a mano nella finitura Craquelé o verniciato nella finitura metallo liquido color Lava. Disponibile anche con frontali in cristallo temperato retroverniciato nei colori del campionario, nella versione brillante o satinata.

! Portata massima della mensola: 10 kg con muro pieno, uniformemente distribuiti

NOTE TECNICHE SUI MATERIALI

CRISTALLO | Le finiture esclusive, risultato della lavorazione manuale realizzata sul cristallo, possono presentare striature e differenze cromatiche. Queste caratteristiche non devono essere considerate difetti ma elementi distintivi del processo artigianale che esaltano la bellezza e la peculiarità del pezzo unico.

METALLO LIQUIDO | La componente metallica della vernice fa sì che durante l'applicazione il naturale procedimento di ossidazione crei disomogeneità di sfumature che conferiscono carattere ed unicità alla superficie. Il procedimento naturale viene accentuato attraverso l'utilizzo di acidi e la spazzolatura permette di ottenere i due diversi colori.

Wall shelving system with black lacquered metal vertical supports covered by black lacquered solid ash. Black open pore stained ash or "Colore" Frisé Walnut shelves. Door or flap door units with 6mm hand decorated tempered glass fronts in Craquelé finish or with 6mm tempered liquid metal lacquered glass fronts in the colour Lava. Also available with 6mm painted tempered glass fronts as per samples in the bright or satin version.

! Max capacity of the shelf: 10 kg on solid wall, evenly distributed

TECHNICAL INFORMATION ON THE MATERIALS

GLASS | Exclusive finishes, resulting from the craftsmanship on the glass, may show streaks and chromatic differences. These characteristics should not be considered imperfections but distinctive evidence of the hand-made process that enhance the beauty and peculiarity of the unique piece.

LIQUID METAL | The metallic component of the paint during the natural oxidation process creates uneven shades, that give uniqueness to the surface. The natural oxidation process is then enhanced by the use of acids and manual brushing to achieve the two different colours.

	Cm	Inches
N 60M164	60 x 25 x 164	23¾" x 10" x 64¾"
N 80M164	80 x 25 x 164	31½" x 10" x 64¾"
N 120M164	120 x 25 x 164	47¼" x 10" x 64¾"
N 60M240	60 x 25 x 240	23¾" x 10" x 94½"
N 80M240	80 x 25 x 240	31½" x 10" x 94½"
N 120M240	120 x 25 x 240	47¼" x 10" x 94½"
N 160M164	160 x 25 x 164	63" x 10" x 64¾"
N 240M164	240 x 25 x 164	94½" x 10" x 64¾"
N 160M240	160 x 25 x 240	63" x 10" x 94½"
N 240M240	240 x 25 x 240	94½" x 10" x 94½"
N 60A164	60 x 35 x 164	23¾" x 14" x 64¾"
N 60A240 N	60 x 35 x 240	23¾" x 14" x 94½"
N 80R164	80 x 35 x 164	31½" x 14" x 64¾"
N 120R164	120 x 35 x 164	47¼" x 14" x 64¾"
N 80R240	80 x 35 x 240	31½" x 14" x 94½"
N 120R240	120 x 35 x 240	47¼" x 14" x 94½"
N 160R240	160 x 35 x 164	63" x 14" x 64¾"
N 240R164	240 x 35 x 164	94½" x 14" x 64¾"
N 160R240	160 x 35 x 240	63" x 14" x 94½"
N 240R240	240 x 35 x 240	94½" x 14" x 94½"

For technical drawing / p. 417

Pricelist 2023 / p. 266
Homescapes, sense of materials / pp. 32, 88, 96
Homescapes, gentle attitude / pp. 38, 39

MONTANTI/ VERTICAL SUPPORTS

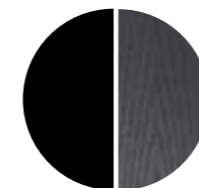

Metallo laccato nero rivestiti in massello di frassino laccato nero
Black lacquered metal covered by black lacquered solid ash

RIPIANI E CONTENITORI/ SHELVES AND UNITS

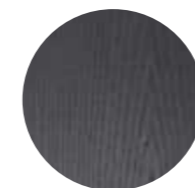

Frassino tinto nero poro aperto
Black open pore stained ash



Legno Noce "Colore" Frisé
"Colore" Frisé Walnut wood

ANTA O RIBALTA/ DOOR OR FLAP DOOR



Cristallo Craquelé
Craquelé glass

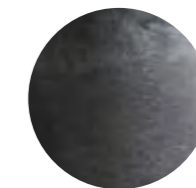

Cristallo verniciato metallo liquido Lava
Liquid metal lacquered Lava glass

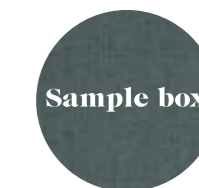

Cristallo brillante/satinato nei colori del campionario
Glass bright/satin version as per sample



▲ **DRIZZLE**
 Struttura in alluminio anodizzato nero /
 Reggipiani in ottone satinato / Piani in cristallo extralight
 Black anodised aluminium structure /
 Satin brass supports / Extralight glass shelves

Drizzle

Luca Nichetto / 2012

Libreria modulare con struttura in alluminio anodizzato nero e reggipiani in ottone satinato. Piani in cristallo extralight temperato 8mm. Disponibile anche in cristallo "grigio Italia" 8mm.

Modular shelving system with black anodised aluminium structure and satin brass shelf supports. 8mm extralight tempered glass shelves. Also available in 8mm smoked "grigio Italia" glass.

! Portata massima del ripiano: 10 kg uniformemente distribuito

! Max capacity of the shelf: 10 kg evenly distributed

Cm

80 x 37,5 x 67,5*
 80 x 37,5 x 114,5*
 80 x 37,5 x 147*
 80 x 37,5 x 194*
 100 x 37,5 x 67,5**
 100 x 37,5 x 114,5**
 100 x 37,5 x 147**
 100 x 37,5 x 194**

Misura dei ripiani

*80 x 34
 **100 x 34

Inches

31½" x 15" x 26¾"
 31½" x 15" x 45¼"
 31½" x 15" x 58"
 31½" x 15" x 76½"
 39½" x 15" x 26¾"
 39½" x 15" x 45¼"
 39½" x 15" x 58"
 39½" x 15" x 76½"

Sizes of the shelves

*31½" x 13½"
 **39½" x 13½"

For technical drawing / p.418

Pricelist 2023 / p.268

STRUTTURA/STRUCTURE



Alluminio anodizzato nero
 Black anodised aluminium

REGGIPIANI/ SUPPORTS



Ottone satinato
 Satin brass

PIANI/SHELVES



Cristallo extralight
 Extralight glass



Cristallo "grigio Italia"
 "Grigio Italia" glass



▲ ISOLA
Struttura in cristallo extralight / Ripiani in ottone satinato
Extralight glass structure / Satin brass shelves

Isola

Massimo Castagna / 2016

Libreria a spalla portante in cristallo extralight 12mm temperato. Disponibile anche in cristallo "grigio Italia" 12mm temperato. Ripiani in ottone satinato oppure in ottone satinato argentato. Borchie tornite e godronate in ottone lucido.

Freestanding shelving system in 12mm extralight tempered glass. Also available in 12mm smoked "grigio Italia" tempered glass. Satin or satin silver-plated brass shelves. Bright brass turned and knurling knobs.

! Non realizzabile su misura.
Portata massima del ripiano: 2kg

! Not available in custom size.
Max capacity of the shelf: 2kg



Cm
61 x 25 x 183
120 x 25 x 183

Inches
24¼" x 10" x 72¼"
47¼" x 10" x 72¼"

For technical drawing / p.418

Pricelist 2023 / p.269

STRUTTURA/STRUCTURE



Cristallo extralight
Extralight glass



Cristallo "grigio Italia"
"Grigio Italia" glass

RIPIANI/SHELVES



Ottone satinato
Satin brass



Ottone satinato argentato
Satin silver-plated brass

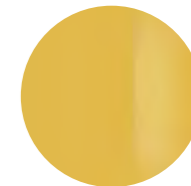

Ottone lucido
Bright brass

DETTAGLI/DETAILS



• ISOLA
Struttura in cristallo "grigioitalia" / Ripiani in ottone satinato
"Grigio Italia" glass structure / Satin brass shelves



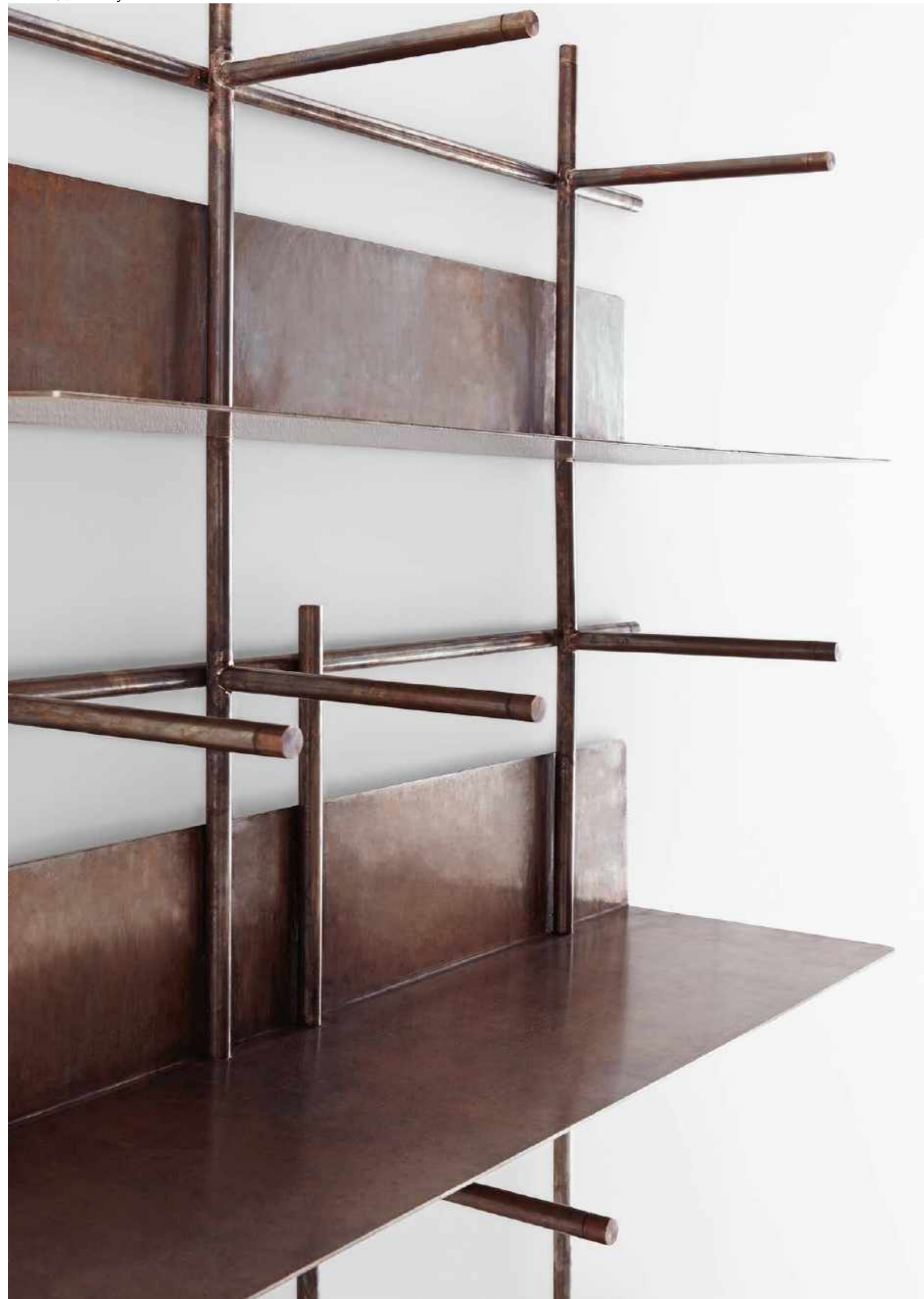

Navigli

Massimo Castagna / 2015

Libreria a muro, con struttura e mensole in rame brunito a mano. Il rame risulta naturalmente macchiato e disomogeneo. Questa lavorazione artigianale conferisce ad ogni pezzo una particolare unicità, rendendolo esclusivo. Disponibile in due versioni A e B.

! Portata massima della mensola: 5 kg con muro pieno, uniformemente distribuiti

NOTE TECNICHE SUI MATERIALI

RAME BRUNITO A MANO | Il rame brunito a mano è ottenuto da un processo di ossidazione naturale eseguito manualmente. Il risultato di questa lavorazione è un prodotto che può presentare macchie e variazioni di colore che non sono da considerarsi imperfezioni ma caratteristiche che conferiscono ad ogni pezzo una particolare unicità, rendendolo esclusivo.

Wall shelving system with hand burnished copper structure and shelves. The hand burnished copper finish looks naturally spotted and irregular. Due to this craftmade processing, each product is unique and exclusive. Available in two versions A and B.

! Max capacity of the shelf: 5 kg on solid wall evenly distributed

TECHNICAL INFORMATION ON THE MATERIALS

HAND BURNISHED COPPER | The hand burnished copper is the consequence of handmade process of natural oxidation. The result of this processing is a product that may show marks and colour variations. These differences are inevitable and should not be considered imperfections but evidence of the hand-crafted process. They enhance the beauty and distinctiveness of a unique piece.



A



B

	Cm	Inches
A	70 x 24 x 120	27 ³ / ₄ " x 9 ¹ / ₂ " x 47 ¹ / ₄ "
B	70 x 24 x 120	27 ³ / ₄ " x 9 ¹ / ₂ " x 47 ¹ / ₄ "

[For technical drawing / p.418](#)

[Pricelist 2023 / p.270](#)
[Homescapes, sense of materials / p.111](#)
[Homescapes, embracing beauty / p.105](#)

STRUTTURA E MENSOLE/STRUCTURE AND SHELVES

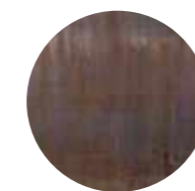

Rame brunito a mano
Hand burnished copper



Pleiadi

Sutdiopepe/2023

Rivestimento decorativo realizzato in linters di cotone e argille e ottenuto tramite un processo di lavorazione artigianale a freddo. Può essere posizionato sia orizzontalmente che verticalmente per creare diverse composizioni e effetti grafici. Disponibile nel colore "nature". Trattandosi di un prodotto realizzato artigianalmente e manualmente, le dimensioni potrebbero variare leggermente.

Decorative wallcovering made of cotton linters and clays and obtained through a cold craft process. Can be placed both horizontally and vertically to create different compositions and graphic effects. Available in 'nature' colour. As this is a handcrafted and manually made product, the dimensions may vary slightly.

NOTE TECNICHE SUI MATERIALI

FINITURE ARTIGIANALI | Le finiture manuali ed esclusive risultato del processo di ossidazione di foglia argento, oro e rame possono presentare macchie e striature, oltre a differenze cromatiche. Tali disomogeneità sono caratteristiche che non devono essere considerate difetti ma elementi distintivi, tipici dell'ossidazione manuale, che esaltano la bellezza e la peculiarità del pezzo unico.

TECHNICAL INFORMATION ON THE MATERIALS

ARTISANAL FINISHES | Artisanal and exclusive finishes that are obtained from the oxidation of silver, gold and copper leaves may show marks and spots, as well as variations in colour. These differences are inevitable and should not be considered imperfections but evidence of the hand-crafted process. They enhance the beauty and distinctiveness of a unique piece.



Cm
20 x 3 x 20

Inches
8" x 1¼" x 8"

For technical drawing / p. 419

Pricelist 2023 / p. 271



"Nature"



▲ **PRISM DIVIDER**
 Legno Noce "Colore" Frisé/Dettagli ottone satinato
 "Colore" Frisé Walnut wood/Satin brass details

Prism Divider

David/Nicolas / 2021

Libreria a colonna modulare in legno Noce Colore Frisé o frassino tinto nero poro aperto. Parti metalliche in ottone satinato. Disponibile versione a due e a tre ripiani. Affiancando due o più colonne si possono creare composizioni di diverse dimensioni.

! Eventuali composizioni sono da comunicare al momento dell'ordine.

Il legno è un materiale vivo che subisce un naturale processo di ossidazione che può causare cambiamenti cromatici. Venature e tonalità di colore differenti delle lastre non sono da considerarsi come difetti, ma caratteristiche che esaltano l'unicità del materiale.

NOTE TECNICHE SUI MATERIALI

INTARSIO | L'intarsio è una tecnica di lavorazione artigianale utilizzata per ottenere un particolare disegno e si realizza accostando elementi di materiali differenti (come legno e alluminio) oppure dello stesso materiale. Questa lavorazione rende il prodotto unico ed esclusivo. Le eventuali variazioni cromatiche e di venatura del legno sono da considerarsi caratteristiche del materiale stesso e non possono essere controllate.

Modular column bookcase in "Colore" Frisé Walnut or black open pore stained ash. Satin brass metal parts. Available with two or three shelves. Placing together two or more modules allow to create various compositions.

! Compositions are to be specified when ordering.

Wood is a living material and the natural oxidation process can cause chromatic changes. Different grain and colour shades of the wooden slabs are not to be considered as defects, but characteristics that enhance the uniqueness of the material.

TECHNICAL INFORMATION ON THE MATERIALS

INLAY | Inlay is an artisanal technique used to obtain a particular design and is made by combining elements of different materials (such as wood and aluminium) or of the same material. This process makes the product unique and exclusive. Any colour and grain variations of the wood are to be considered as characteristics of the material itself and cannot be controlled.



	Cm	Inches
A53	53 x 40 x 183	21" x 15¾" x 72¼"
A83	83 x 40 x 183	32¾" x 15¾" x 72¼"
B53	53 x 40 x 183	21" x 15¾" x 72¼"
B83	83 x 40 x 183	32¾" x 15¾" x 72¼"

For technical drawing / p.419

Pricelist 2023 / p.272
 Homescapes, intimate portraits/ p.65,102
 Homescapes, gentle attitude / p.45

STRUTTURA / STRUCTURE



Legno Noce "Colore" Frisé
 "Colore" Frisé Walnut wood

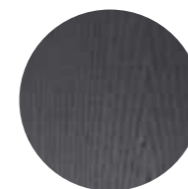

Frassino tinto nero poro aperto
 Black open pore stained ash

DETTAGLI / DETAILS



Ottone satinato
 Satin brass



A53



A83



B53



B83

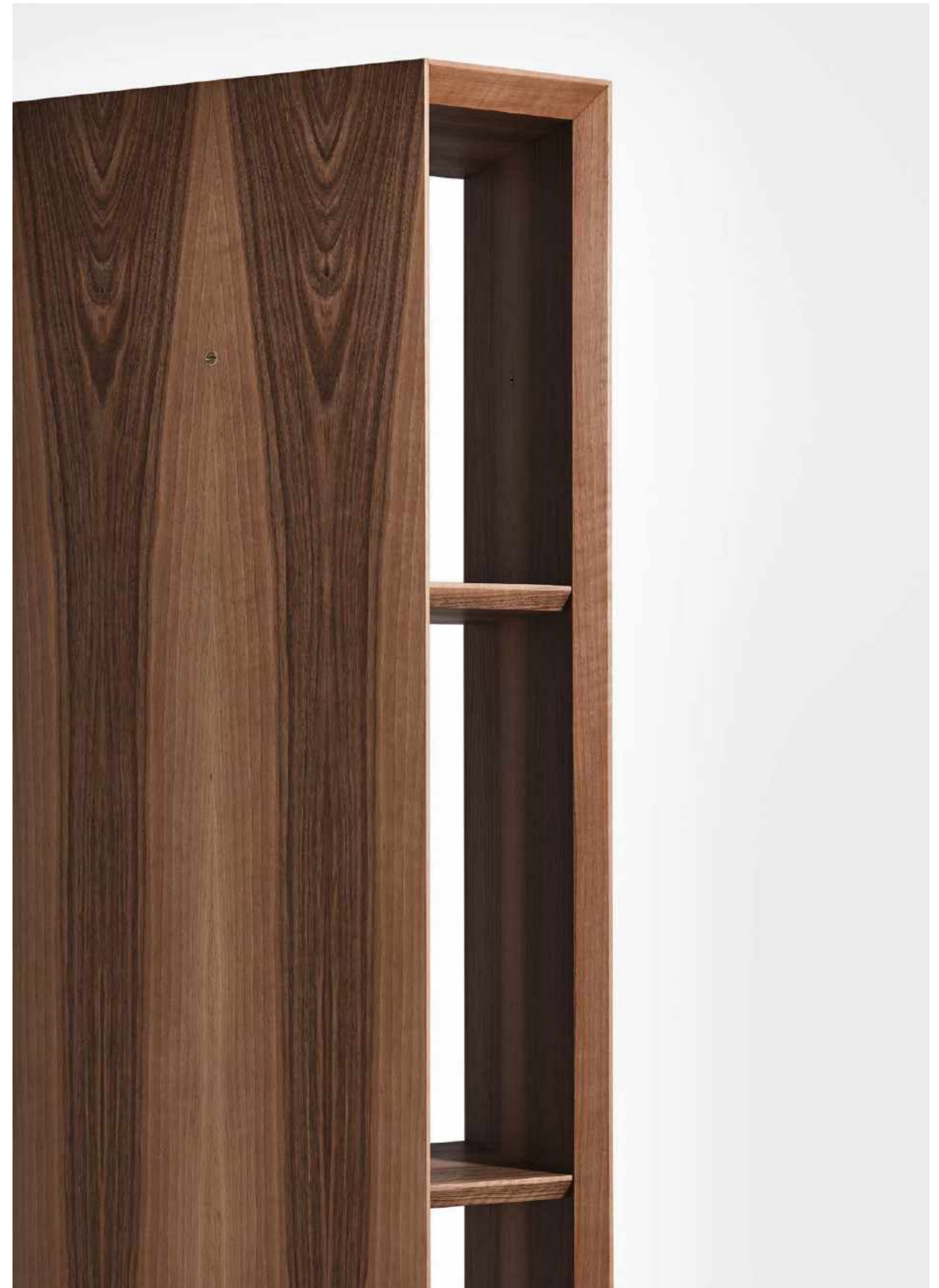

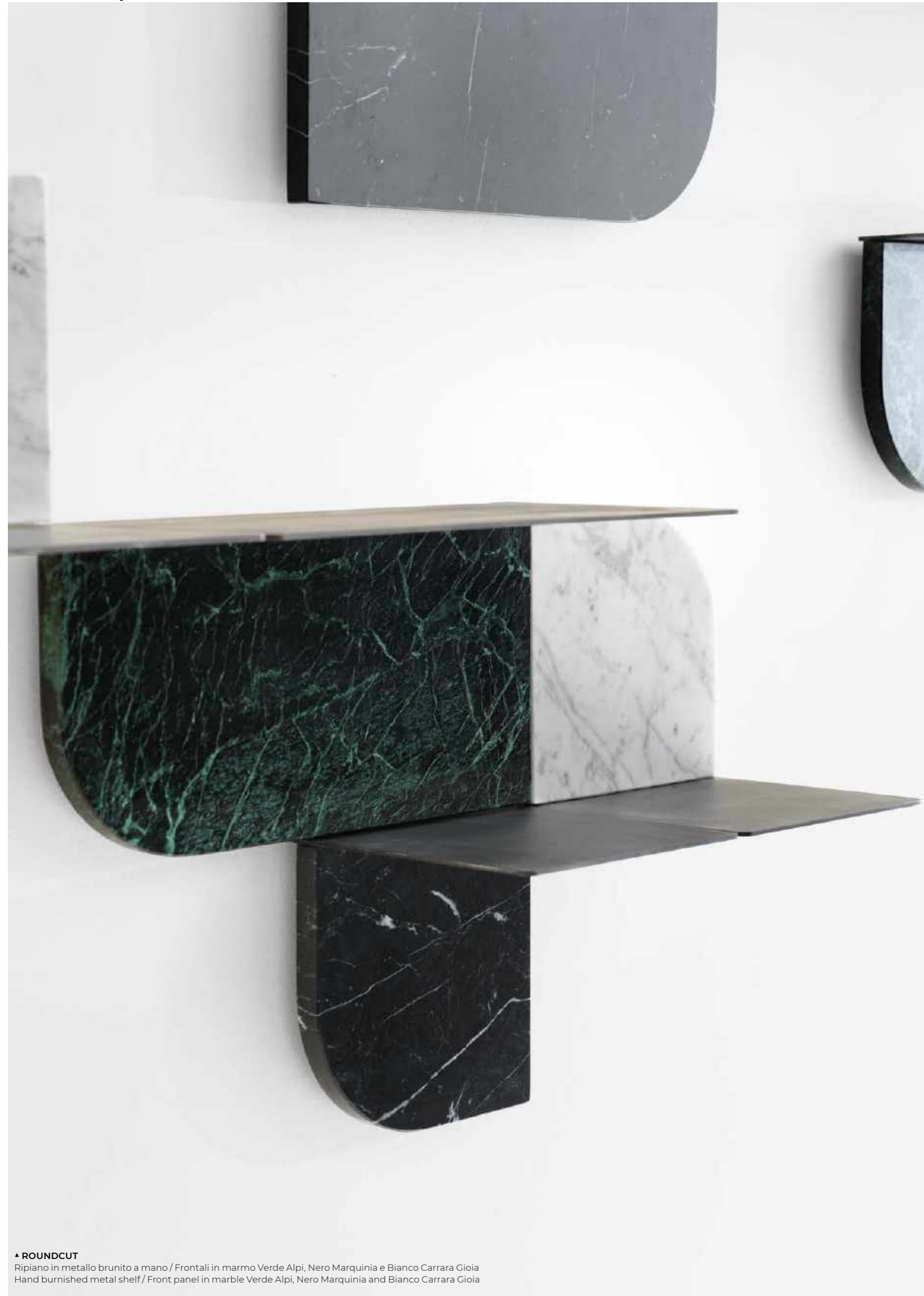

▲ **ROUND CUT**
Ripiano in metallo brunito a mano / Frontali in marmo Verde Alpi, Nero Marquinia e Bianco Carrara Gioia
Hand burnished metal shelf / Front panel in marble Verde Alpi, Nero Marquinia and Bianco Carrara Gioia

Roundcut

Studiopepe/2020

Sistema modulare di mensole con ripiano in metallo brunito a mano. Frontale in marmo a scelta tra Bianco Carrara Gioia lucido naturale, Calacatta Vagli Oro lucido naturale, Stardust Grey lucido naturale, Verde Alpi lucido naturale, Nero Marquinia lucido naturale, Fior di Pesco spazzolato, Travertino Romano spazzolato, "Ceppo dei Volpi" lucido naturale, "Ceppo Antico" lucido naturale oppure disponibile in specchio extralight 6mm. Versione sinistra (L) e destra (R) per ciascuna misura. Le mensole possono essere installate in due diverse posizioni (con mensola sopra o sotto), ruotandole di 180°.

! Portata massima della mensola:
Small=5 kg
Medium=8 kg
Large=10 kg

NOTE TECNICHE SUI MATERIALI

MARMO/TRAVERTINO | Il marmo è un materiale naturale di origine sedimentaria che può presentare particolarità come venature, lievi irregolarità superficiali, colorazioni differenti e cristallizzazioni. Queste peculiarità sono da attribuirsi alla naturalezza del materiale e non sono da considerarsi difetti ma caratteristiche tipiche del marmo. Ogni prodotto risulterà unico, esclusivo e non replicabile.

Modular shelving system with shelf in hand burnished metal. Front panel in marble available in natural polished Bianco Carrara Gioia, natural polished Calacatta Vagli Oro, natural polished Stardust Grey, natural polished Verde Alpi, natural polished Nero Marquinia, brushed Fior di Pesco, brushed Travertino Romano, natural polished "Ceppo dei Volpi", natural polished "Ceppo Antico" or in 6mm extralight mirror. Each size available in the left (L) and right (R) versions. Shelves may be fitted in two locations (with shelf above or below) rotating them by 180°.

! Max capacity of the shelf:
Small=5 kg
Medium=8 kg
Large=10 kg

TECHNICAL INFORMATION ON THE MATERIALS

MARBLE /TRAVERTINO | The marble is a natural material of sedimentary origin that can present particularities such as veins, slight surface irregularities, different colors and crystallizations. These peculiarities are to be attributed to the naturalness of the material and are not to be considered defects but typical characteristics of marble. Each product will be unique, exclusive and non-replicable.



	Cm	Inches
Small L/R	20 x 20 x 20	8" x 8" x 8"
Medium L/R	40 x 20 x 20	15¾" x 8" x 8"
Large L/R	80 x 20 x 20	31½" x 8" x 8"

For technical drawing / p.421

Pricelist 2023 / p. 274

Homescapes, embracing beauty / p.18
Homescapes, gentle attitude / p. 51

RIPIANO/SHELF



Metallo brunito a mano "dark"
"Dark" hand burnished metal

FRONTALE/FRONT PANEL



Marmo lucido naturale Bianco Carrara Gioia
Natural polished Bianco Carrara Gioia marble



Marmo lucido naturale Calacatta Vagli Oro
Natural polished Calacatta Vagli Oro marble



Marmo lucido naturale Stardust Grey
Natural polished Stardust Grey marble



Marmo lucido naturale Verde Alpi
Natural polished Verde Alpi marble



Marmo lucido naturale Nero Marquinia
Natural polished Nero Marquinia marble



Marmo spazzolato Fior di Pesco
Brushed Fior di Pesco marble



Travertino Romano spazzolato
Natural brushed Travertino Romano



Marmo lucido naturale "Ceppo dei Volpi"
Natural polished "Ceppo dei Volpi" marble



Marmo lucido naturale "Ceppo Antico"
Natural polished "Ceppo Antico" marble

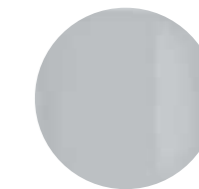

Specchio extralight
Extralight mirror



Syil

Oscar e Gabriele Buratti / 2019

Sistema con montanti in alluminio anodizzato nero con dettagli in ottone lucido. Ripiani sagomati in cristallo grigio Italia 8mm temperato retroverniciato nero brillante. Contenitori ad anta, ribalta o cassetto in legno laccato lucido nei colori blu grigio, liquirizia e nero. Interno in frassino tinto nero poro aperto. Contenitore ad anta con ripiano interno in cristallo extralight temperato 8mm. Disponibile anche modulo con pannello porta tv con contenitore a ribalta. Su richiesta può essere dotato di passacavi.

Shelving system with black anodised aluminium supports with bright brass details. 8mm tempered shaped bright black painted smoked "grigio Italia" glass shelves. Wooden glossy lacquered door unit, flap door or drawer units in the colours blue-grey, liquorice and black. Black open pore stained ash interior. Door unit with 8mm tempered inside extralight glass. Also available module with Tv panel and flap door unit, supplied with cable management, on request.

! Consigliato fissaggio a parete con ferramenta inclusa.

! Recommended wall fixing with included hardware.



Cm

123 x 47 x 70
123 x 47 x 132
123 x 47 x 158
183 x 47 x 158
123 x 47 x 194
183 x 47 x 194
123 x 47 x 256
183 x 47 x 256

Inches

48½" x 18¾" x 23¾"
48½" x 18¾" x 52"
48½" x 18¾" x 62¼"
72¼" x 18¾" x 62¼"
48½" x 18¾" x 76½"
72¼" x 18¾" x 76½"
48½" x 18¾" x 101"
72¼" x 18¾" x 101"

For technical drawing / pp.422-428

Pricelist 2023 / p. 277
Homescapes, sense of materials / p. 8
Homescapes, embracing beauty / pp. 39,41
Homescapes, gentle attitude / p. 90

MONTANTI/SUPPORTS



Alluminio anodizzato nero
Black anodised aluminium

DETTAGLI/DETAILS

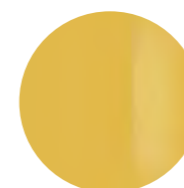

Ottone lucido
Bright brass

RIPIANI/SHELVES

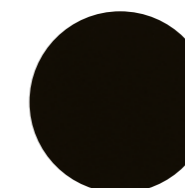

Cristallo "grigio Italia"
retroverniciato nero
brillante
Bright black painted
smoked "grigio Italia" glass

RIPIANO INTERNO/ INSIDE SHELVES



Cristallo extralight
Extralight mirror

CONTENITORI/UNITS

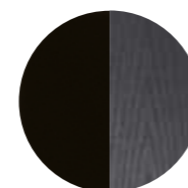

Esterno- legno laccato
lucido nero /
Interno- frassino tinto
nero poro aperto
Outside- glossy lacquered
black wood /
Inside- black open pore
lacquered ash

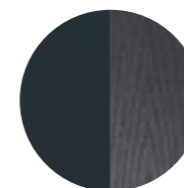

Esterno- legno laccato
lucido blu-grigio /
Interno- frassino tinto
nero poro aperto
Outside- glossy lacquered
blue-grey wood /
Inside- black open pore
lacquered ash

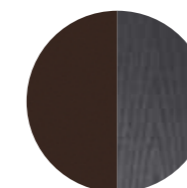

Esterno- legno laccato
lucido liquirizia /
Interno- frassino tinto
nero poro aperto
Outside- glossy lacquered
liquorice wood /
Inside- black open pore
lacquered ash



▲ **TORTONA**
Struttura in metallo verniciato bronzo patinato / Piani cristallo stopsol bronzo
Patinated bronze lacquered metal structure / Stopsol bronze glass

Tortona

Massimo Castagna / 2014

Libreria in metallo verniciato bronzo patinato. Piani in cristallo 8mm stopsol bronzo o extralight temperato. Su richiesta disponibile top con marmo lucido naturale Calacatta Vagli Oro incassato (solo per le versioni cm 65h e cm 92h).

Shelving system in patinated bronze lacquered metal. 8mm bronze stopsol or extralight tempered glass shelves. Top also available with recessed natural polished Calacatta Vagli Oro marble (only for the versions 65h cm and 92h cm, on request).

NOTE TECNICHE SUI MATERIALI

MARMO | Il marmo è un materiale naturale di origine sedimentaria che può presentare particolarità come venature, lievi irregolarità superficiali, colorazioni differenti e cristallizzazioni. Queste peculiarità sono da attribuirsi alla naturalezza del materiale e non sono da considerarsi difetti ma caratteristiche tipiche del marmo. Ogni prodotto risulterà unico, esclusivo e non replicabile. I nostri marmi vengono trattati con un prodotto idrorepellente che permette una maggiore protezione della superficie stessa, aumentando l'impermeabilità. Questo trattamento non esclude la vulnerabilità del marmo alle sostanze acide.

TECHNICAL INFORMATION ON THE MATERIALS

MARBLE | The marble is a natural material of sedimentary origin that can present particularities such as veins, slight surface irregularities, different colors and crystallizations. These peculiarities are to be attributed to the naturalness of the material and are not to be considered defects but typical characteristics of marble. Each product will be unique, exclusive and non-replicable. Our marbles are treated with water-repellent products which affords greater protection to the surface of the marble, improving its impermeability. This treatment doesn't exclude the vulnerability of the marble to acid substances.

METALLO E LEGNO - BRONZO PATINATO | Le finiture esclusive, risultato della lavorazione manuale realizzata sul metallo e sul legno, possono presentare striature e differenze cromatiche. Queste caratteristiche non devono essere considerate difetti ma elementi distintivi del processo artigianale che esaltano la bellezza e la peculiarità del pezzo unico.

METAL AND WOOD - PATINATED BRONZE | Exclusive finishes, resulting from the craftsmanship on the metal and wood, may show streaks and chromatic differences. These characteristics should not be considered imperfections but distinctive evidence of the hand-made process that enhance the beauty and peculiarity of the unique piece.



Cm

166 x 37 x 65
239 x 37 x 65
166 x 37 x 92
239 x 37 x 92
166 x 37 x 175
239 x 37 x 175
166 x 37 x 258
239 x 37 x 258

Inches

65½" x 14¾" x 25¾"
94¼" x 14¾" x 25¾"
65½" x 14¾" x 36¼"
94¼" x 14¾" x 36¼"
65½" x 14¾" x 69"
94¼" x 14¾" x 69"
65½" x 14¾" x 101¾"
94¼" x 14¾" x 101¾"

[For technical drawing / p.429](#)

[Pricelist 2023 / p. 292](#)
[Homescapes, sense of materials / p. 51](#)

STRUTTURA/STRUCTURE



Metallo verniciato bronzo patinato
Patinated bronze lacquered metal

PIANI/SHELVES



Cristallo stopsol bronzo
Stopsol bronze glass



Cristallo extralight
Extralight glass

TOP VERSIONE 65H -92H CM



Marmo lucido naturale Calacatta Vagli Oro
Natural polished Calacatta Vagli Oro marble

09

**Librerie e boiserie /
Shelvins system and boiserie**
TECHNICAL MODULE

Brera | Massimo Castagna, 2016

Product information / p. 390

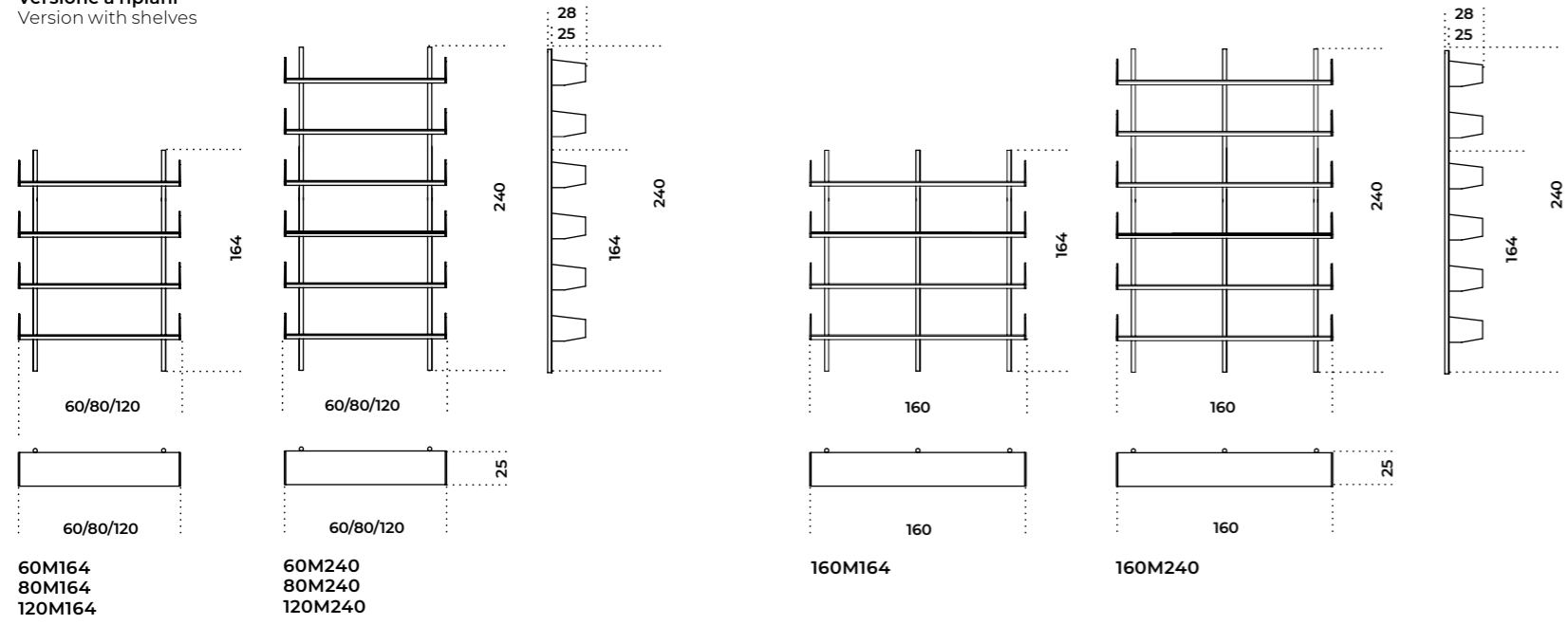
Versione a ripiani
Version with shelves**Brera23** | Massimo Castagna, 2016

Product information / p. 392

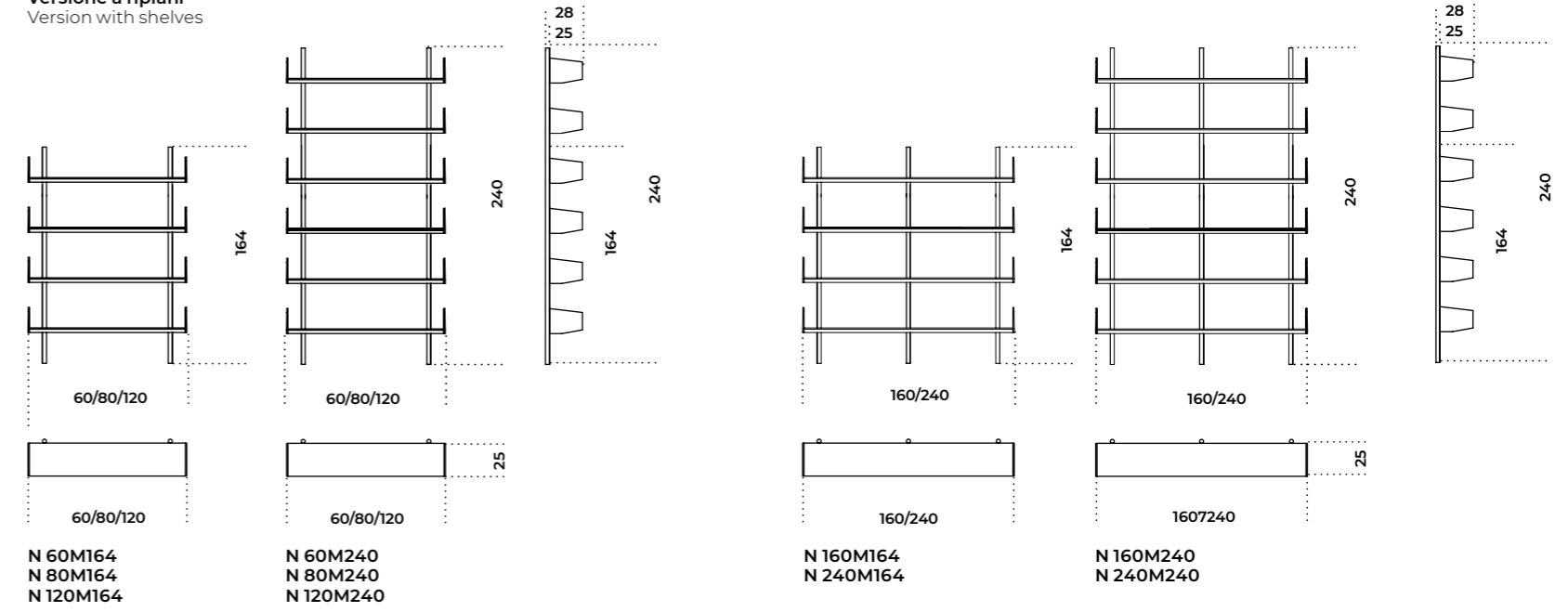
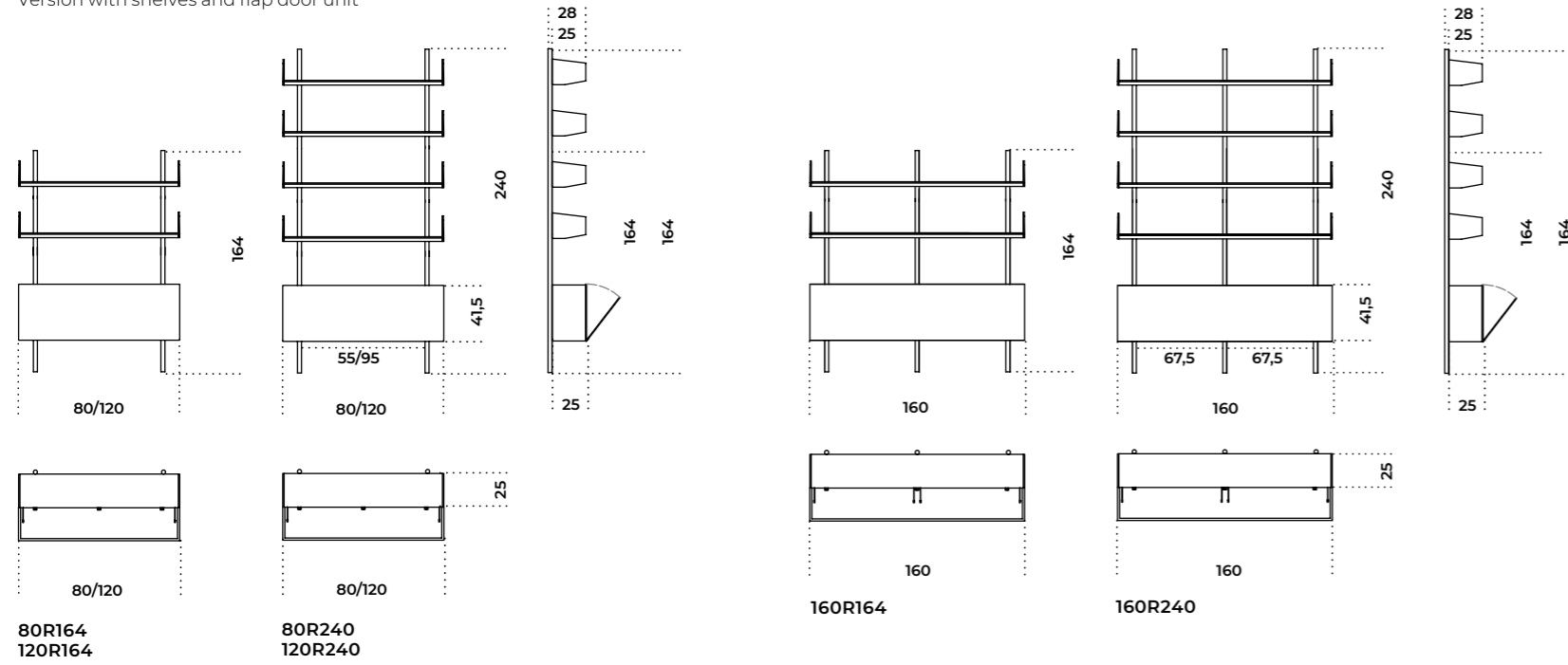
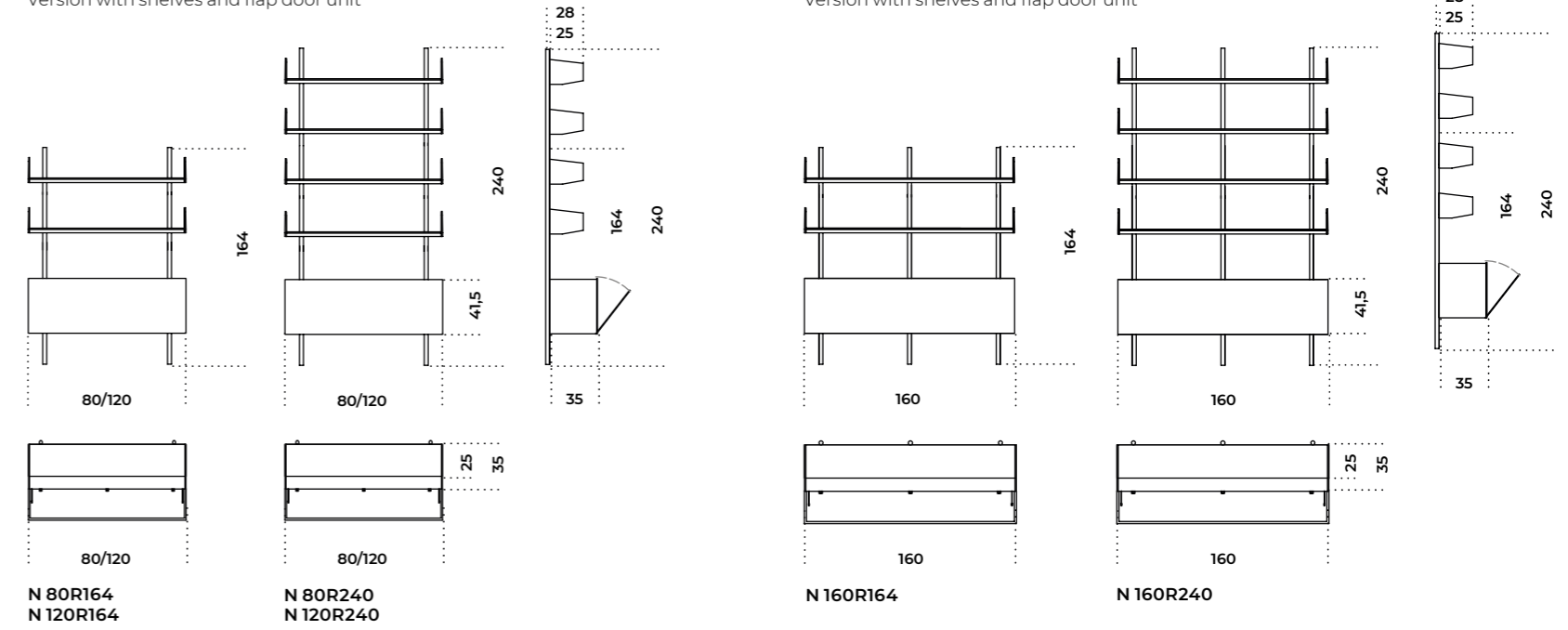
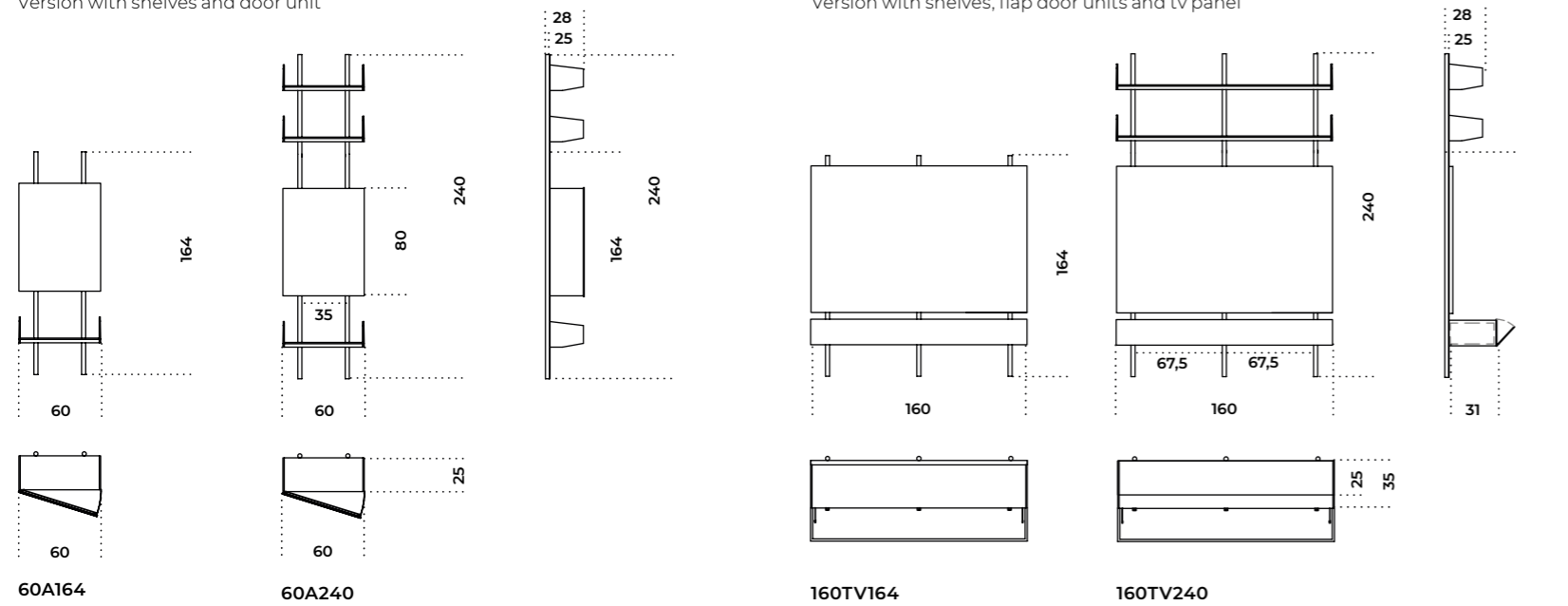
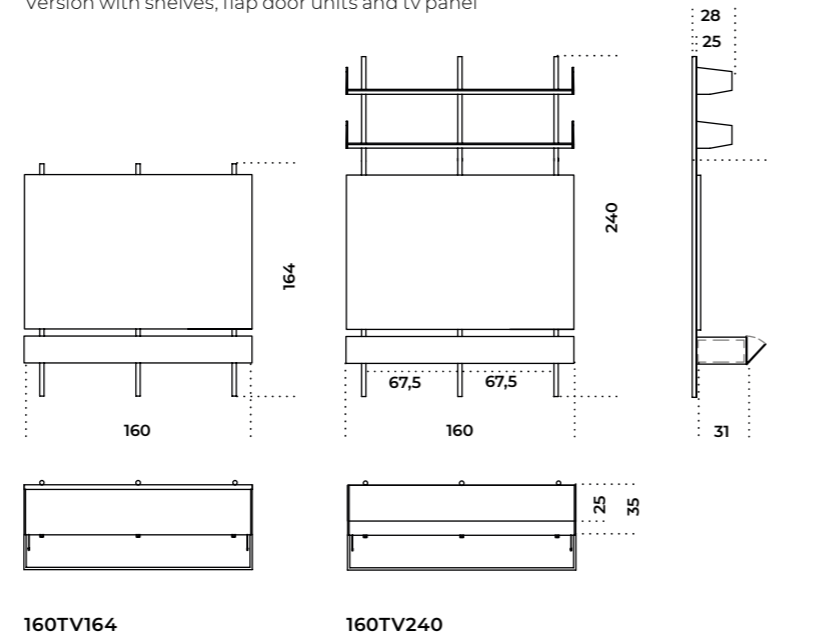
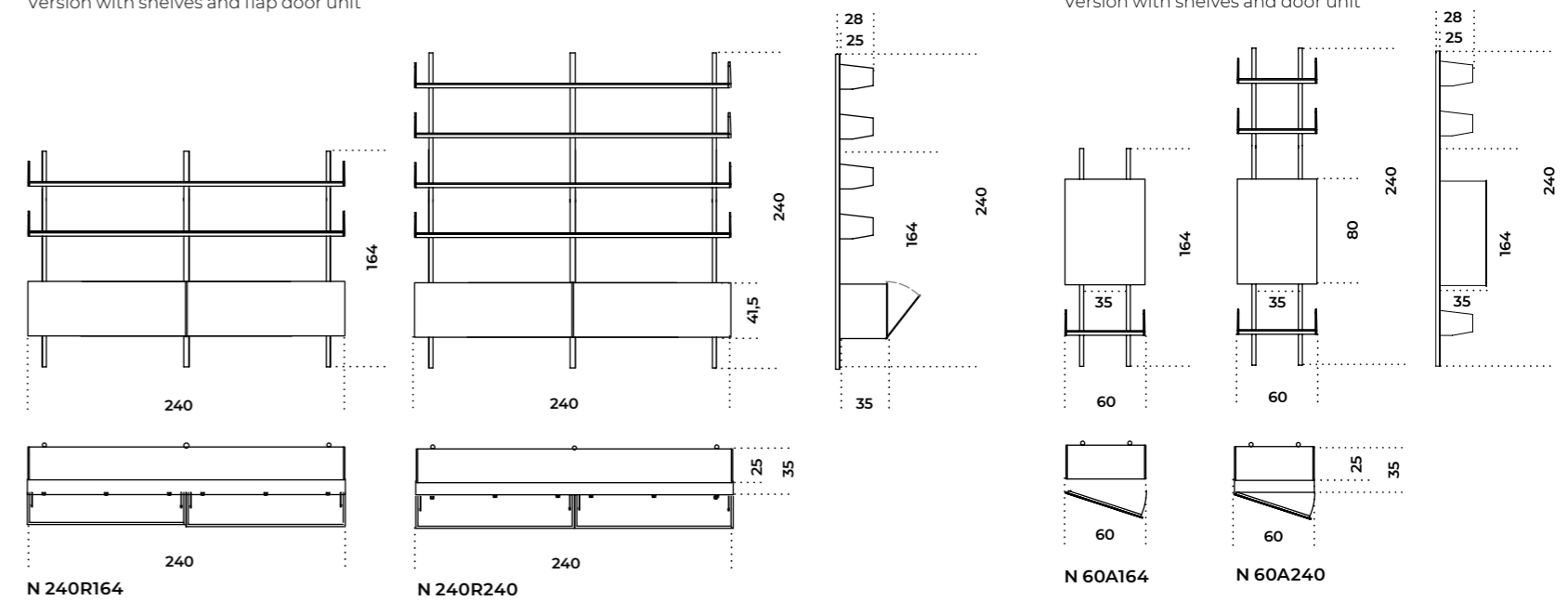
Versione a ripiani
Version with shelves**Versione a ripiani e contenitore a ribalta**
Version with shelves and flap door unit**Versione a ripiani e contenitore a ribalta**
Version with shelves and flap door unit**Versione a ripiani e contenitore ad anta**
Version with shelves and door unit**Versione a ripiani, contenitori a ribalta e pannello tv**
Version with shelves, flap door units and tv panel**Versione a ripiani e contenitore a ribalta**
Version with shelves and flap door unit

Drizzle | Luca Nichetto, 2012

Product information / p. 394

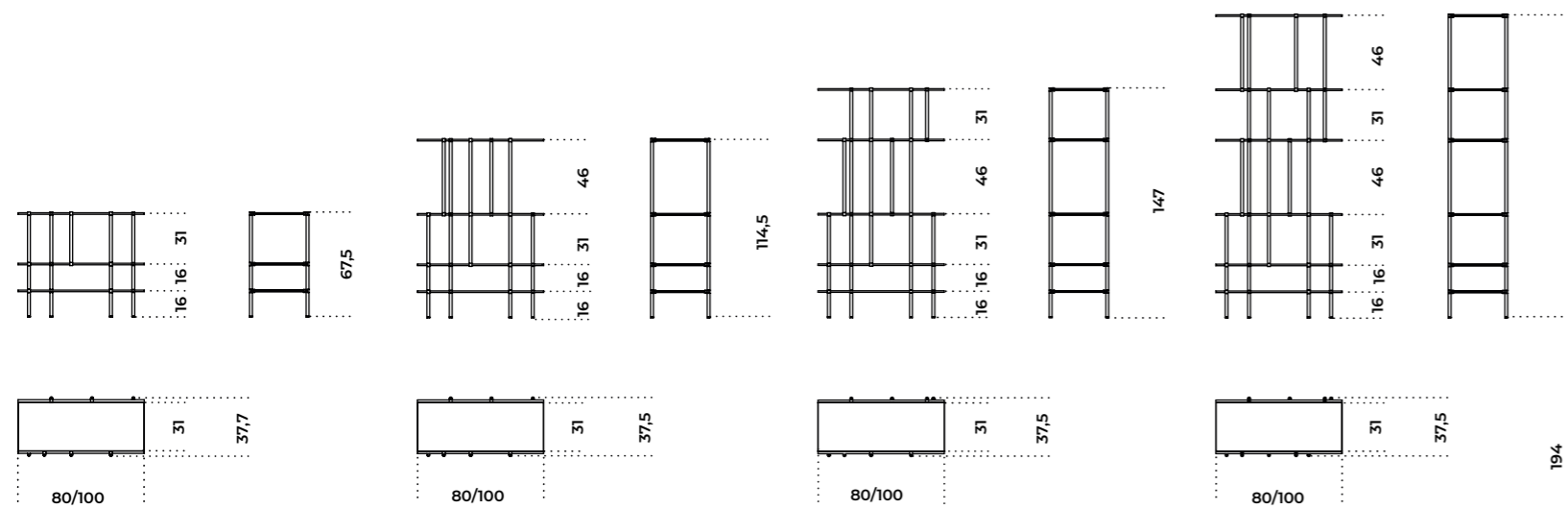

Pleadi | Studiopepe, 2023

Product information / p. 402

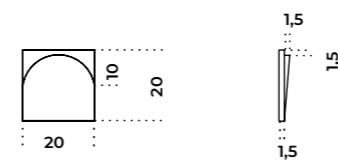

Isola | Massimo Castagna, 2016

Product information / p. 396

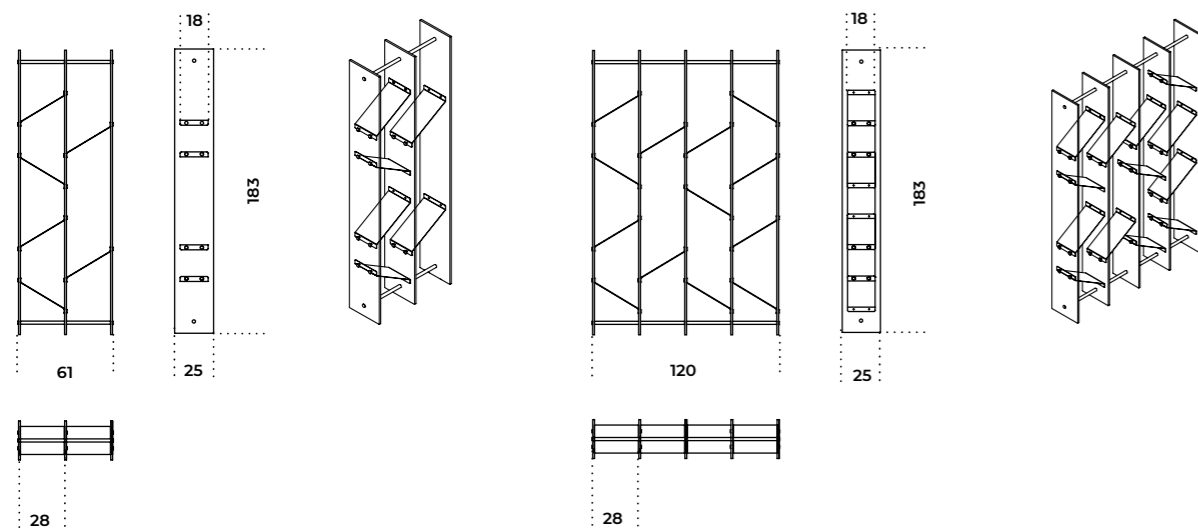

Prism Divider | David/Nicolas, 2021

Product information / p. 404

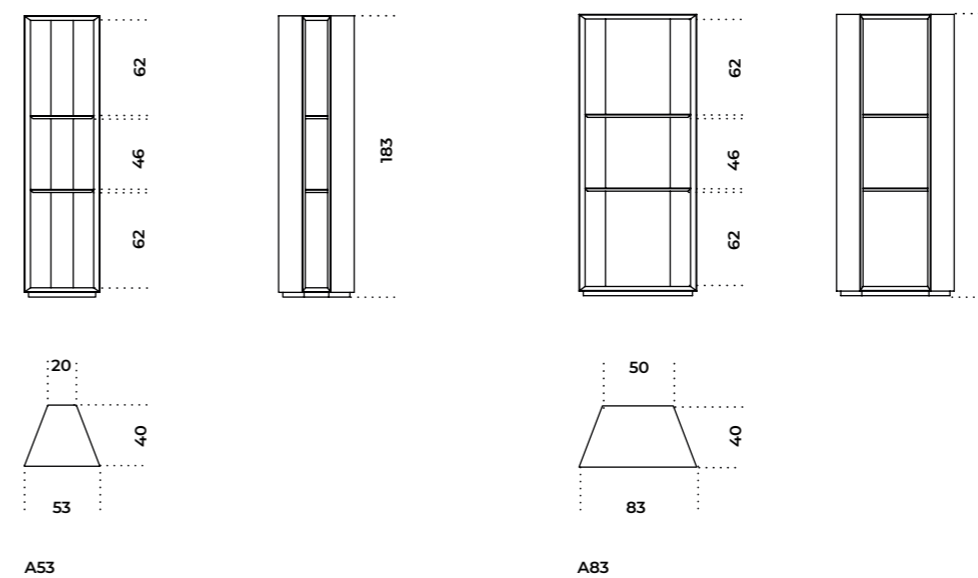

Navigli | Massimo Castagna, 2015

Product information / p. 400

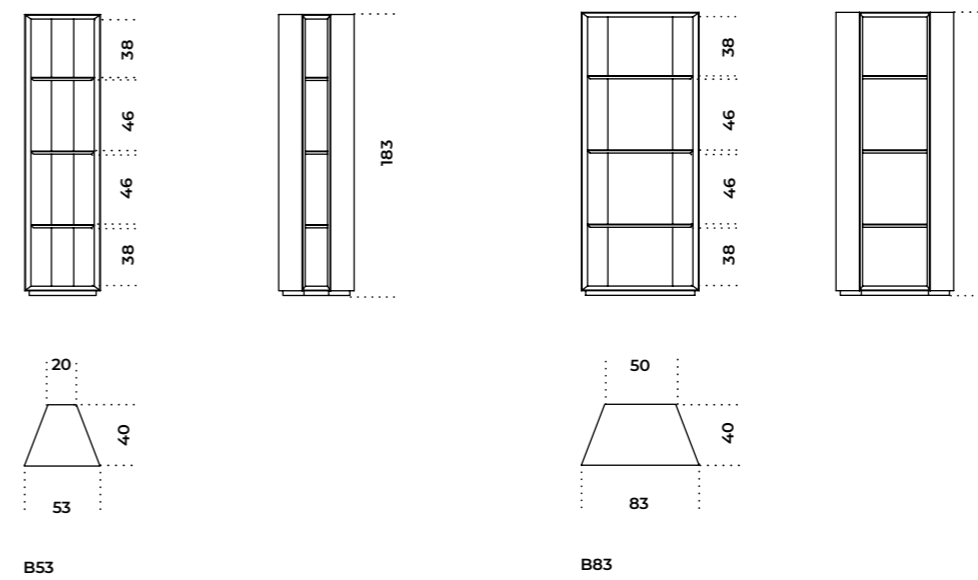
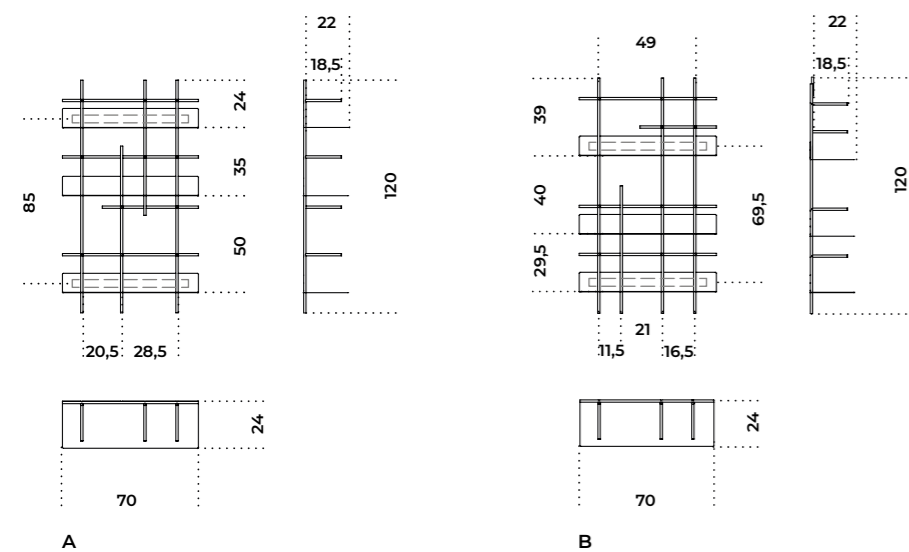

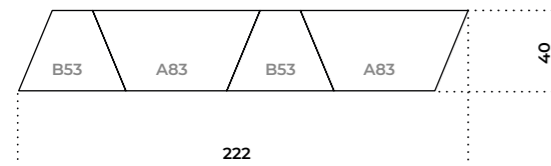
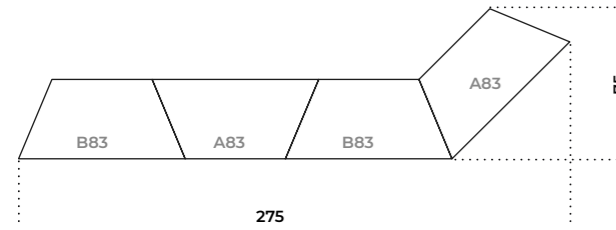
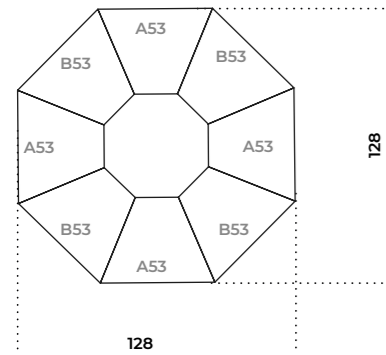
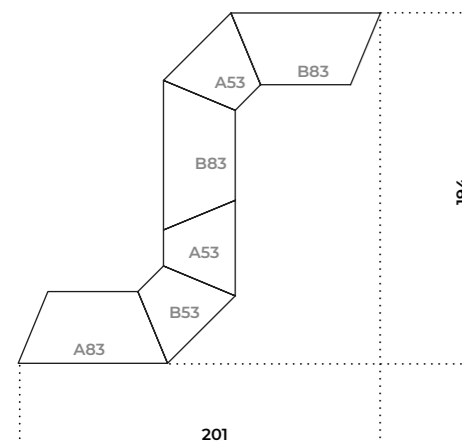
Esempi di composizioni
Composition examples**COMPOSIZIONE 1 / COMBINAZIONE 1**
Composition 1 / Combination 1222 x 40 x 183h
87½" x 15¾" x 72¾"hComposta da
Composed byn. 2 A83
n. 2 B53**COMPOSIZIONE 2 / COMBINAZIONE 2**
Composition 2 / Combination 2275 x 75 x 183h
108½" x 29¾" x 72¾"hComposta da
Composed byn. 2 A83
n. 2 B83**COMPOSIZIONE 3 / COMBINAZIONE 3**
Composition 3 / Combination 3128 x 128 x 183h
50½" x 50½" x 72¾"hComposta da
Composed byn. 4 A53
n. 4 B53**COMPOSIZIONE 4 / COMBINAZIONE 4**
Composition 4 / Combination 4201 x 194 x 183h
79¾" x 76¾" x 72¾"hComposta da
Composed byn. 1 A83
n. 2 A53
n. 1 B53
n. 2 B83

Product information / p. 404

Roundcut | Studiopepe, 2020

Product information / p. 408

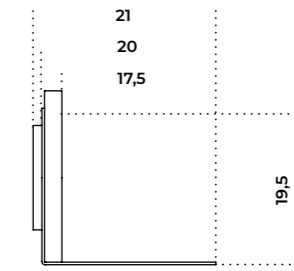
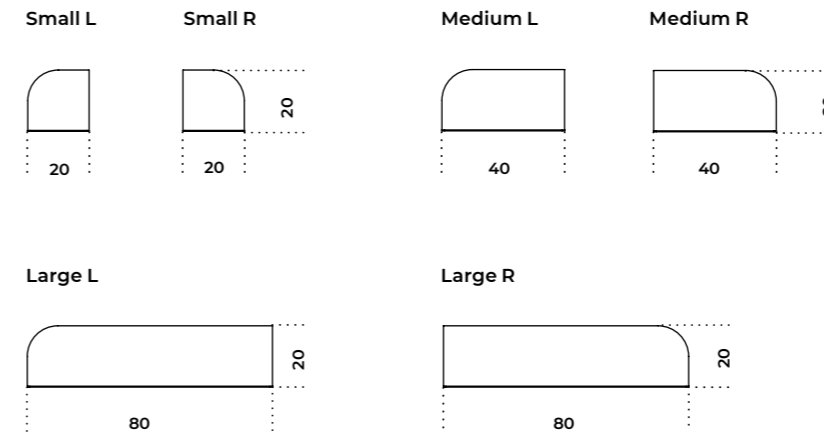
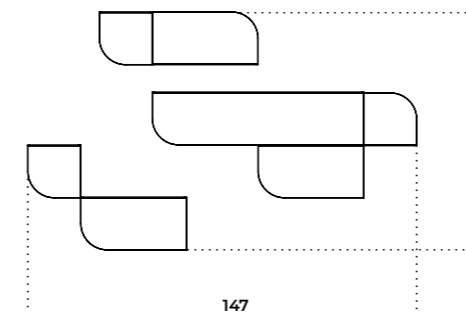
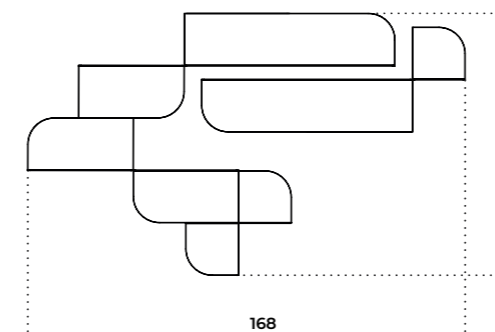
Dettaglio vista laterale
Detail side view**Esempi di composizioni**
Composition examples**COMPOSIZIONE 1 / COMBINAZIONE A**
Composition 1 / Combination AComposta da
Composed byn.2 Small R | Bianco Carrara Gioia
n.1 Small R | Verde Alpi
n.2 Medium R | Bianco Carrara Gioia
n.1 Medium R | Verde Alpi
n.1 Large R | Verde Alpi**COMPOSIZIONE 1 / COMBINAZIONE B**
Composition 1 / Combination BComposta da
Composed byn.2 Small R | Travertino
n.1 Small R | Calacatta Vaghi Oro
n.2 Medium R | Travertino
n.1 Medium R | Calacatta Vaghi Oro
n.1 Large R | Calacatta Vaghi Oro**COMPOSIZIONE 2 / COMBINAZIONE A**
Composition 2 / Combination AComposta da
Composed byn.2 Small R | Travertino
n.1 Small R | Calacatta Vaghi Oro
n.1 Medium R | Stardust grey
n.1 Medium L | Travertino
n.1 Medium L | Calacatta Vaghi Oro
n.2 Large R | Stardust grey**COMPOSIZIONE 2 / COMBINAZIONE B**
Composition 2 / Combination BComposta da
Composed byn.2 Small R | Bianco Carrara Gioia
n.1 Small R | Nero Marquinia
n.1 Medium R | Fior di pesco
n.1 Medium L | Nero Marquinia
n.1 Medium L | Bianco Carrara Gioia
n.2 Large R | Fior di pesco**COMPOSIZIONE 2 / COMBINAZIONE C**
Composition 3 / Combination CComposta da
Composed byn.2 Small R | Bianco Carrara Gioia
n.1 Small R | Nero Marquinia
n.1 Medium R | Verde Alpi
n.1 Medium L | Nero Marquinia
n.1 Medium L | Bianco Carrara Gioia
n.2 Large R | Verde Alpi

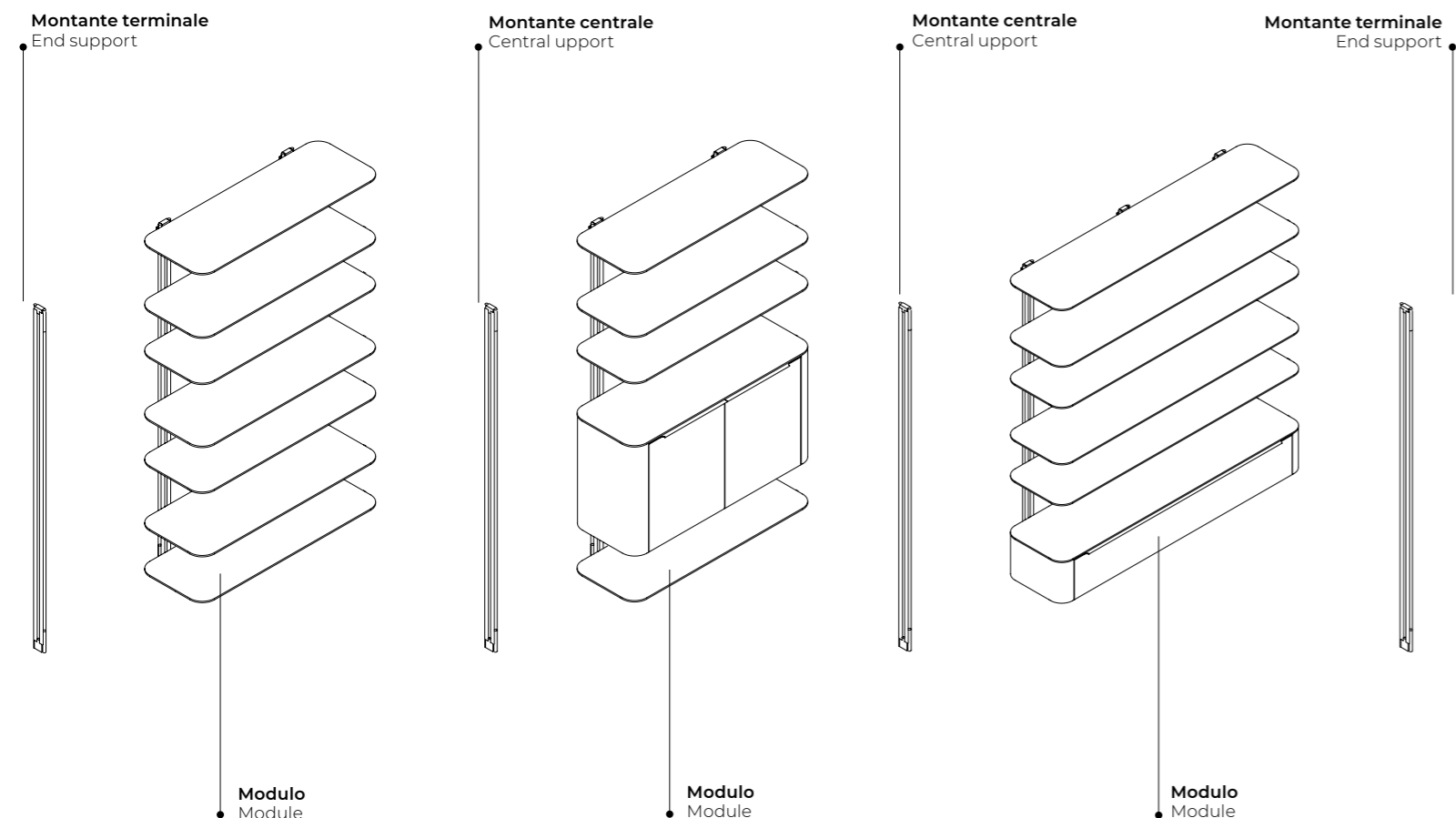

AVVERTENZE
Consigliato fissaggio a parete con ferramenta inclusa.
Viene fornito disegno per approvazione.

WARNINGS
Recommended wall fixing with included hardware.
Drawing is provided for approval.

Esempio di composizione
Composition example

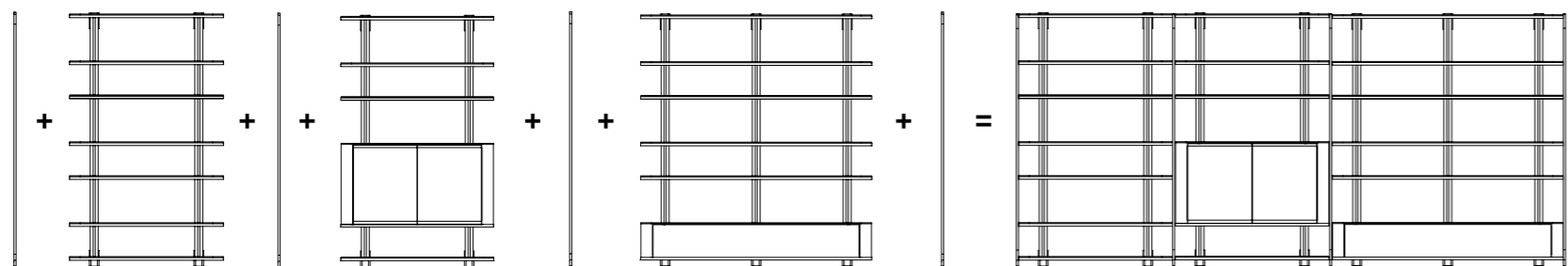

MODULARITÀ
MODULARITY

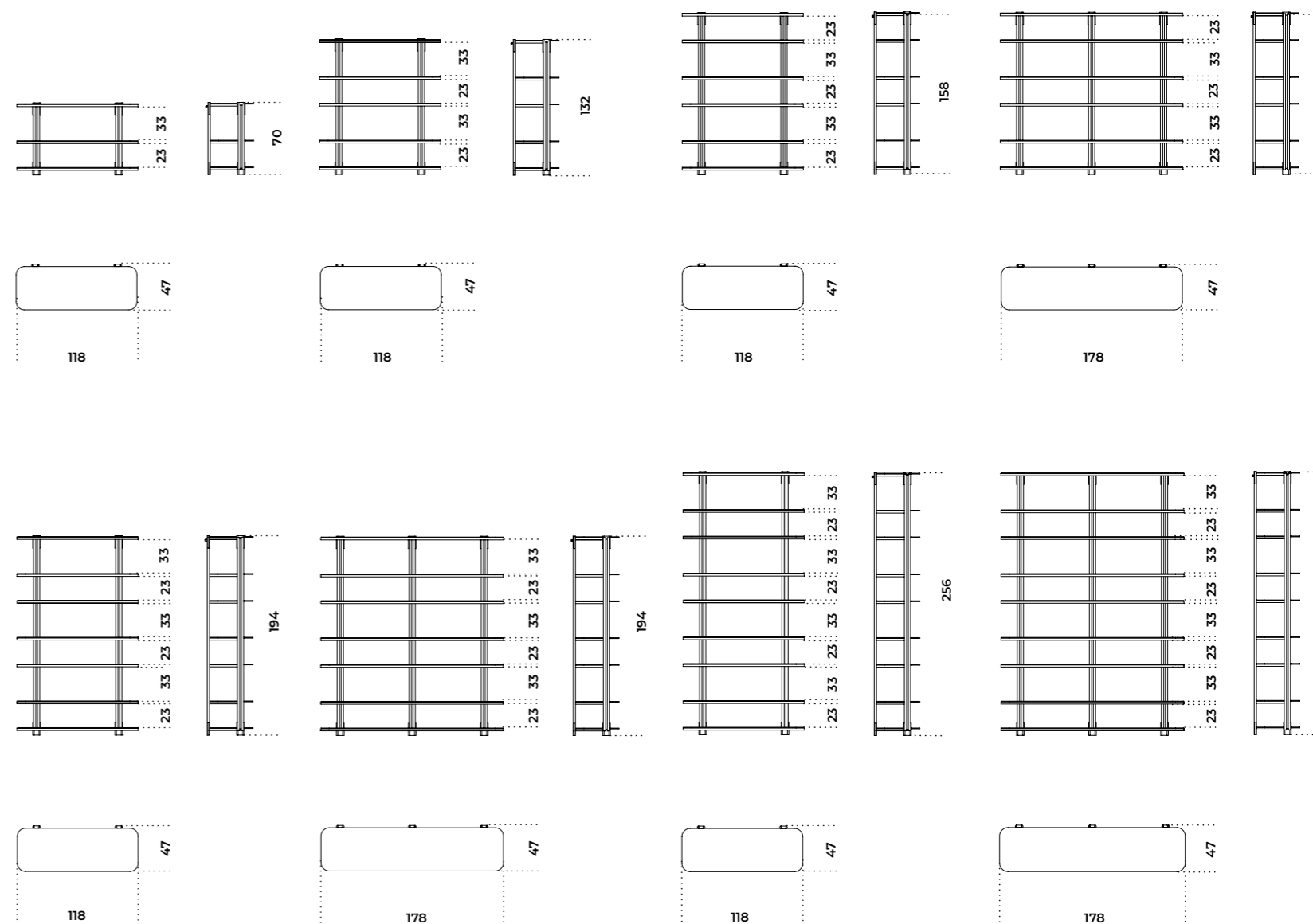

CM/INCHES

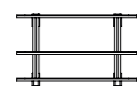
123 x 47 x 70h
48½" x 18¾" x 23¾" h**Mensole**
Shelves**123-M-70**

CM/INCHES

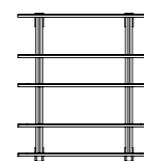
123 x 47 x 132h
48½" x 18¾" x 52" h**Mensole**
Shelves**123-M-132**

CM/INCHES

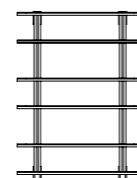
123 x 47 x 158h
48½" x 18¾" x 62¾" h**Mensole**
Shelves**123-M-158**

CM/INCHES

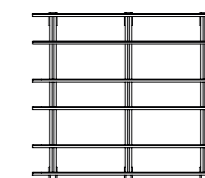
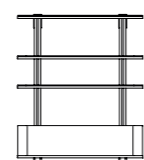
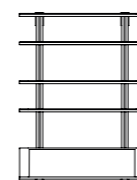
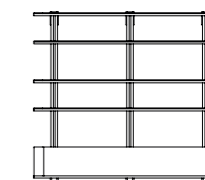
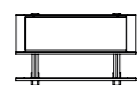
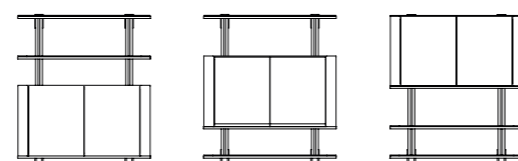
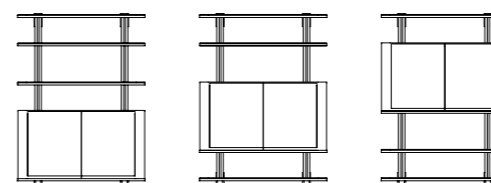
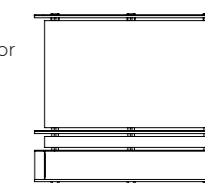
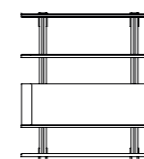
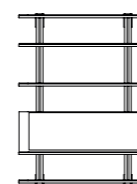
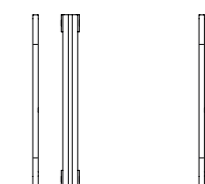
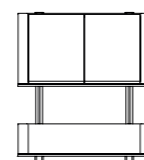
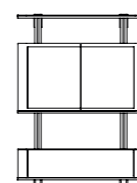
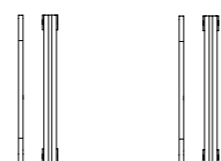
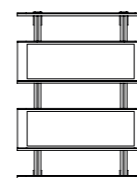
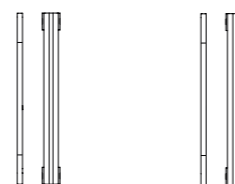
183 x 47 x 158h
72¾" x 18¾" x 62¾" h**Mensole**
Shelves**183-M-158****Mensole + cassetto**
Shelves + drawer**123-C1-70****Mensole + cassetto**
Shelves + drawer**123-C1-132****Mensole + cassetto**
Shelves + drawer**123-C1-158****Mensole + ribalta**
Shelves + flap door**183-R1-158****Mensole + ribalta**
Shelves + flap door**123-R2-70****Mensole + ante**
Shelves + doors**123-A1-132****123-A2-132****123-A3-132****Mensole + ante**
Shelves + doors**123-A1-158****123-A2-158****123-A3-158****Mensole + mobile tv + ribalta**
Shelves + TV unit + flap door**183-R1TV-158****Montante centrale e terminale**
Central and end support**T-70****C-70****Mensole + ribalta**
Shelves + flap door**123-R2-132****Mensole + ribalta**
Shelves + flap door**123-R2-158****Montante centrale e terminale**
Central and end support**T-158****C-158****Mensole + cassetto + ante**
Shelves + drawer + doors**123-C1A3-132****Mensole + cassetto + ante**
Shelves + drawer + doors**123-C1A3-158****Montante centrale e terminale**
Central and end support**T-132****C-132****Mensole + ribalta**
Shelves + flap door**123-R2R4-158****Montante centrale e terminale**
Central and end support**T-158****C-158**

CM/INCHES

123 x 47 x 194h
48½" x 18¾" x 76½"h

Mensole
Shelves

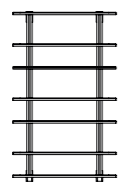

123-M-194

CM/INCHES

183 x 47 x 194h
72¾" x 18¾" x 76½"h

Mensole
Shelves

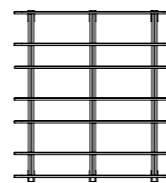

183-M-194

CM/INCHES

123 x 47 x 256h
48½" x 18¾" x 101"h

Mensole
Shelves



123-M-256

CM/INCHES

183 x 47 x 256h
72¾" x 18¾" x 101"h

Mensole
Shelves

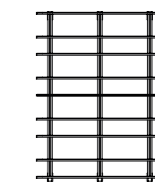

183-M-256

Mensole + cassetto
Shelves + drawer

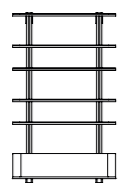

123-C1-194

Mensole + ribalta
Shelves + flap door

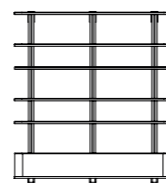

183-R1-194

Mensole + cassetto
Shelves + drawer

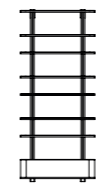

123-C1-256

Mensole + ribalta
Shelves + flap door

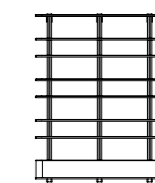

183-R1-256

Mensole + ante
Shelves + doors

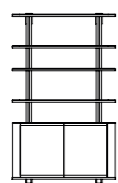

123-A1-194

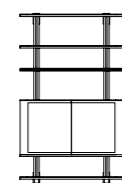

123-A2-194

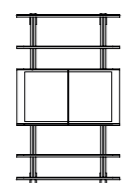

123-A3-194

Mensole + mobile tv
+ ribalta
Shelves + TV unit + flap door

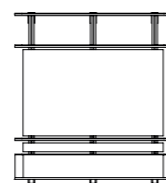

183-RITV-194

Mensole + ante
Shelves + doors

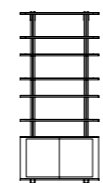

123-A1-256

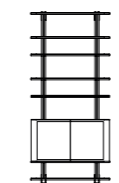

123-A2-256

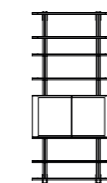

123-A3-256

Mensole + mobile tv
+ ribalta
Shelves + TV unit + flap door

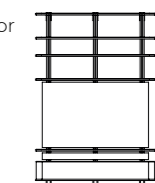

183-RITV-256

Mensole + ribalta
Shelves + flap door

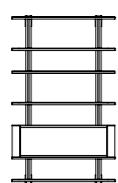

123-R2-194

Montante centrale
e terminale
Central and end support

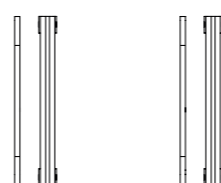

T-194 C-194

Mensole + ribalta
Shelves + flap door

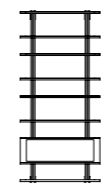

123-R2-256

Montante centrale
e terminale
Central and end support

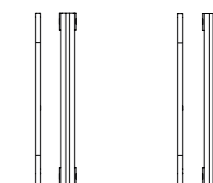

T-256 C-256

Mensole + cassetto + ante
Shelves + drawer + doors

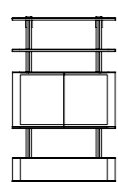

123-C1A3-194

Mensole + cassetto + ante
Shelves + drawer + doors

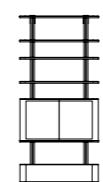

123-C1A3-256

Mensole + ribalta
Shelves + flap door

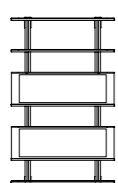

123-R2R4-194

Mensole + ribalta
Shelves + flap door

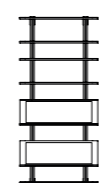

123-R2R4-256

Montante centrale
e terminale
Central and end support

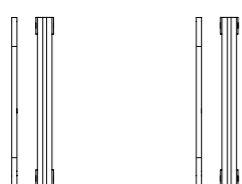

T-194 C-194

Montante centrale
e terminale
Central and end support

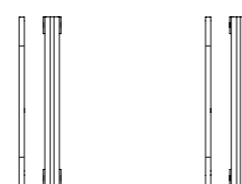

T-256 C-256

COMPOSIZIONI
COMPOSITIONS

COMPOSITION 1

363 x 47 x 70h
143" x 18¾" x 23¾h

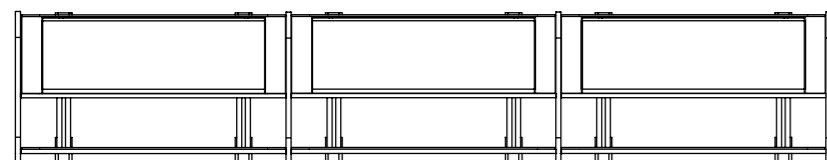

Composta da
Composed by

n. 3 123-R2-70
n. 2 C-70
n. 2 T-70

COMPOSITION 2

243 x 47 x 132h
95¾" x 18¾" x 76½h

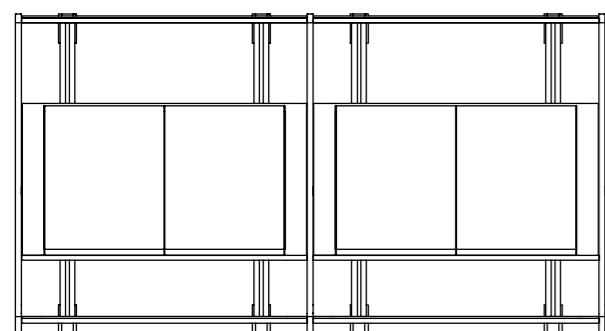

Composta da
Composed by

n. 2 123-A2-132
n. 1 C-132
n. 2 T-132

COMPOSITION 3

303 x 47 x 194h
119½" x 18¾" x 76½h

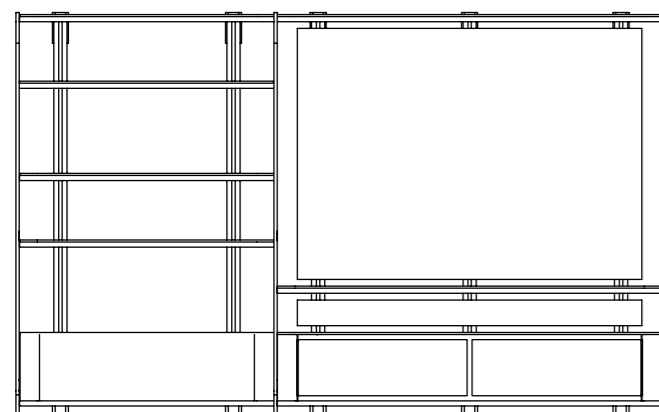

Composta da
Composed by

n. 1 123-C1-194
n. 1 183-R1TV-194
n. 1 C-194
n. 2 T-194

Tortona | Massimo Castagna, 2014

Product information / p. 412

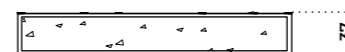
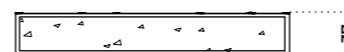
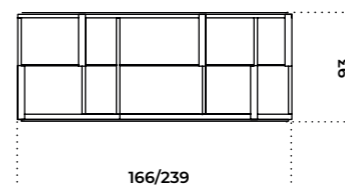
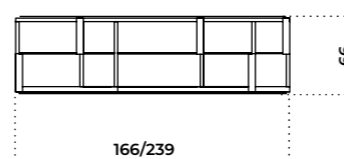
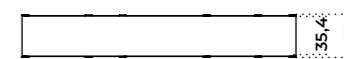
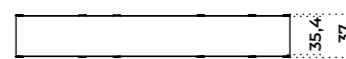
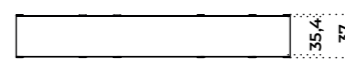
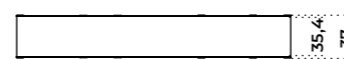
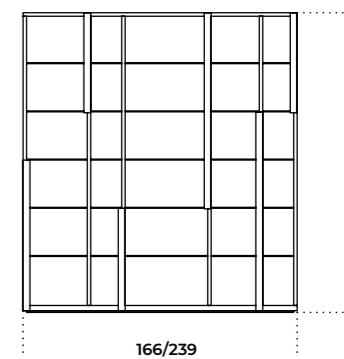
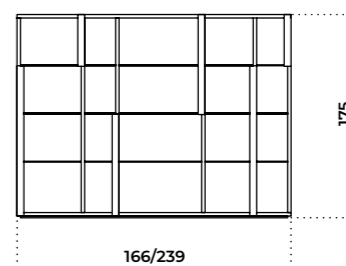
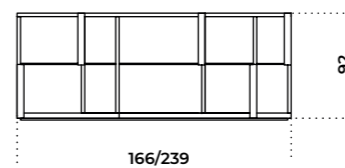
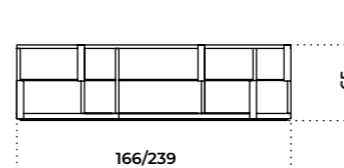

Piano in marmo
Marble top

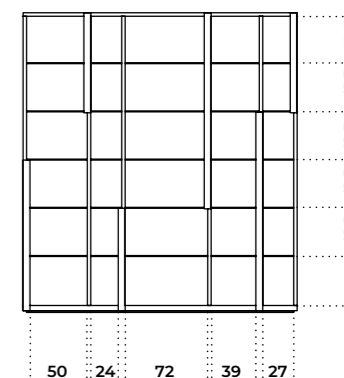
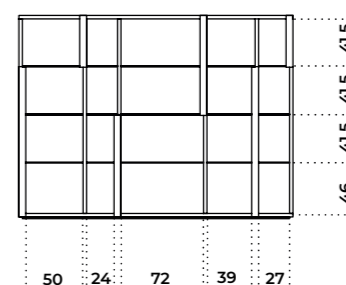
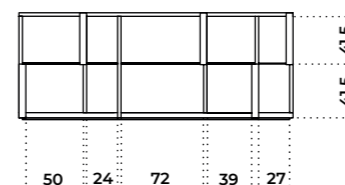
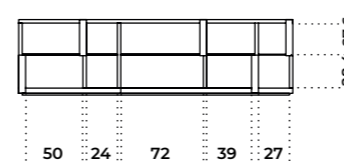

10 **Letti /**
Beds

432 **Eve**
434 **Lilas Bed**
436 **Xeni**
438 **Yuki**

440 **Informazioni tecniche/**
Technical informations

Eve

Pietro Russo / 2021

Letto con testata boiserie in legno Noce "Colore" Frisé intarsiato a spina di pesce con pannelli laterali orientabili. Giroletto sfoderabile imbottito in poliuretano espanso indeformabile a densità differenziate e fibra poliestere rivestito in nabuk o velluto nei colori del campionario. Rete a doghe inclusa. Disponibile versione con comodini con luce integrata a LED in legno e metallo verniciati nero opaco dotati di cassetto con apertura rotante a 90°. Luce LED attivata da un sensore a movimento.

! Giroletto sfoderabile, non fissato alla testata.

La testata deve essere fissata al muro con staffe e ganci regolabili forniti in dotazione. Il fissaggio a parete possibile solo ed esclusivamente in presenza di muri di mattone forato o calcestruzzo. Non possibile in caso di muri di cartongesso.

Per la realizzazione di elementi con rivestimento in pelle sono necessarie cuciture aggiuntive rispetto gli elementi con rivestimento in tessuto.

Il legno è un materiale vivo che subisce un naturale processo di ossidazione che può causare cambiamenti cromatici. Venature e tonalità di colore differenti delle lastre non sono da considerarsi come difetti, ma caratteristiche che esaltano l'unicità del materiale.

NOTE TECNICHE SUI MATERIALI

INTARSIO | L'intarsio è una tecnica di lavorazione artigianale utilizzata per ottenere un particolare disegno e si realizza accostando elementi di materiali differenti (come legno e alluminio) oppure dello stesso materiale. Questa lavorazione rende il prodotto unico ed esclusivo. Le eventuali variazioni cromatiche e di venatura del legno sono da considerarsi caratteristiche del materiale stesso e non possono essere controllate.

Bed with boiserie headboard in "Colore" Frisé walnut herringbone wood inlay with adjustable side panels. Bedframe in non-deformable foam polyurethan in different density and polyester fiber with removable cover in nabuk or velvet as per samples. Wooden slats included. Available version with matt black painted wooden and metal bedside tables with integrated Led light, equipped with drawer with 90° rotating opening. Led light turned on by a motion sensor.

! Bed frame, not fixed to the headboard, with removable cover.

The headboard is fastened to the wall through provided adjustable wall brackets and hooks. The fixing against the wall is possible only with solid walls. It is not possible with plasterboards.

Additional stitching is required for elements with leather upholstery compared to elements with fabric upholstery.

Wood is a living material and the natural oxidation process can cause chromatic changes. Different grain and colour shades of the wooden slabs are not to be considered as defects, but characteristics that enhance the uniqueness of the material.

TECHNICAL INFORMATION ON THE MATERIALS

INLAY | Inlay is an artisanal technique used to obtain a particular design and is made by combining elements of different materials (such as wood and aluminium) or of the same material. This process makes the product unique and exclusive. Any colour and grain variations of the wood are to be considered as characteristics of the material itself and cannot be controlled.



Cm

300 x 211,5 x 141 (160 x 200)*

330 x 211,5 x 141 (180 x 200)*

360 x 211,5 x 141 (200 x 200)*

300 x 214,5 x 141 (153 x 203)*

360 x 214,5 x 141 (193 x 203)*

330 x 224,5 x 141 (183 x 213)*

* Materasso (L x P)

Inches

118 1/4" x 83 1/4" x 55 3/4" (63" x 78 3/4")*

130" x 83 1/4" x 55 3/4" (71" x 78 3/4")*

141 3/4" x 83 1/4" x 55 3/4" (78 3/4" x 78 3/4")*

118 1/4" x 84 1/2" x 55 3/4" (60 1/4" x 80")*

141 3/4" x 84 1/2" x 55 3/4" (76" x 80")*

130" x 88 1/2" x 55 3/4" (72 1/4" x 84")*

*Mattress (W x D)

[For technical drawing / p. 444](#)

Pricelist 2023 / p. 302
Homescapes, intimate portraits/ p. 65, 102
Homescapes, gentle attitude / pp. 52, 55

TESTATA/HEADBOARD



Legno noce "Colore" Frisé
"Colore" Frisé Walnut wood

RIVESTIMENTO/COVER



Nabuk/velluto nei colori
del campionario
Nabuk/velvet as per
samples.

COMODINI/BEDSIDE TABLE

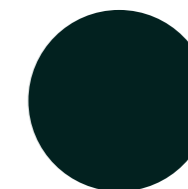

Legno e metallo verniciati
nero opaco
Matt black painted wooden
and metal

Lilas Bed

Dainelli Studio / 2022

Letto in poliuretano espanso indeformabile a densità differenziate e fibra poliestere con struttura interna in legno. Disponibile con rivestimento sfoderabile in tessuto o pelle nei colori del campionario. Rete a doghe inclusa.

Bed in non-deformable foam polyurethane in different density and polyester fibre with wooden inside structure. Available with removable cover in fabric or leather as per sample. Wooden slats included.

! Rivestimento sfoderabile.

Per la realizzazione di elementi con rivestimento in pelle sono necessarie cuciture aggiuntive rispetto gli elementi con rivestimento in tessuto.

! Removable cover for bed frame.

The headboard is fastened to the bed frame through a quick set and release coupling system.

Additional stitching is required for elements with leather upholstery compared to elements with fabric upholstery.



Cm

177 x 217 x 85 (160 x 200)*
197 x 217 x 85 (180 x 200)*
217 x 217 x 85 (200 x 200)*
177 x 217 x 85 (153 x 203)*
217 x 217 x 85 (193 x 203)*
197 x 227 x 85 (183 x 213)*

Cuscini a rullo

18 x 75 (160 x 200)*
18 x 85 (180 x 200)*
18 x 95 (200 x 200)*
18 x 71 (153 x 203)*
18 x 95 (193 x 203)*
18 x 86 (183 x 213)*

* Materasso (L x P)

Inches

69³/₄" x 85¹/₂" x 33¹/₂" (63" x 78³/₄")*
77³/₄" x 85¹/₂" x 33¹/₂" (71" x 78³/₄")*
85¹/₂" x 85¹/₂" x 33¹/₂" (78³/₄" x 78³/₄")*
69³/₄" x 85¹/₂" x 33¹/₂" (60¹/₄" x 80")*
85¹/₂" x 85¹/₂" x 33¹/₂" (76" x 80")*
77³/₄" x 89¹/₂" x 33¹/₂" (72¹/₄" x 84")*

Rollcushions

7¹/₄" x 29³/₄" (63" x 78³/₄")*
7¹/₄" x 33¹/₂" (71" x 78³/₄")*
7¹/₄" x 37¹/₂" (78³/₄" x 78³/₄")*
7¹/₄" x 28" (60¹/₄" x 80")*
7¹/₄" x 37¹/₂" (76" x 80")*
7¹/₄" x 34" (72¹/₄" x 84")*

*Mattress (W x D)

[For technical drawing / p. 445](#)

[Pricelist 2023 / p. 304](#)
[Homescapes, gentle attitude / pp. 98, 101](#)

RIVESTIMENTO/COVER



Tessuto/pelle nei colori del campionario
Fabric/leather as per samples.

Xeni

Massimo Castagna / 2018

Letto in poliuretano espanso indeformabile a densità differenziate e fibra poliestere con struttura interna in legno. Disponibile con rivestimento in tessuto o pelle nei colori di campionario. Rete a doghe inclusa.

Bed in non-deformable foam polyurethane in different density and polyester fibre with wooden inside structure. Available covered by fabric or leather as per sample. Wooden slats included.

! Giroletto sfoderabile.

La testata è fissata al giroletto tramite un pratico sistema di aggancio a baionetta.

Per la realizzazione di elementi con rivestimento in pelle sono necessarie cuciture aggiuntive rispetto gli elementi con rivestimento in tessuto.

! Removable cover for bed frame.

The headboard is fastened to the bed frame through a quick set and release coupling system.

Additional stitching is required for elements with leather upholstery compared to elements with fabric upholstery.



Cm

224 x 244 x 98 (160 x 200)*
244 x 244 x 98 (180 x 200)*
264 x 244 x 98 (200 x 200)*
217 x 247 x 98 (153 x 203)*
257 x 247 x 98 (193 x 203)*
247 x 257 x 98 (183 x 213)*

Inches

88 1/4" x 96 1/4" x 38 3/4" (63" x 78 3/4")*
96 1/4" x 96 1/4" x 38 3/4" (71" x 78 3/4")*
104" x 96 1/4" x 38 3/4" (78 3/4" x 78 3/4")*
85 1/2" x 97 1/4" x 38 3/4" (60 1/4" x 80")*
101 1/4" x 97 1/4" x 38 3/4" (76" x 80")*
97 1/4" x 101 1/4" x 38 3/4" (72 1/4" x 84")*

* Materasso (L x P)

* Mattress (W x D)

[For technical drawing / p. 445](#)

Pricelist 2023 / p. 306
Homescapes, sense of materials / p. 110
Homescapes, embracing beauty / p. 106

RIVESTIMENTO/COVER



Tessuto/pelle nei colori del campionario
Fabric/leather as per samples.

Yuki

Massimo Castagna / 2019

Letto imbottito in poliuretano espanso indeformabile a densità differenziate e fibra poliestere. Testata autoportante imbottita con pannelli laterali orientabili. Rete a doghe inclusa. Disponibile con rivestimento in tessuto o pelle nei colori di campionario. Dettagli in ottone satinato o laccato nero opaco. Su richiesta versione con prese USB (una per ogni lato).

Bed in non-deformable foam polyurethane in different density and polyester fibre. Freestanding upholstered headboard with adjustable side panels. Wooden slats included. Available covered by fabric or leather as per samples. Satin brass or opaque black lacquered brass details. USB charger ports version (one for each side) on request.

! Giroletto sfoderabile.

La testata è fissata al giroletto tramite un sistema di aggancio meccanico.

! Removable cover for bed frame.

The headboard is fastened to the bed frame through a mechanic system.

Per la realizzazione di elementi con rivestimento in pelle sono necessarie cuciture aggiuntive rispetto gli elementi con rivestimento in tessuto.

Additional stitching is required for elements with leather upholstery compared to elements with fabric upholstery.



Cm

343 x 225 x 135 (160 x 200)*
363 x 225 x 135 (180 x 200)*
393 x 225 x 135 (200 x 200)*
343 x 228 x 135 (153 x 203)*
393 x 228 x 135 (193 x 203)*
363 x 238 x 135 (183 x 213)*

Inches

135 3/4" x 88 3/4" x 53 1/4" (63" x 78 3/4")*
143" x 88 3/4" x 53 1/4" (71" x 78 3/4")*
154 3/4" x 88 3/4" x 53 1/4" (78 3/4" x 78 3/4")*
135 1/4" x 90" x 53 1/4" (60 1/4" x 80")*
154 3/4" x 90" x 53 1/4" (76" x 80")*
143" x 93 3/4" x 53 1/4" (72 1/4" x 84")*

* Materasso (L x P)

*Mattress (W x D)

[For technical drawing / p. 446](#)

[Pricelist 2023 / p. 308](#)

[Homescapes, sense of materials / p. 72](#)

[Homescapes, embracing beauty / p. 54](#)

[Homescapes, intimate portraits / p. 88, 93](#)

RIVESTIMENTO/COVER



Tessuto/pelle nei colori del campionario
Fabric/leather as per samples.

DETTAGLI/DETAILS



Ottone satinato
Satin brass

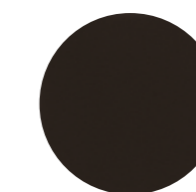

Laccato nero opaco
Matt black lacquered

**VERSIONE CON USB/
USB VERSION**



10

Letti / Beds
TECHNICAL MODULE

GENERAL INDICATION

■ tessuto/pelle consigliato
suggested fabric/leather
tissu/cuir conseillé
empfohlener Stoff/Leder

□ tessuto/pelle non utilizzabile
non-usable fabric/leather
tissu/cuir non utilisable
nicht verwendbarer Stoff/Leder

	CAT.A														CAT.B														CAT.C														CAT.D		CAT.L1		CAT.L2						
	Care	Chill	Cozy	Delight	Cape	Hope	Infinity	Joy	Sauvage	Velvet	Berlino	Daze	Deja	Clee	Glow	Harmony	Maze	Mingle	Path	Perky	Perseo	Sofi	Soul	Tokyo	Touch	Twist	Vision	Armonia	Bloom	Eden	Euphoria	Fluffy	Freedom	Futura	Utopia	Wonder	Alko	Pleasure	Zest	Fard	Suede	Leather	Nabuk										
Eve	□	□	□	□	□	□	□	□	□	■	□	□	□	□	□	□	□	□	□	□	□	□	□	□	□	□	□	□	□	□	□	□	□	□	□	□	□	□	□	□	□	□	□	□	□	■							
Lilas Bed	■	■	■	■	■	■	■	■	■	■	■	■	■	■	■	■	■	■	■	■	■	■	■	■	■	■	■	■	■	■	■	■	■	■	■	■	■	■	■	■	■	■	■	■	■	■	■	■	■	■			
Xeni	■	■	■	■	■	■	■	■	■	■	□	■	■	■	■	■	■	■	■	■	■	■	■	■	■	■	■	■	■	■	■	■	■	■	■	■	■	■	■	■	■	■	■	■	■	■	■	■	■	■	■		
Yuki	■	■	■	■	■	□	■	■	■	■	■	■	■	■	■	■	■	■	■	■	■	■	■	■	■	■	■	■	■	■	■	■	■	■	■	■	■	■	■	■	■	■	■	■	■	■	■	■	■	■	■	■	
cushions	■	■	■	■	■	■	■	■	■	■	■	■	■	■	■	■	■	■	■	■	■	■	■	■	■	■	■	■	■	■	■	■	■	■	■	■	■	■	■	■	■	■	■	■	■	■	■	■	■	■	■	■	■

Cuscini decorativi
Decorative cushions

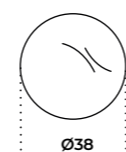

Ø38
Ø15"

Cuscino decorativo in fibra poliestere e chiusura con cerniera.

Decorative polyester fibre cushion with zip closure.

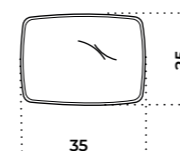

35 x 25
14" x 10"

Cuscino decorativo in fibra poliestere rifinito con bordo perimetrale e chiusura con cerniera.

Decorative polyester fibre cushion finished with perimetral trim and zip closure.

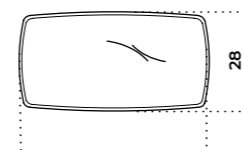

56 x 28
22 3/4" x 11 1/4"

Cuscino decorativo in fibra poliestere rifinito con bordo perimetrale e chiusura con cerniera.

Decorative polyester fibre cushion finished with perimetral trim and zip closure.

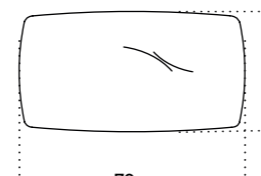

70 x 38
15 3/4" x 15"

Cuscino decorativo in fibra poliestere e chiusura con cerniera.

Decorative polyester fibre cushion with zip closure.

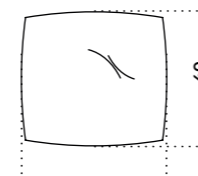

40 x 40
27 3/4" x 15 3/4"

Cuscino decorativo in fibra poliestere e chiusura con cerniera.

Decorative polyester fibre cushion with zip closure.

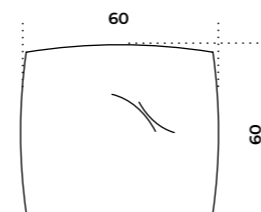

60 x 60
23 3/4" x 23 3/4"

Cuscino decorativo in fibra poliestere e chiusura con cerniera.

Decorative polyester fibre cushion with zip closure.

! Gallotti&Radice declina ogni responsabilità rispetto le prestazioni tecniche ed estetiche dei prodotti realizzati con tessuti/pelli non consigliate.

Gallotti&Radice declina ogni responsabilità rispetto alle prestazioni tecniche ed estetiche dei prodotti rivestiti con C.O.L. e C.O.M.

Per informazioni di dettaglio relative alla composizione, proprietà e lavaggio/manutenzione dei rivestimenti si rinvia al "Volume 4 | Materiali".

È possibile rivestire tutti i prodotti della collezione Gallotti&Radice con con tessuto/pelle cliente, previa approvazione di un campione. Gallotti&Radice non è responsabile per quanto riguarda il risultato formale, la durata del tessuto e la costanza dei colori (vedi: "Volume 4 | Materiali").

L'approvazione del tessuto fornito dal Cliente da parte di Gallotti&Radice si limita solamente alla realizzazione della tappezzeria.

Gallotti&Radice declina pertanto ogni responsabilità in merito alla resistenza all'uso, alla eventuale resistenza al fuoco o ad altre caratteristiche tecniche dei tessuti forniti dal Cliente.

Gallotti&Radice non è responsabile dei materiali inviati dal cliente, di eventuali difetti e carenze tecniche degli stessi, delle possibili reazioni difettose a prodotto tappezzato nonché delle istruzioni riguardanti manutenzione e lavaggio.

! Gallotti & Radice declines all responsibility for the technical and aesthetical performances of products made with non-recommended fabrics / leathers.

Gallotti & Radice declines all responsibility for technical and aesthetic performance of products covered with C.O.L. and C.O.M.

For detailed information on the composition, properties and maintenance of the upholstery, please refer to the "Volume 4 | Materials".

Furniture may be upholstered with customers' own fabrics after approval of a sample. Gallotti&Radice is not responsible for the aesthetic result, durability of the fabric and the uniformity of the colours (see: Volume 4 | Materials).

The approval by Gallotti&Radice of the C.O.L. and C.O.M is limited only to the upholstery. Gallotti&Radice therefore declines all responsibility for resistance to use, any resistance to fire or other technical characteristics of the fabrics supplied by the customer.

Gallotti & Radice is not responsible for the materials sent by the customer, for any defects and technical deficiencies of the same, for possible defective reactions to the upholstered product as well as for the instructions regarding maintenance and washing.

Eve | Pietro Russo, 2021

Product information / p. 432

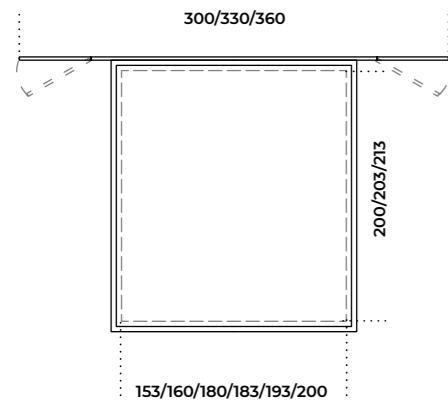
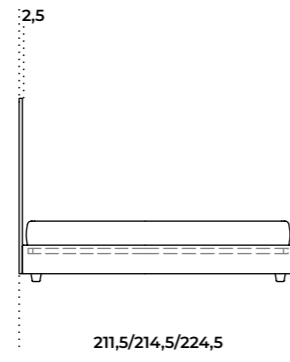
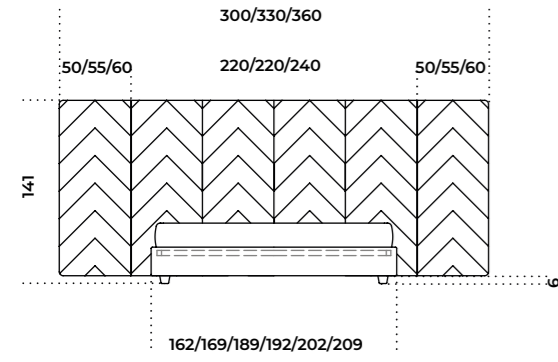

Versione con comodini
Bedside table version

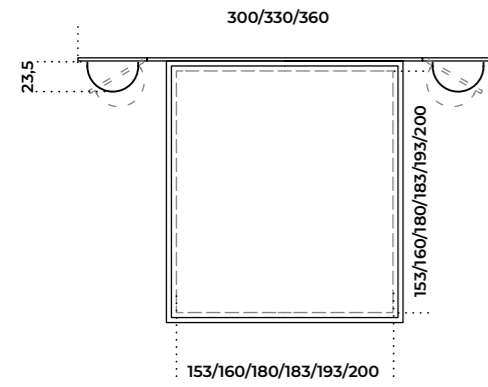
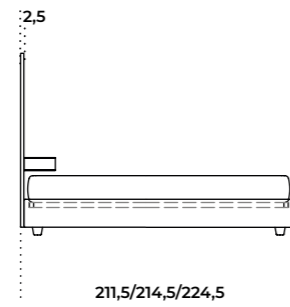
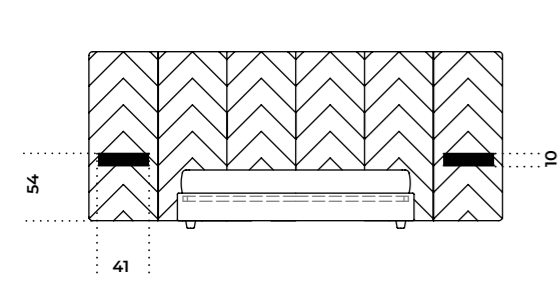

Lilas Bed | Dainelli Studio, 2022

Product information / p. 434

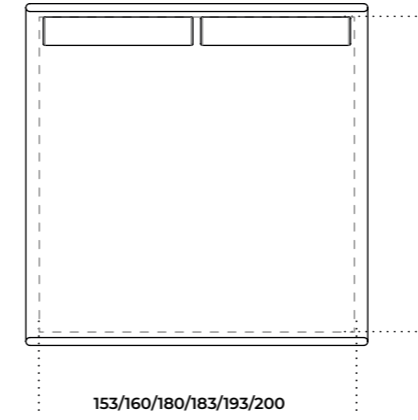
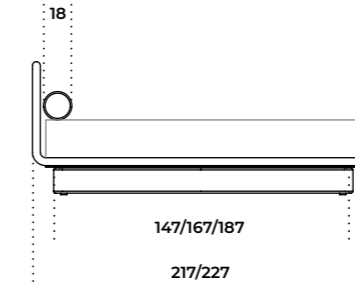
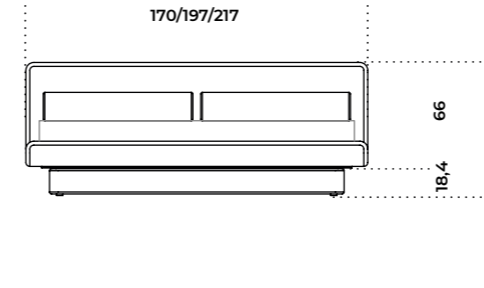

Xeni | Massimo Castagna, 2018

Product information / p. 436

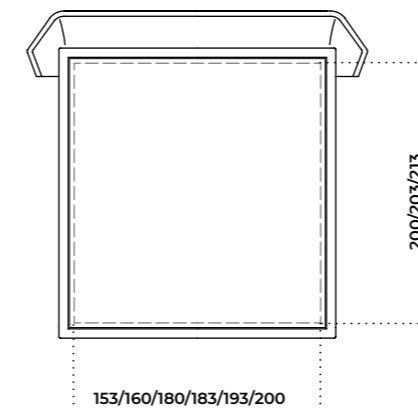
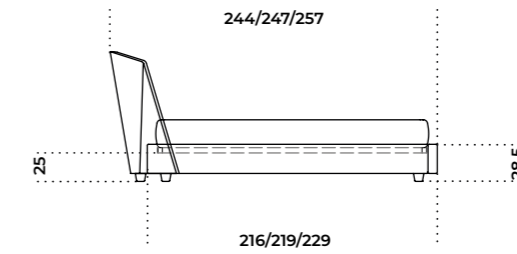
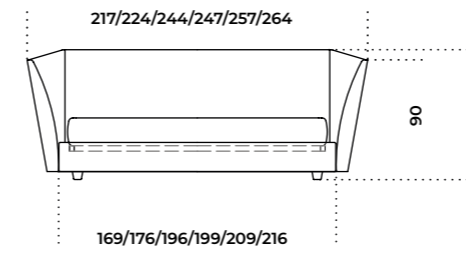

Fronte
Front

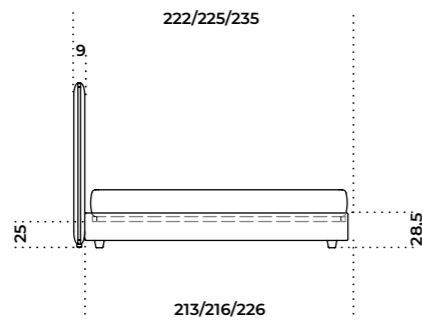
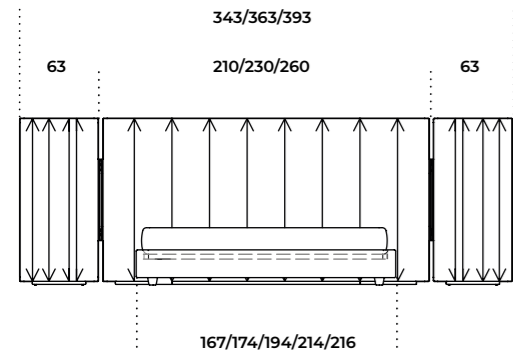

Retro
Back

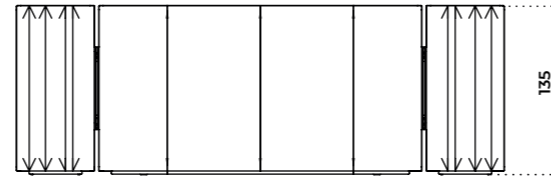

Versione senza prese USB
Version without USB socket

Fronte
Front

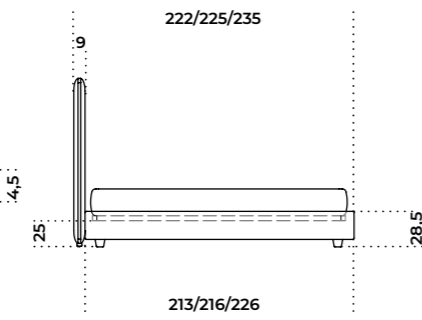
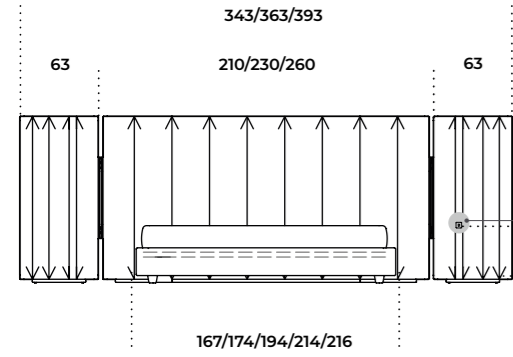

Retro
Back

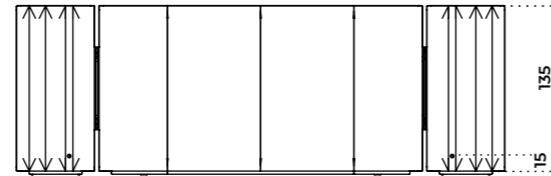

Versione con prese USB
Version with USB socket

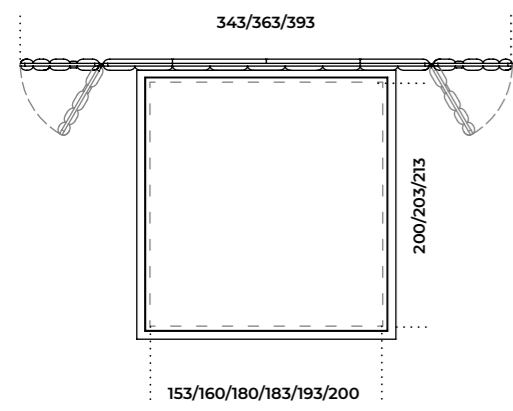

11 Complementi notte / Night accessories

- [450](#) [Duale](#)
- [452](#) [Holly Comò](#)
- [454](#) [Holly Comodino](#)
- [456](#) [Kumi Comò](#)
- [458](#) [Stami Night](#)
- [460](#) [Twelve C](#)

- [462](#) [Informazioni tecniche/
Technical informations](#)

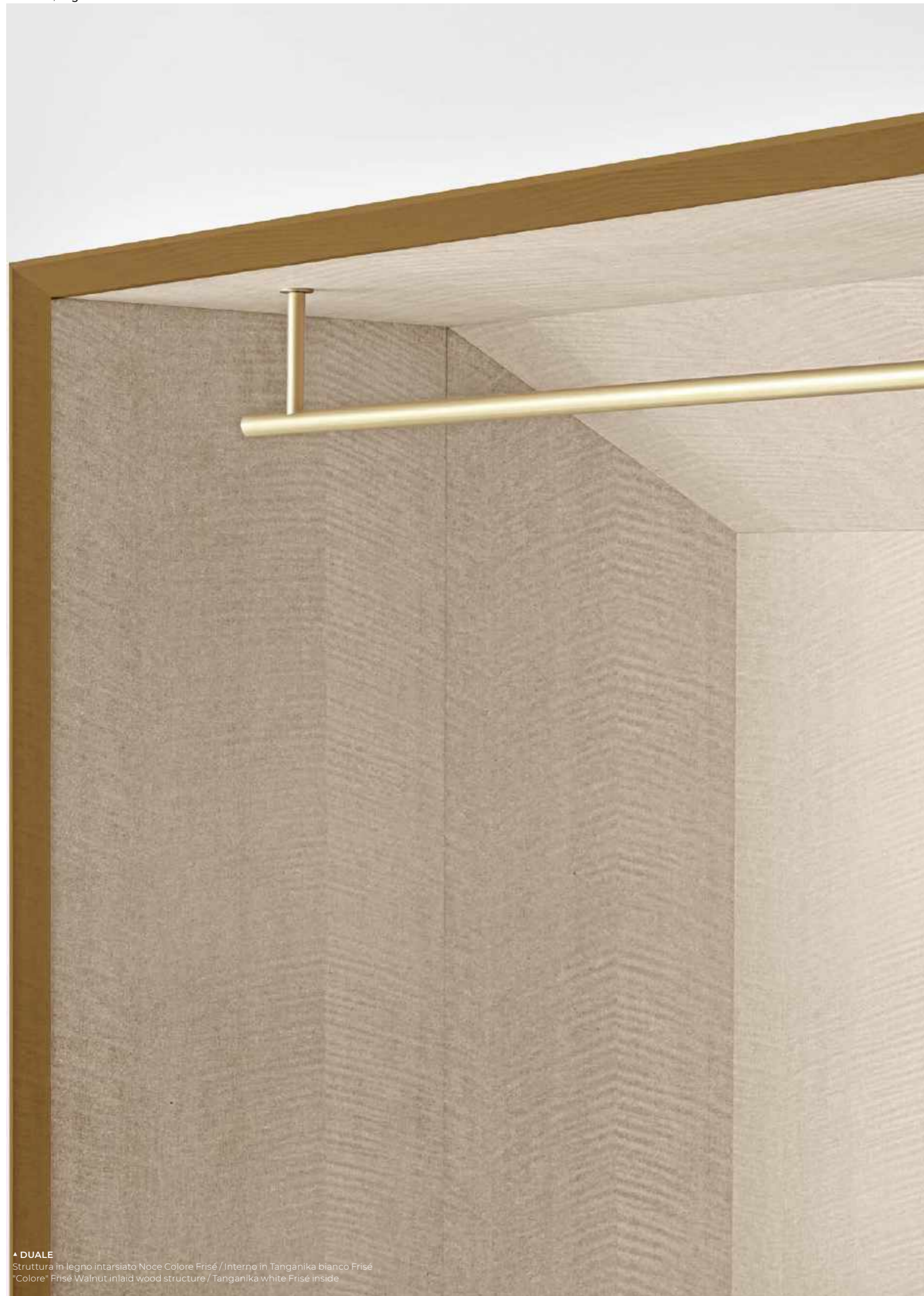

▲ **DUALE**
Struttura in legno intarsiato Noce "Colore" Frisé / Interno in Tanganika bianco Frisé
"Colore" Frisé Walnut inlaid wood structure / Tanganika white Frisé inside

Duale

Pietro Russo / 2019

Guardaroba a giorno in legno intarsiato Noce Colore Frisé. Interni rivestiti in Tanganika bianco Frisé. Accessoriato con appendiabiti e ripiano in legno (A) oppure a più ripiani (B).

! Il legno è un materiale vivo che subisce un naturale processo di ossidazione che può causare cambiamenti cromatici. Venature e tonalità di colore differenti delle lastre non sono da considerarsi come difetti, ma caratteristiche che esaltano l'unicità del materiale.

NOTE TECNICHE SUI MATERIALI

INTARSIO | L'intarsio è una tecnica di lavorazione artigianale utilizzata per ottenere un particolare disegno e si realizza accostando elementi di materiali differenti (come legno e alluminio) oppure dello stesso materiale. Questa lavorazione rende il prodotto unico ed esclusivo. Le eventuali variazioni cromatiche e di venatura del legno sono da considerarsi caratteristiche del materiale stesso e non possono essere controllate.

Wardrobe in "Colore" Frisé Walnut inlaid wood. Inside covered by Tanganika white Frisé wood. Supplied with one clothes rail and wooden shelf (A) or wooden multiple shelves (B).

! Wood is a living material and the natural oxidation process can cause chromatic changes. Different grain and colour shades of the wooden slabs are not to be considered as defects, but characteristics that enhance the uniqueness of the material.

TECHNICAL INFORMATION ON THE MATERIALS

INLAY | Inlay is an artisanal technique used to obtain a particular design and is made by combining elements of different materials (such as wood and aluminium) or of the same material. This process makes the product unique and exclusive. Any colour and grain variations of the wood are to be considered as characteristics of the material itself and cannot be controlled.



	Cm	Inches
A	100 x 57 x 180	39½" x 22½" x 71"
B	100 x 57 x 180	39½" x 22½" x 71"

For technical drawing / p. 464

Pricelist 2023 / p. 296
Homescapes, sense of materials / p. 81

STRUTTURA/STRUCTURE

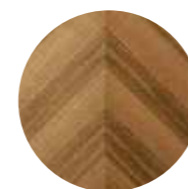

Legno intarsiato
Noce "Colore" Frisé
"Colore" Frisé Walnut
inlaid wood

INTERNO/INSIDE



Tanganika bianco Frisé
Tanganika white Frisé

DETTAGLI/DETAILS



Ottone satinato
Satin brass



Holly Comò

Pinuccio Borgonovo / 2020

Comò con due cassetti grandi, un cassetto piccolo, vano a giorno e piano estraibile con inserto in velluto disponibile nei colori del campionario. Cassetti montati su guide a estrazione totale. Struttura e piano estraibile in frassino tinto nero poro aperto oppure tinto grigio smoke poro aperto. Piano superiore e fianchi in cristallo temperato "grigio Italia" oppure cristallo extralight 10mm. Parti metalliche in alluminio spazzolato anodizzato nero. Su richiesta vassoio porta oggetti da inserire all'interno dei cassetti, realizzato in legno grigio con fondo rivestito in velluto disponibile nei colori del campionario.

Chest of drawers with two big drawers, one small drawer, open module and pull-out tray with velvet pad available as per samples. Drawers with total extraction runners. Structure and pull-out tray in either black open pore stained ash or grey smoke open pore stained ash. 10mm smoked "grigio Italia" or extralight glass top and sides. Metal parts in brushed black anodized aluminium. Grey wooden accessories tray with velvet bottom to be placed inside the drawers on request. Velvet finishes as per samples.



Cm
130 x 52 x 74
155 x 52 x 74

Inches
51¼" x 20½" x 29¼"
61¼" x 20½" x 29¼"

For technical drawing / p. 464

Pricelist 2023 / p. 297
Homescapes, embracing beauty / p. 55
Homescapes, gentle attitude / pp. 98, 99, 103

STRUTTURA/STRUCTURE

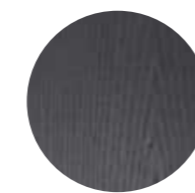

Frassino tinto
nero poro aperto
Black open pore
stained ash



Frassino tinto
grigio smoke
Grey Smoke open pore
stained ash

INSERTO PIANO ESTRAIBILE E FONDO VASSOIO PORTA OGGETTI/ PULL OUT TRAY PAD AND ACCESSORIES TRAY BOTTOM



Velluto nei colori del
campionario
Velvet as per samples.

TOP E SPALLE/ TOP AND SIDES



Cristallo fumè
"grigio Italia"
"Grigio Italia" smoked glass



Cristallo extralight
Extralight glass

PARTI METALLICHE/ METAL PARTS



Alluminio spazzolato
anodizzato nero
Black brushed aluminium

▲ HOLLY COMÒ

Struttura e cassetti in frassino tinto nero poro aperto / Piano e spalle in cristallo fumè "grigio Italia" / Inserti in Velvet peacock 705
Black open pore lacquered ash structure and drawers / Top and sides in smoked "grigio Italia" / Inserts cover in Velvet peacock 705



▲ HOLLY COMODINO

Struttura in frassino tinto nero poro aperto / Piano e fianchi in cristallo fumè "grigio talia" / Piano superiore del cassetto in frassino tinto nero poro aperto
Black open pore lacquered ash structure / Top and sides in smoked "grigio Italia" / Upper shelf of the drawer in black open pore lacquered ash

Holly Comodino

Pinuccio Borgonovo / 2020

Comodino con un cassetto. Struttura in frassino tinto nero poro aperto oppure tinto grigio smoke poro aperto. Cassetto montato su guide a estrazione totale. Piano superiore e fianchi in cristallo temperato "grigio Italia" oppure cristallo extralight 10mm. Parti metalliche in alluminio spazzolato anodizzato nero. Dotato di piano superiore del cassetto in frassino tinto nero poro aperto oppure tinto grigio smoke poro aperto come la struttura. Su richiesta disponibile in cristallo temperato decorato Craquelé oppure verniciato nella finitura esclusiva spazzolata "Cashmere" nei colori gold grey o anthracite.

NOTE TECNICHE SUI MATERIALI

CRISTALLO | Le finiture esclusive, risultato della lavorazione manuale realizzata sul cristallo, possono presentare striature e differenze cromatiche. Queste caratteristiche non devono essere considerate difetti ma elementi distintivi del processo artigianale che esaltano la bellezza e la peculiarità del pezzo unico.

Bedside table with one drawer. Structure in black open pore stained ash or grey smoke open pore stained ash. Drawer with total extraction runners. 10mm smoked "grigio Italia" or extralight glass tempered top and sides. Metal parts in brushed black anodized aluminium. Upper top of the drawer in black open pore stained ash or grey smoke open pore stained ash like the structure. Alternatively available in either tempered Craquelé glass or tempered painted with the exclusive "Cashmere" brushed glass finish in the gold grey or anthracite on request.

TECHNICAL INFORMATION ON THE MATERIALS

GLASS | Exclusive finishes, resulting from the craftsmanship on the glass, may show streaks and chromatic differences. These characteristics should not be considered imperfections but distinctive evidence of the hand-made process that enhance the beauty and peculiarity of the unique piece.



Cm

50 x 48 x 47
80 x 48 x 47

Inches

19¾" x 19" x 18¾"
31½" x 19" x 18¾"

[For technical drawing / p. 464](#)

[Pricelist 2023 / p. 298](#)
[Homescapes, embracing beauty / p. 54](#)

STRUTTURA/STRUCTURE

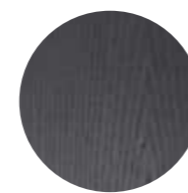

Frassino tinto
nero poro aperto
Black open pore
stained ash

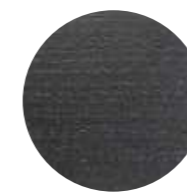

Frassino tinto
grigio smoke
Grey Smoke open pore
stained ash

TOP E SPALLE/ TOP AND SIDES



Cristallo "grigio Italia"
"Grigio Italia" smoked glass



Cristallo extralight
extralight glass

PIANO SUPERIORE CASSETTO/ UPPER SHELF OF THE DRAWER



Cristallo Craquelé
Craquelé glass

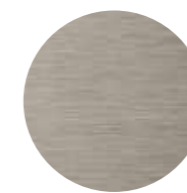

Cristallo spazzolato
"Cashmere" gold grey
"Cashmere" gold grey
brushed glass

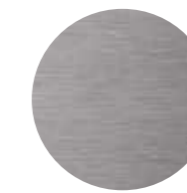

Cristallo spazzolato
"Cashmere" anthracite
"Cashmere" anthracite
brushed glass

PARTI METALLICHE/ METAL PARTS



Alluminio spazzolato
anodizzato nero
Black brushed aluminium



▲ KUMI COMÒ
Piano in marmo bisellato Verde Alpi / Struttura in tiglio tinto nero poro aperto e fascia zigrinata a mano
Verde Alpi bevelled marble top / Black lacquered open pore limnewood and hand knurled border

Kumi Comò

Carlo Colombo / 2020

Mobile notte con ante e cassetti. Struttura in legno tinto nero poro aperto, rivestita frontalmente e lateralmente con fascia zigrinata a mano. Ante laterali dotate di ripiano in legno. Piano disponibile in marmo bisellato lucido naturale Calacatta Vagli Oro, Verde Alpi, Arabescato Orobico Rosso satinato oppure cristallo temperato 6mm retroverniciato nero brillante. Maniglie e parti metalliche in metallo laccato color fango

NOTE TECNICHE SUI MATERIALI

MARMO | Il marmo è un materiale naturale di origine sedimentaria che può presentare particolarità come venature, lievi irregolarità superficiali, colorazioni differenti e cristallizzazioni. Queste peculiarità sono da attribuirsi alla naturalezza del materiale e non sono da considerarsi difetti ma caratteristiche tipiche del marmo. Ogni prodotto risulterà unico, esclusivo e non replicabile. I nostri marmi vengono trattati con un prodotto idrorepellente che permette una maggiore protezione della superficie stessa, aumentando l'impermeabilità. Questo trattamento non esclude la vulnerabilità del marmo alle sostanze acide.

Night unit with doors and drawers. Structure in black open pore stained wood. Fronts and sides clad with hand-knurled border. Lateral doors supplied with inside wooden shelf. Top available in bevelled natural polished Calacatta Vagli Oro, Verde Alpi, satin Arabescato Orobico Rosso marble or 6mm tempered bright black painted glass. Handles and metal parts lacquered in the "fango" colour.

TECHNICAL INFORMATION ON THE MATERIALS

MARBLE | The marble is a natural material of sedimentary origin that can present particularities such as veins, slight surface irregularities, different colors and crystallizations. These peculiarities are to be attributed to the naturalness of the material and are not to be considered defects but typical characteristics of marble. Each product will be unique, exclusive and non-replicable. Our marbles are treated with water-repellent products which affords greater protection to the surface of the marble, improving its impermeability. This treatment doesn't exclude the vulnerability of the marble to acid substances.



Cm

143 x 50 x 75
194 x 50 x 75

Inches

56½" x 19¾" x 29¾"
76½" x 19¾" x 29¾"

[For technical drawing / p. 465](#)

[Pricelist 2023 / p. 299](#)
[Homescapes, intimate portraits / p. 94, 97](#)
[Homescapes, gentle attitude / p. 61](#)

STRUTTURA/STRUCTURE

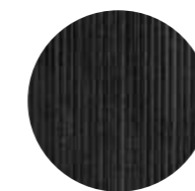

Legno tinto nero poro aperto
Black open pore stained wood

VERSIONE PIANO MARMO/MARBLE TOP VERSION



Marmo lucido naturale
Calacatta Vagli Oro
Natural polished
Calacatta Vagli Oro marble



Marmo lucido naturale
Verde Alpi
Natural polished
Verde Alpi marble



Marmo Arabescato
Orobico Rosso satinato
Arabescato Orobico
Rosso satin marble

VERSIONE PIANO CRISTALLO/ GLASS TOP VERSION

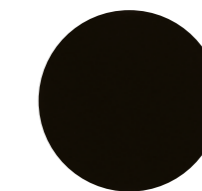

Cristallo retroverniciato
nero brillante
Bright black painted glass

PARTI METALLICHE/ METAL PARTS

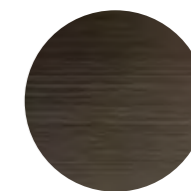

Metallo laccato "fango"
Metal lacquered "fango"



Stami Night

Studiopepe / 2023

Comodino con cassetto con base in frassino curvato tinto nero poro aperto e dettagli in ottone lucido. Struttura in legno con rivestimento in pelle o pelle scamosciata nei colori del campionario. Per la realizzazione di elementi con rivestimento in pelle sono necessarie cuciture aggiuntive.

Bedside with drawer with curved black open pore stained ash base and bright brass details. Wooden structure covered by leather or suede as per samples. Additional stitching is required for elements with leather upholstery.



Cm
69 x 45 x 49,5

Inches
27¼" x 17¾" x 19½"

[For technical drawing / p. 465](#)

[Pricelist 2023 / p. 300](#)

BASE/BASE



Frassino curvato tinto
nero poro aperto
Curved black open pore
stained ash

DETTAGLI/DETAILS

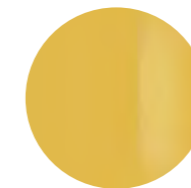

Ottone lucido
Bright brass

STRUTTURA/STRUCTURE



Legno rivestito in pelle o
pelle scamosciata
nei colori del campionario
Wooden structure covered
by leather or suede
as per samples.

▲ **TWELVE C**
Struttura in Frassino tinto nero poro aperto e ottone brunito a mano / Piano in cristallo Craquelé
Black open pore lacquered ash and hand burnished brass structure / Craquelé glass top

Twelve C

Massimo Castagna / 2018

Comodino in frassino tinto nero poro aperto. Piano in cristallo 6mm decorato a mano nella finitura Craquelé oppure retroverniciato liquirizia brillante. Struttura in ottone brunito a mano.

Black open pore stained ash night table. 6mm hand decorated Craquelé or bright liquorice painted glass top. Hand burnished brass structure.

NOTE TECNICHE SUI MATERIALI

OTTONE BRUNITO A MANO | L'ottone brunito a mano è ottenuto da un processo di ossidazione naturale eseguito manualmente. Il risultato di questa lavorazione è un prodotto che può presentare macchie e variazioni di colore che non sono da considerarsi imperfezioni ma caratteristiche che conferiscono ad ogni pezzo una particolare unicità, rendendolo esclusivo.

TECHNICAL INFORMATION ON THE MATERIALS

HAND BURNISHED BRASS | The hand burnished brass is the consequence of hand-made process of natural oxidation. The result of this processing is a product that may show marks and colour variations. These differences are inevitable and should not be considered imperfections but evidence of the hand-crafted process. They enhance the beauty and distinctiveness of a unique piece.

CRISTALLO | Le finiture esclusive, risultato della lavorazione manuale realizzata sul cristallo, possono presentare striature e differenze cromatiche. Queste caratteristiche non devono essere considerate difetti ma elementi distintivi del processo artigianale che esaltano la bellezza e la peculiarità del pezzo unico.

GLASS | Exclusive finishes, resulting from the craftsmanship on the glass, may show streaks and chromatic differences. These characteristics should not be considered imperfections but distinctive evidence of the hand-made process that enhance the beauty and peculiarity of the unique piece.



	Cm	Inches
A	40 x 40 x 49	15¾" x 15¾" x 19½"
B	40 x 40 x 54	15¾" x 15¾" x 21½"
C	80 x 40 x 49	31½" x 15¾" x 19½"

[For technical drawing / p. 466](#)

[Pricelist 2023 / p. 301](#)
[Homescapes, sense of materials / p. 112](#)
[Homescapes, embracing beauty / p. 107](#)
[Homescapes, intimate portraits / p. 89](#)

STRUTTURA/STRUCTURE



Frassino tinto nero poro aperto/
ottone brunito a mano
Black open pore
stained ash/
Hand burnished brass

PIANO/TOP



Cristallo Craquelé
Craquelé glass

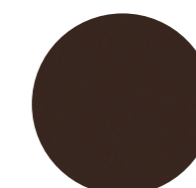

Cristallo retroverniciato
liquirizia brillante
Black bright liquorice
painted glass

▲ TWELVE C

Struttura in Frassino tinto nero poro aperto e ottone brunito a mano / Piano in cristallo Craquelé
Black open pore lacquered ash and hand burnished brass structure / Craquelé glass top

11

Complementi notte / Night accessories
TECHNICAL MODULE

Duale | Pietro Russo, 2019

Product information / p. 450

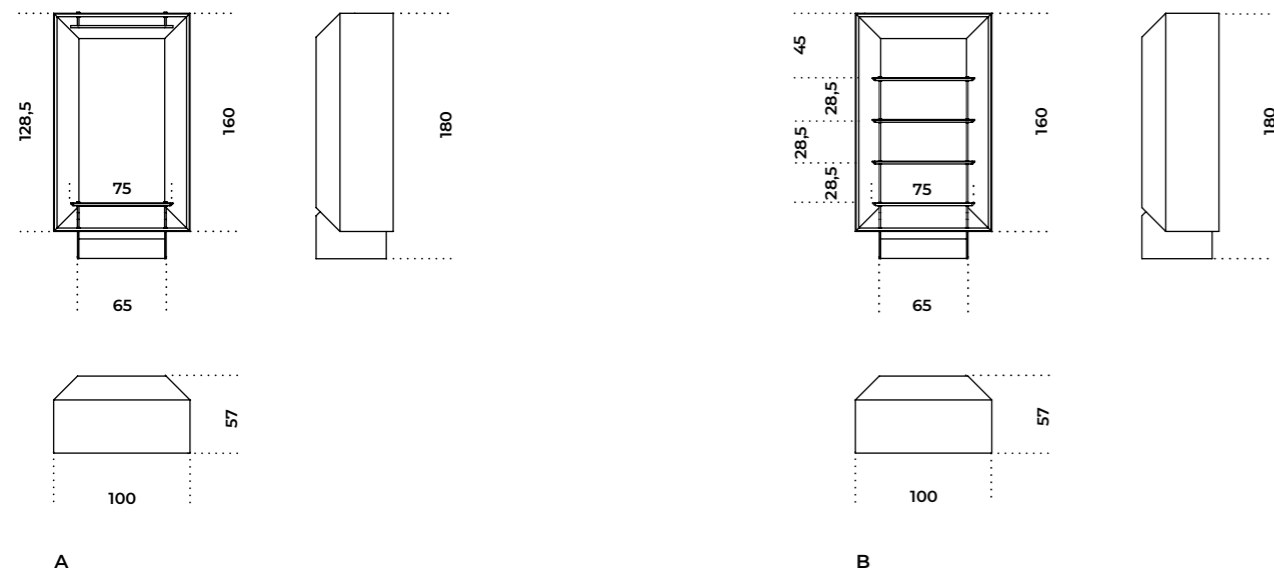

Kumi Comò | Carlo Colombo, 2020

Product information / p. 456

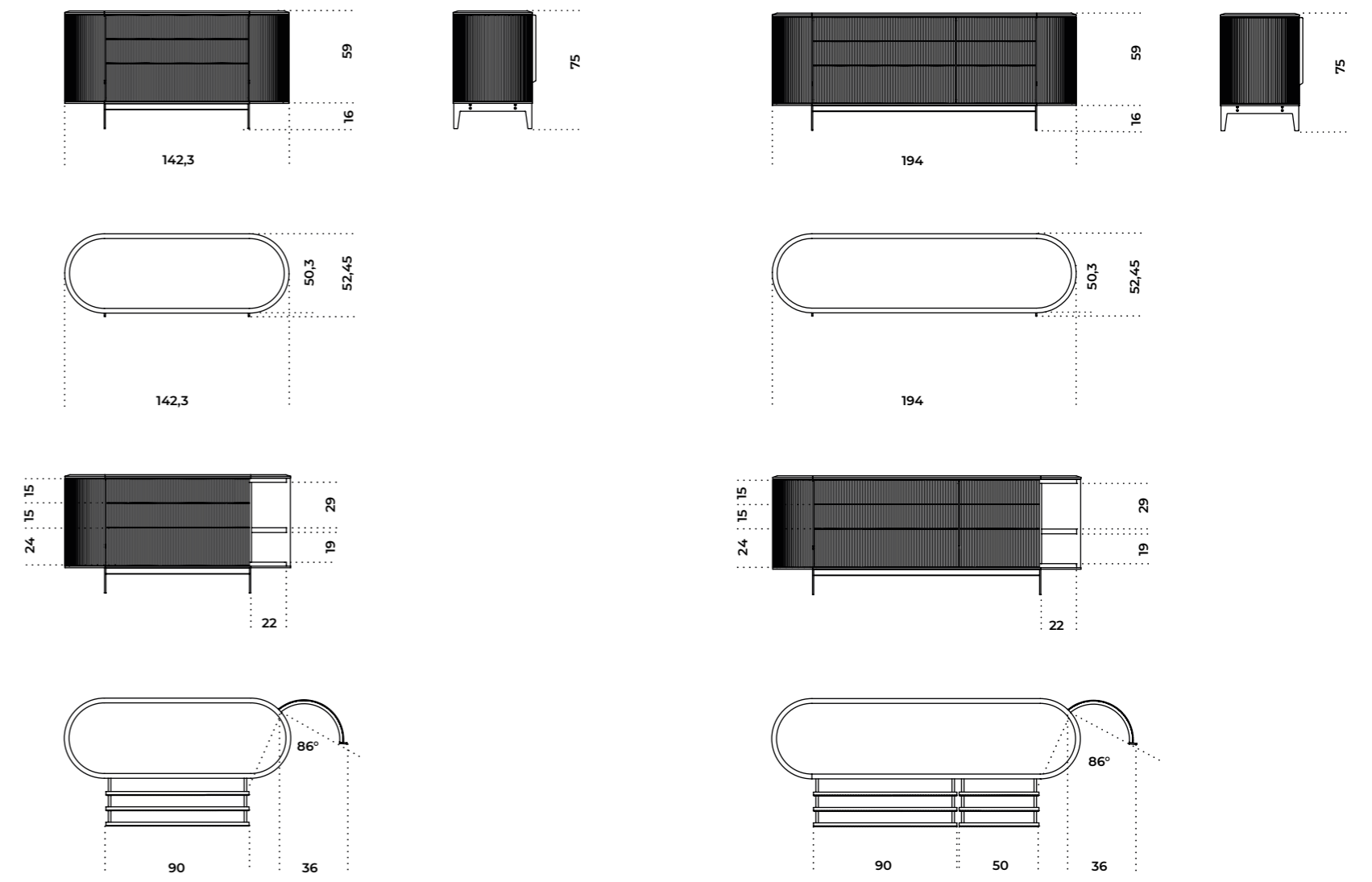

Holly Comò | Pinuccio Borgonovo, 2020

Product information / p. 452

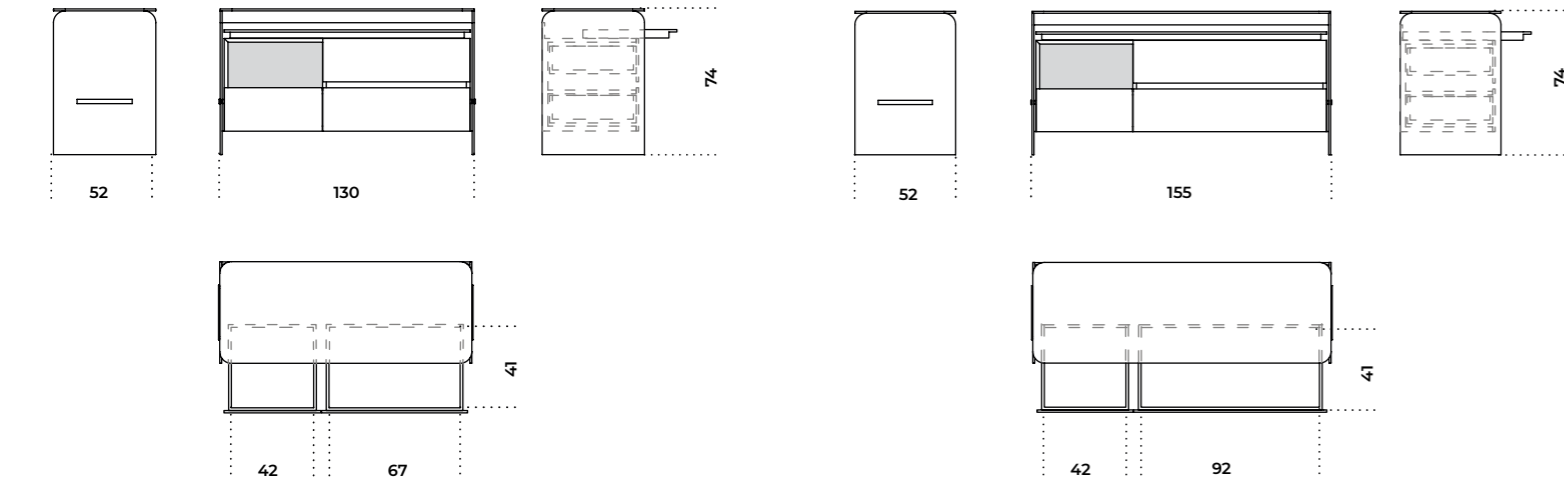

Holly Comodino | Pinuccio Borgonovo, 2020

Product information / p. 454

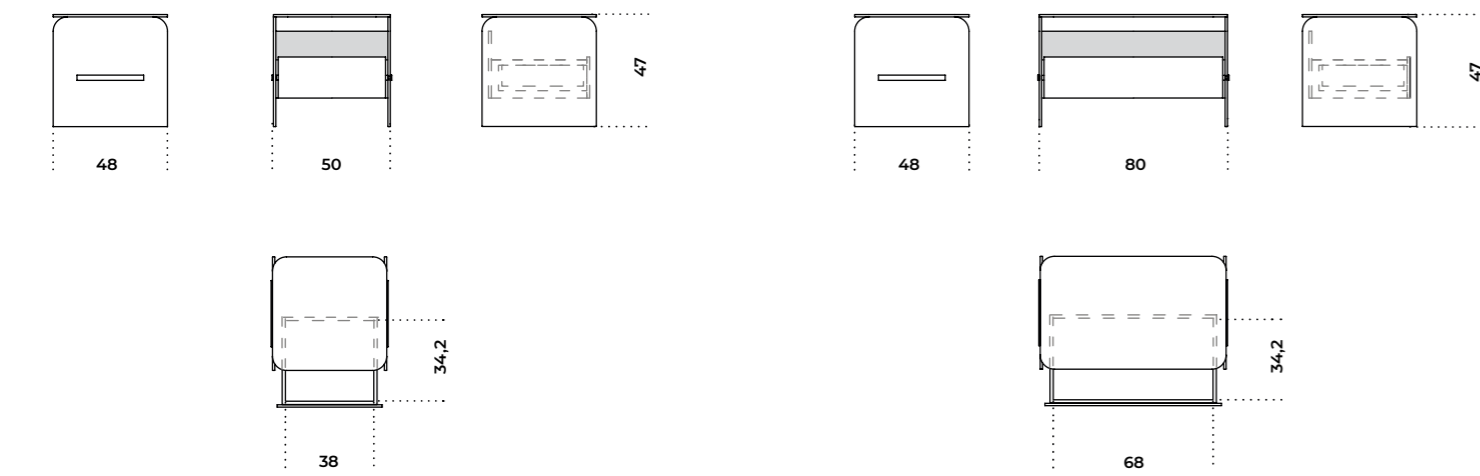

Stami Night | Studiopepe, 2023

Product information / p. 458

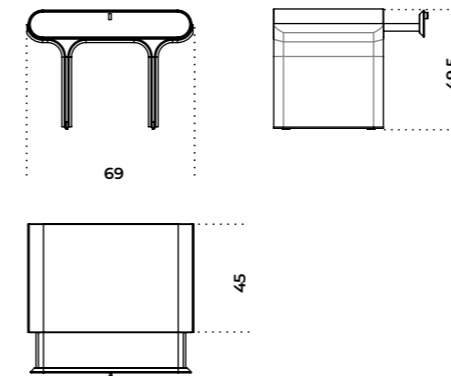

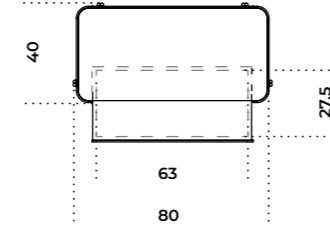
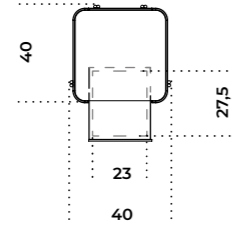
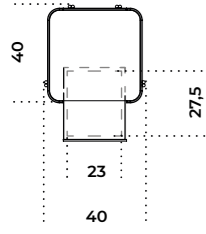
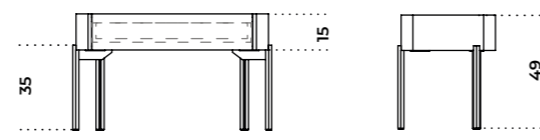
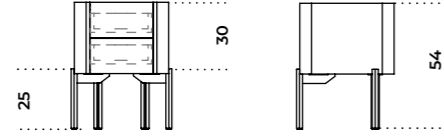
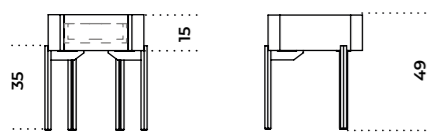

12 Scrittoi e Vanity / Desks and Vanity

- [470](#) [Lui](#)
- [472](#) [President Junior/President Senior](#)
- [474](#) [President Junior/President Senior 50th](#)
- [476](#) [Prism Desk](#)
- [478](#) [Selene](#)
- [480](#) [Soho](#)
- [482](#) [Stami](#)
- [484](#) [Tama Secrétaire](#)
- [486](#) [Venere](#)

- [488](#) [Informazioni tecniche/](#)
[Technical informations](#)



Lui

Paolo Maria Fumagalli / 2010

Scrivania con piano superiore in cristallo trasparente o extralight temperato 12mm con struttura in acciaio inox lucido o satinato. Disponibile anche in cristallo "grigio Italia" temperato 12mm con struttura in metallo laccato color brunito. Ripiano inferiore e cassetti in frassino naturale, tinto wengè, tinto tabacco, laccato bianco o laccato nero a poro aperto. Su richiesta tappetino in pelle scamosciata nei colori del campionario.

Desk with 12mm transparent or extralight tempered glass top with bright or satin stainless steel structure. Also available 12mm smoked "grigio Italia" tempered glass top with burnished lacquered metal structure. Natural ash, wengè stained, tobacco stained, lacquered white or lacquered black open pore bottom shelf and drawers. On request suede pad, available colours as per sample.

NOTE TECNICHE SUI MATERIALI

PELLE SCAMOSCIATA | Tutto il vissuto del manto resta completamente visibile e si manifesta in venature, graffi, possibili variazioni cromatiche, naturali arricciature, che conferiscono a questa pelle una preziosità unica.

TECHNICAL INFORMATION ON THE MATERIALS

SUEDE | The layer's past is fully visible and is expressed in the grain, possible colour variations, and natural crimping, which give this leather a unique precious feel.



Cm

140 x 65 x 75
160 x 65 x 75
180 x 65 x 75

Inches

55¼" x 25¾" x 29¾"
63" x 25¾" x 29¾"
71" x 25¾" x 29¾"

[For technical drawing / p. 490](#)

[Pricelist 2023 / p. 230](#)

PIANO SUPERIORE E STRUTTURA / TOP AND STRUCTURE



Cristallo trasparente/
Acciaio inox lucido
Transparent glass/
Bright stainless steel

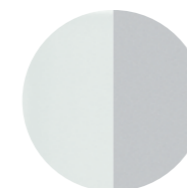

Cristallo trasparente/
Acciaio inox satinato
Transparent glass/
Satin stainless steel



Cristallo extralight/
Acciaio inox lucido
Extralight glass/
Bright stainless steel



Cristallo extralight/
Acciaio inox satinato
Extralight glass/
Satin stainless steel

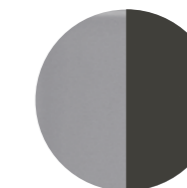

Cristallo "grigio Italia"/
Metallo laccato color brunito
"Grigio Italia" glass/
Burnished lacquered metal

PIANO INFERIORE E CASSETTI / BOTTOM SHELF AND DRAWERS



Frassino naturale
Natural ash



Frassino tinto wengè
Wengè stained ash

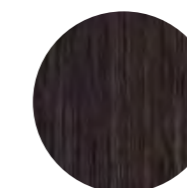

Frassino tinto tabacco
Tobacco stained ash

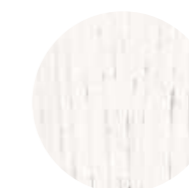

Frassino laccato
bianco poro aperto
White open pore
lacquered ash



Frassino laccato
nero poro aperto
Black open pore
lacquered ash

TAPPETINO/PAD



Pelle scamosciata
nei colori del campionario
Suede as per samples.



▲ **PRESIDENT SENIOR**
Struttura in cristallo trasparente temperato / Parti metalliche in acciaio inox lucido
Transparent tempered glass structure / Bright stainless steel metal parts

President Junior/President Senior

Studio G&R / 1971

Scrivania in cristallo trasparente, extralight o "grigio Italia" temperato 10mm (President Junior) o 12mm (President Senior).
Parti metalliche in acciaio inox lucido o satinato.
Disponibili anche in ottone lucido, ottone satinato o laccato bianco o nero gofrato.

Desk with 10mm (President Junior) or 12mm (President Senior) transparent, extralight or smoked "grigio Italia" tempered glass. Bright or satin stainless steel metal parts.
Also available bright brass, satin brass or embossed white or black lacquered metal parts.



Cm
President Junior
172 x 80 x 74

Inches
President Junior
67¾" x 31½" x 29¼"

President Senior
210 x 106 x 74

President Senior
82¾" x 41¾" x 29¼"

For technical drawing / p. 490

Pricelist 2023 / p. 231

Homescapes, embracing beauty / p. 41, 42-44

STRUTTURA/STRUCTURE



Cristallo trasparente
Transparent glass



Cristallo extralight
Extralight glass



Cristallo "grigio Italia"
Smoked "grigio Italia" glass

PARTI METALLICHE/ METAL PARTS

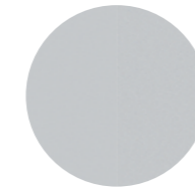

Acciaio inox lucido
Bright stainless steel



Acciaio inox satinato
Satin stainless steel

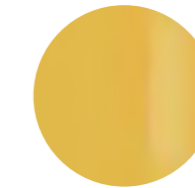

Ottone lucido
Bright brass



Ottone satinato
Satin brass



Laccato bianco gofrato
Embossed white lacquered



Laccato nero gofrato
Embossed black lacquered



▲ **PRESIDENT JUNIOR**
Struttura in cristallo extralight temperato "Crisscross gold" / Parti metalliche in "Crisscross gold"
"Crisscross gold extralight tempered glass structure / "Crisscross gold" metal parts

President Junior/President Senior^{50th Anniversary}

Studio G&R/Silvia Gallotti, 2021

Scrivania in cristallo extralight temperato 10mm (President Junior) o 12mm (President Senior) verniciato nella finitura esclusiva "crisscross gold". Parti metalliche verniciate nella finitura esclusiva "crisscross gold". Collezione in edizione numerata.

NOTE TECNICHE SUI MATERIALI

CRISTALLO | Le finiture esclusive, risultato della lavorazione manuale realizzata sul cristallo, possono presentare macchie e striature, oltre a differenze cromatiche. Tali disomogeneità sono caratteristiche che non devono essere considerate difetti ma elementi distintivi che esaltano la bellezza e la peculiarità del pezzo unico.

Desk with 10mm (President Junior) or 12mm (President Senior) extralight tempered glass decorated with the exclusive "crisscross gold" finish. Metal parts painted with the exclusive finish "crisscross gold". Collection in numbered edition.

TECHNICAL INFORMATION ON THE MATERIALS

GLASS | Artisanal and exclusive finishes that are obtained from the oxidation of silver, gold and copper leaves may show marks and spots, as well as variations in colour. These differences are inevitable and should not be considered imperfections but evidence of the hand-crafted process. They enhance the beauty and distinctiveness of a unique piece.



Cm
President Junior
172 x 80 x 74

President Senior
210 x 106 x 74

Inches
President Junior
67³/₄" x 31¹/₂" x 29¹/₄"

President Senior
82³/₄" x 41³/₄" x 29¹/₄"

[For technical drawing / p. 490](#)

[Pricelist 2023 / p. 232](#)
[Homescapes, intimate portraits / p. 33, 35-37](#)

PIANO E SPALLE/ TOP AND SIDES



Cristallo verniciato
"crisscross gold"
"Crisscross gold"
painted glass

PARTI METALLICHE/ METAL PARTS



Metallo verniciato
"crisscross gold"
"Crisscross gold"
painted metal



▲ **PRISM DESK**
Struttura in Palissandro India intarsiato con alluminio naturale
India Rosewood and natural aluminium structure

Prism Desk

David/Nicolas /2019

Scrivania in legno Noce Colore Frisé intarsiato con alluminio naturale o Palissandro India intarsiato con alluminio naturale. Basi dotate di due ripiani in cristallo extralight temperato 8 mm.

Wooden desk with marquetry of "Colore" Frisé Walnut and natural aluminium or India Rosewood and natural aluminium. Bases provided with two 8 mm thick extralight tempered internal shelves.

! Il legno è un materiale vivo che subisce un naturale processo di ossidazione che può causare cambiamenti cromatici. Venature e tonalità di colore differenti delle lastre non sono da considerarsi come difetti, ma caratteristiche che esaltano l'unicità del materiale.

! Wood is a living material and the natural oxidation process can cause chromatic changes. Different grain and colour shades of the wooden slabs are not to be considered as defects, but characteristics that enhance the uniqueness of the material.

NOTE TECNICHE SUI MATERIALI

INTARSIO | L'intarsio è una tecnica di lavorazione artigianale utilizzata per ottenere un particolare disegno e si realizza accostando elementi di materiali differenti (come legno e alluminio) oppure dello stesso materiale. Questa lavorazione rende il prodotto unico ed esclusivo. Le eventuali variazioni cromatiche e di venatura del legno sono da considerarsi caratteristiche del materiale stesso e non possono essere controllate.

TECHNICAL INFORMATION ON THE MATERIALS

INLAY | Inlay is an artisanal technique used to obtain a particular design and is made by combining elements of different materials (such as wood and aluminium) or of the same material. This process makes the product unique and exclusive. Any colour and grain variations of the wood are to be considered as characteristics of the material itself and cannot be controlled.



Cm
210 x 93,5 x 74
230 x 93,5 x 74

Inches
83¼" x 37" x 29¼"
90¾" x 37" x 29¼"

[For technical drawing / p. 491](#)

[Pricelist 2023 / p. 233](#)
[Homescapes, embracing beauty / p. 48](#)

STRUTTURA/STRUCTURE

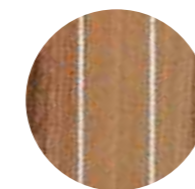

Legno Noce "Colore" Frisé e alluminio naturale
"Colore" Frisé Walnut and aluminium

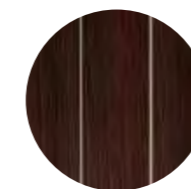

Legno palissandro India e alluminio naturale
India rosewood and aluminium

RIPIANI/INSIDE SHELVES



Cristallo extralight
Extralight glass

Selene

Pietro Russo / 2016

Scrittoio-vanity in Taba Frisé bianco e Tanganika nero. Cassetti laterali push-pull con apertura rotante a 90° e cassetto centrale con apertura frontale. Parti metalliche laccate ottone satinato. Specchio extralight in 6mm bisellato. Dotato di Luce LED. Parti metalliche laccate ottone satinato e base in marmo levigato opaco Nero Marquinia.

Vanity desk in Taba Frisé white wood and Tanganika black wood. Push-pull side drawers with 90° rotating opening and front opening central drawer. Satin brass lacquered metal parts. 6mm bevelled extralight mirror. With LED light. Satin brass lacquered metal parts and honed mat Nero Marquinia marble base.

! Nella versione senza specchio il piano viene fornito con ciotola in ottone satinato.

! In the version without mirror the wooden top is supplied with satin brass tray.

NOTE TECNICHE SUI MATERIALI

MARMO | Il marmo è un materiale naturale di origine sedimentaria che può presentare particolarità come venature, lievi irregolarità superficiali, colorazioni differenti e cristallizzazioni. Queste peculiarità sono da attribuirsi alla naturalezza del materiale e non sono da considerarsi difetti ma caratteristiche tipiche del marmo. Ogni prodotto risulterà unico, esclusivo e non replicabile.

INTARSIO | L'intarsio è una tecnica di lavorazione artigianale utilizzata per ottenere un particolare disegno e si realizza accostando elementi di materiali differenti (come legno e alluminio) oppure dello stesso materiale. Questa lavorazione rende il prodotto unico ed esclusivo. Le eventuali variazioni cromatiche e di venatura del legno sono da considerarsi caratteristiche del materiale stesso e non possono essere controllate.

TECHNICAL INFORMATION ON THE MATERIALS

MARBLE | The marble is a natural material of sedimentary origin that can present particularities such as veins, slight surface irregularities, different colors and crystallizations. These peculiarities are to be attributed to the naturalness of the material and are not to be considered defects but typical characteristics of marble. Each product will be unique, exclusive and non-replicable.

INLAY | Inlay is an artisanal technique used to obtain a particular design and is made by combining elements of different materials (such as wood and aluminium) or of the same material. This process makes the product unique and exclusive. Any colour and grain variations of the wood are to be considered as characteristics of the material itself and cannot be controlled.



Cm

Versione con specchio

130 x 50 x 143

Versione senza specchio

130 x 50 x 78

Inches

Version with mirror

51¼" x 19¾" x 56½"

Version without mirror

51¼" x 19¾" x 30¾"

[For technical drawing / p. 491](#)

[Pricelist 2023 / p. 234](#)
[Homescapes, embracing beauty / p. 53](#)

STRUTTURA/STRUCTURE

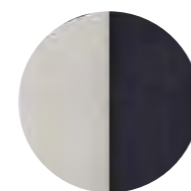

Taba Frisé bianco/
Tanganika nero
Taba Frisé white wood/
Tanganika black wood

PARTI METALLICHE/ METAL PARTS



Laccato ottone satinato
Satin brass lacquered
metal

SPECCHIO/MIRROR



Specchio extralight
Extralight mirror

PARTI METALLICHE SPECCHIO/MIRROR METAL PARTS

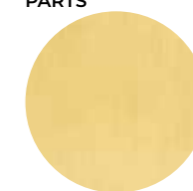

Ottone satinato
Satin brass

BASE SPECCHIO / MIRROR BASE



Marmo levigato opaco
Nero Marquinia
Honed mat
Nero Marquinia marble

LUCE/LIGHT

15 watt
108 lm/w
3000k



▲ SOHO
Struttura in frassino tinto nero poro aperto / Piano in marmo Calacatta Vagli Oro / Ottone lucido
Black open pore lacquered ash structure / Calacatta Vagli Oro marble top / Bright brass metal part

Soho

Carlo Colombo / 2017

Scrittoio in massello di frassino tinto nero poro aperto con fascia zigrinata realizzata a mano. Piano in marmo lucido naturale Calacatta Vagli Oro oppure in cristallo 12mm retroverniciato liquirizia nella versione brillante o satinata. Dotato di due cassetti ad estrazione totale, con fondo in pelle scamosciata Grey 020. Parti metalliche in ottone lucido. Su richiesta vaschette portaoggetti rivestite in pelle scamosciata grey 020.

! Il legno massello è molto sensibile alla luce, il posizionamento vicino a sorgenti di luce naturale ne compromette la colorazione e la stabilità. Un'elevata variazione della temperatura e umidità dell'aria può provocare la comparsa di microfratture e leggere variazioni.

NOTE TECNICHE SUI MATERIALI

MARMO | Il marmo è un materiale naturale di origine sedimentaria che può presentare particolarità come venature, lievi irregolarità superficiali, colorazioni differenti e cristallizzazioni. Queste peculiarità sono da attribuirsi alla naturalezza del materiale e non sono da considerarsi difetti ma caratteristiche tipiche del marmo. Ogni prodotto risulterà unico, esclusivo e non replicabile. I nostri marmi vengono trattati con un prodotto idrorepellente che permette una maggiore protezione della superficie stessa, aumentando l'impermeabilità. Questo trattamento non esclude la vulnerabilità del marmo alle sostanze acide.

Desk in black open pore stained solid ash with hand-knurled sides. Natural polished Calacatta Vagli Oro marble or 12mm liquorice painted glass top, in the bright or satin version. Supplied with two drawers with suede Grey 020 bottom. Bright brass metal parts. On request, small boxes covered by suede Grey 020.

! Solid wood is very light-sensitive, placing it near natural light sources may compromise its colour and stability. Considerable differences in air temperature and humidity may cause microfractures and slight variations.

TECHNICAL INFORMATION ON THE MATERIALS

MARBLE | The marble is a natural material of sedimentary origin that can present particularities such as veins, slight surface irregularities, different colors and crystallizations. These peculiarities are to be attributed to the naturalness of the material and are not to be considered defects but typical characteristics of marble. Each product will be unique, exclusive and non-replicable. Our marbles are treated with water-repellent products which affords greater protection to the surface of the marble, improving its impermeability. This treatment doesn't exclude the vulnerability of the marble to acid substances.

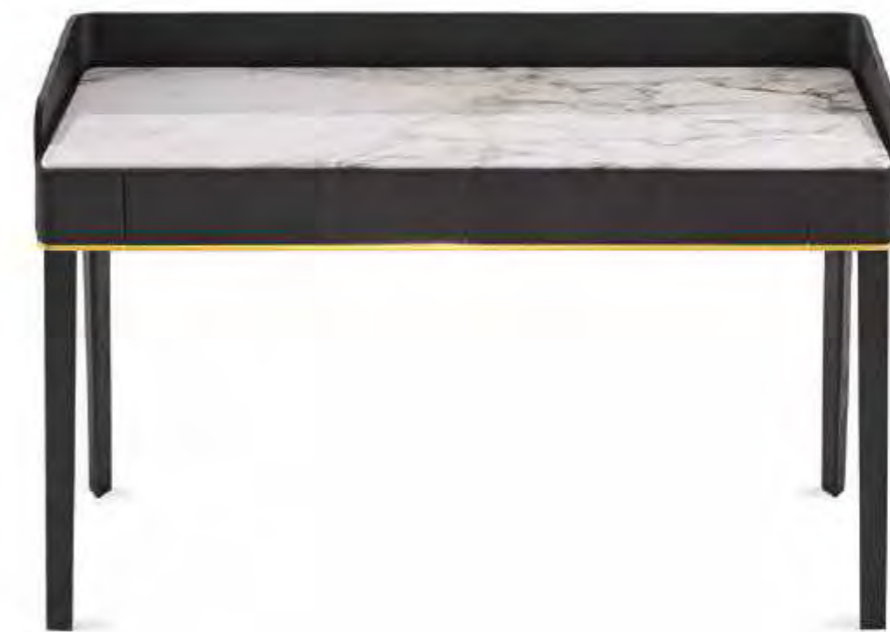

Cm
130 x 55 x 84
Vaschette portaoggetti
13 x 13 x 4

Inches
51¼" x 21¾" x 33¼"
Small boxes
5¼" x 5¼" x 1¼"

[For technical drawing / p. 491](#)

[Pricelist 2023 / p. 235](#)
[Homescapes, intimate portraits/ p. 99](#)

STRUTTURA/STRUCTURE PIANO/TOP

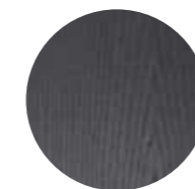

Frassino tinto
nero poro aperto
Black open pore
stained ash



Marmo lucido naturale
Calacatta Vagli Oro
Natural polished
Calacatta Vagli Oro marble

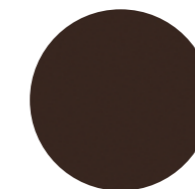

Cristallo retroverniciato
liquirizia brillante/satinato
Bright/satin liquorice
painted glass

FONDO CASSETTI/ DRAWERS BOTTOM



Pelle scamosciata Grey 020
Suede Grey 020

PARTI METALLICHE/ METAL PARTS

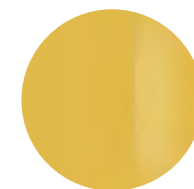

Ottone lucido
Bright brass

Stami

Studiopepe/2022

Desk e vanity con base in frassino curvato tinto nero poro aperto e dettagli in ottone lucido. Struttura in legno con rivestimento in pelle o pelle scamosciata nei colori del campionario. Piano apribile a ribalta in legno tinto nero poro aperto e vano interno dotato di sottomano in pelle o pelle scamosciata coordinata con il rivestimento esterno. Piano a ribalta con lavagna magnetica (desk) o con specchio (vanity). Disponibile anche versione con cassetti laterali.

Desk and vanity desk with curved black open pore stained ash base and bright brass details. Wooden structure covered by leather or suede as per samples. Black open pore stained wooden opening top and internal compartment equipped with leather or suede pad coordinated with the external upholstery. Opening top with magnetic board (desk) or with mirror (vanity). Also available version with side drawers.

! Per la realizzazione di elementi con rivestimento in pelle sono necessarie cuciture aggiuntive rispetto gli elementi con rivestimento in tessuto.

! Additional stitching is required for elements with leather upholstery compared to elements with fabric upholstery.



Cm
Scrivania
140 x 60 x 76
Vanity
140 x 60 x 76

Porta-oggetti per vanity desk
65 x 34 x 2

Inches
Desk
55 1/4" x 23 3/4" x 30"
Vanity
55 1/4" x 23 3/4" x 30"

Organiser for vanity desk
25 3/4" x 13 1/2" x 1"

[For technical drawing / p. 492](#)

[Pricelist 2023 / p. 236](#)
[Homescapes, intimate portraits / p. 99](#)
[Homescapes, gentle attitude / pp. 54, 57](#)

**RIVESTIMENTO ESTERNO/
EXTERNAL UPHOLSTERY**



**Pelle/pelle scamosciata
nei colori del campionario**
Leather/suede as per
samples.

BASE/BASE

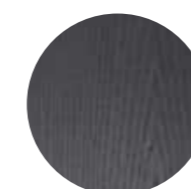

**Frassino curvato
tinto nero poro aperto**
Curved black open pore
stained ash

DETTAGLI/ DETAILS



Ottone lucido
Bright brass

**PIANO APRIBILE
E VANO INTERNO/
OPENING TOP
AND INTERNAL COMPARTMENT**



Legno tinto nero poro aperto
Black open pore stained wood

**SOTTOMANO/
WRITING PAD**



**Pelle/pelle scamosciata
nei colori del campionario**
Leather/suede as per
samples.

▲ **STAMI**
Base in frassino curvato tinto nero poro aperto / Struttura rivestito in suede grey 058
Curved black open pore lacquered ash base / Covered by suede grey 058 structure



▲ TAMA SECRÉTAIRE
Struttura in frassino tinto nero poro aperto / Parti metalliche in ottone lucido / Top in cristallo retroverniciato liquirizia brillante
Black open pore lacquered ash structure / Bright brass metal parts / Bright liquorice painted glass top

Tama Secrétaire

Carlo Colombo / 2016

Scrittoio a ribalta in frassino tinto nero poro aperto. Parti metalliche laccate ottone satinato. Top e schienale interno in cristallo 6mm retroverniciato liquirizia brillante. Lo schienale riporta incisione "a rombi". Interno ribalta e scatole portaoggetti rivestiti in pelle scamosciata Grey 058. Dotata di luce interna LED attivata da un sensore all'apertura dell'anta. Cavo elettrico lungo 1,5 mt.

Writing desk with flap door in black open pore stained ash. Satin brass lacquered metal parts. 6mm bright liquorice painted glass top and inside back. Rhomboidal engraved pattern on the inside glass back. Inside part of flap door and small boxes covered by suede Grey 058. Supplied with inside LED light turned on by sensor as door is opened. 1,5 mt long electric cable.



Cm
120 x 36 x 110
140 x 36 x 110

Inches
47¼" x 14¼" x 43½"
55¼" x 14¼" x 43½"

For technical drawing / p. 492

Pricelist 2023 / p. 237

STRUTTURA/STRUCTURE

PARTI METALLICHE

PIANO/TOP

SCHIENALE INTERNO/
INSIDE BACK

INTERNO RIBALTA E
PORTAOGGETTI/ INSIDE
FLAP DOOR AND BOXES

LUCE INTERNA/
INSIDE LIGHT

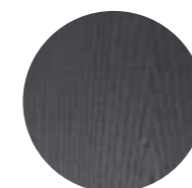

Frassino tinto
nero poro aperto
Black open pore
stained ash

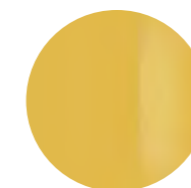

Ottone lucido
Bright brass

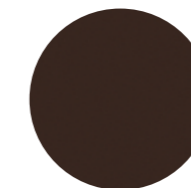

Cristallo retroverniciato
liquirizia brillante
Bright liquorice
painted glass



Cristallo retroverniciato
liquirizia brillante con
incisione a rombi
Bright liquorice painted
glass with rhomboidal
engraved pattern

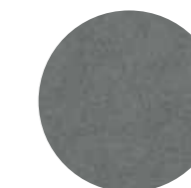

Pelle scamosciata Grey 058
Suede Grey 058

LED 15W
108 lm
3000K
Cable lenght: 1,5mt



▲ VENERE

Struttura in cristallo Champagne satinato e metallo laccato color brunito / Specchio bifacciale orientabile / Vaschette porta oggetti in pelle scamosciata Sand 012.
Satin champagne glass and burnished lacquered metal structure / Rotating double face mirror / Small boxes covered by suede Sand 012.

Venere

Carlo Colombo / 2013

Scrittoio-vanity in legno rivestito in cristallo 6mm temperato e con mensola in appoggio in cristallo 10mm temperato, entrambi retroverniciati nei colori del campionario, nella versione brillante o satinata. Specchio bifacciale diam. 50cm, orientabile (360°). Su richiesta inserto con specchio ingranditore. Cassetti in legno laccato effetto tessuto color castagna. Struttura in metallo laccato color brunito. Vaschette porta oggetti in metallo rivestito in pelle scamosciata Sand 012.

Vanity wooden desk covered by 6mm tempered glass and 10mm tempered shelf, both painted as per samples in the bright or satin version. Rotating(360°) double face mirror diam. 50cm. Magnifying mirrored insert, on request. Chestnut with "fabric" touch effect lacquered drawers. Burnished lacquered metal structure. Small boxes in metal covered by suede Sand 012.



Cm

Versione con specchio
124 x 60 x 136
144 x 60 x 136

Versione senza specchio
124 x 60 x 86
144 x 60 x 86

Inches

Version with mirror
49" x 23³/₄" x 53³/₄"
56³/₄" x 23³/₄" x 53³/₄"

Version without mirror
49" x 23³/₄" x 34"
56³/₄" x 23³/₄" x 34"

[For technical drawing / p. 493](#)

[Pricelist 2023 / p. 238](#)
[Homescapes, intimate portraits/ p. 50](#)

STRUTTURA/STRUCTURE



Sample box

Cristallo brillante/satinato nei colori del campionario
Glass bright/satin version as per samples

PARTI METALLICHE/ METAL PARTS

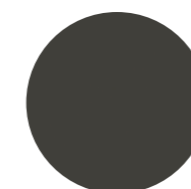

Metallo laccato color brunito
Burnished lacquered metal

CASSETTI/DRAWERS

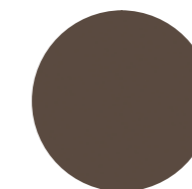

Legno laccato effetto tessuto color castagna
Chestnut with "fabric" touch effect lacquered

PORTAOGGETTI/BOXES



Pelle scamosciata Sand 012
Suede Sand 012

12

Scrittoi e Vanity / Desks and Vanity
TECHNICAL MODULE

Lui | Paolo Maria Fumagalli, 2010

Product information / p. 470

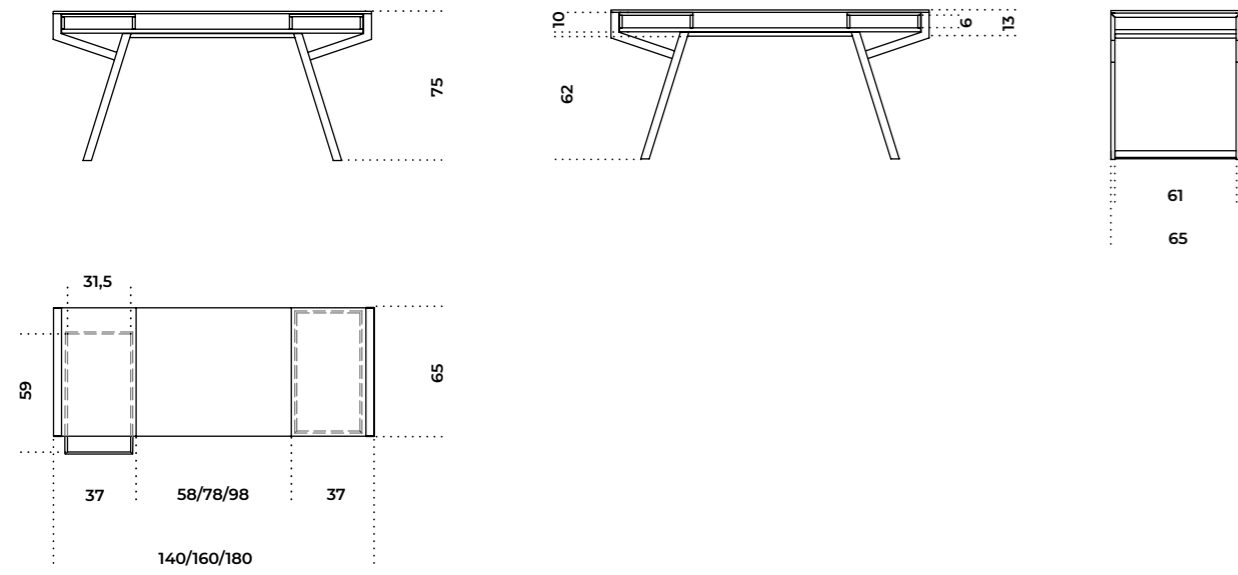

Prism Desk | David / Nicolas, 2019

Product information / p. 476

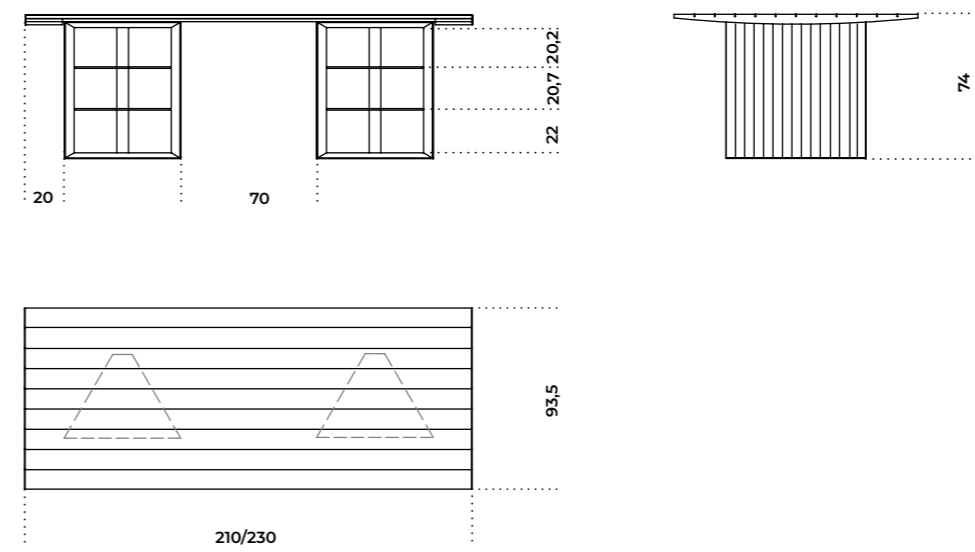

President Junior/President Senior | Studio G&R, 1971

Product information / p. 472

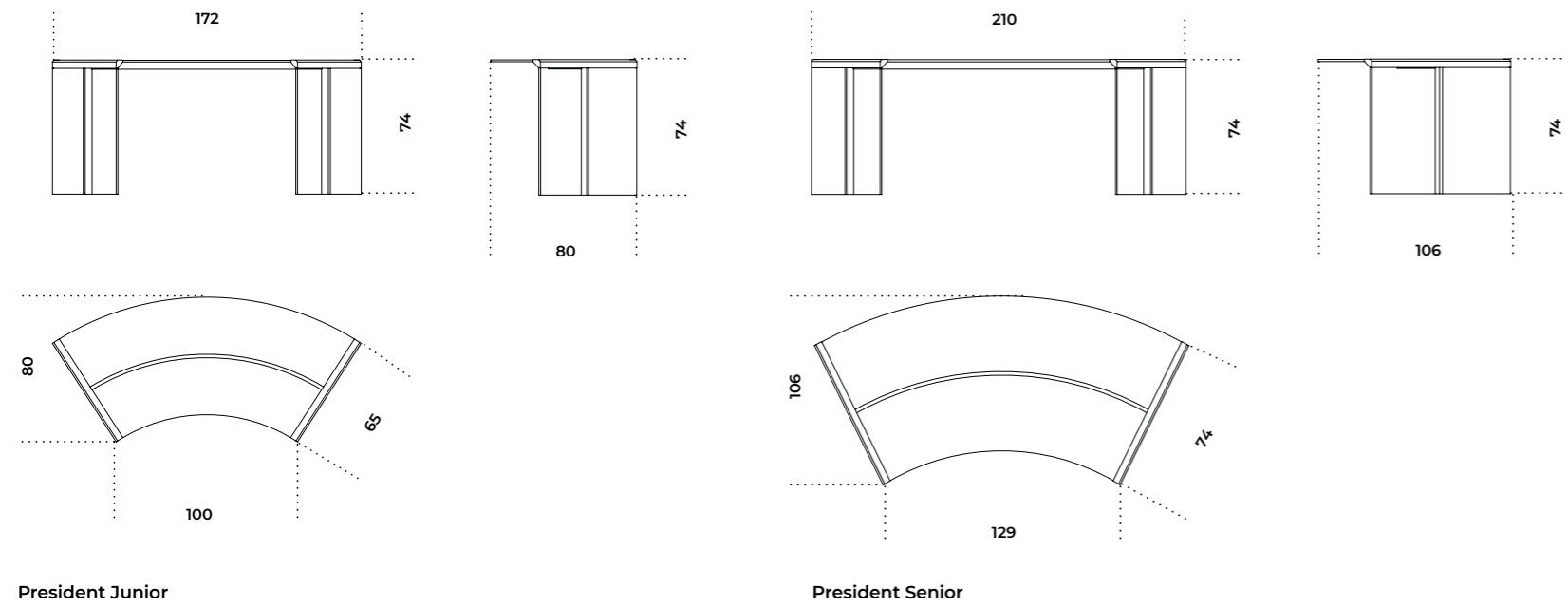

President Junior

President Senior

Selene | Pietro Russo, 2016

Product information / p. 478

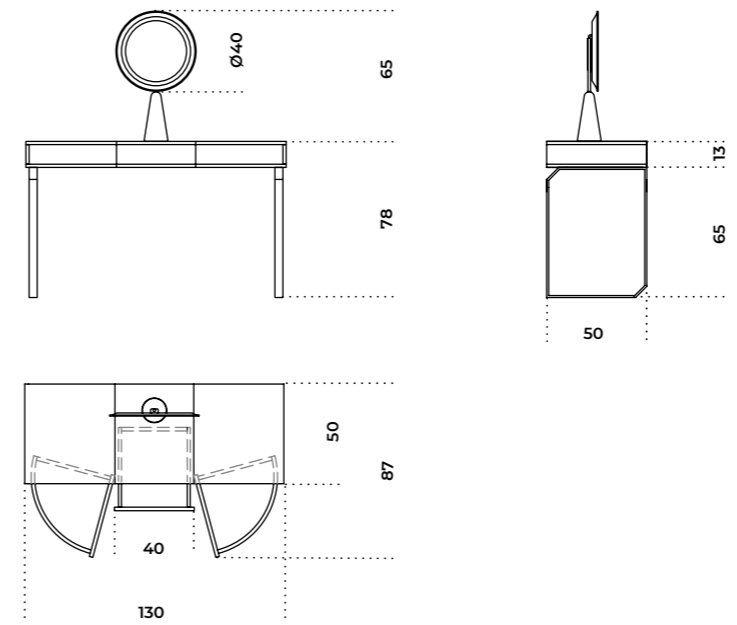

President Junior/President Senior 50th Anniversary | StudioG&R/Silvia Gallotti, 2021

Product information / p. 474

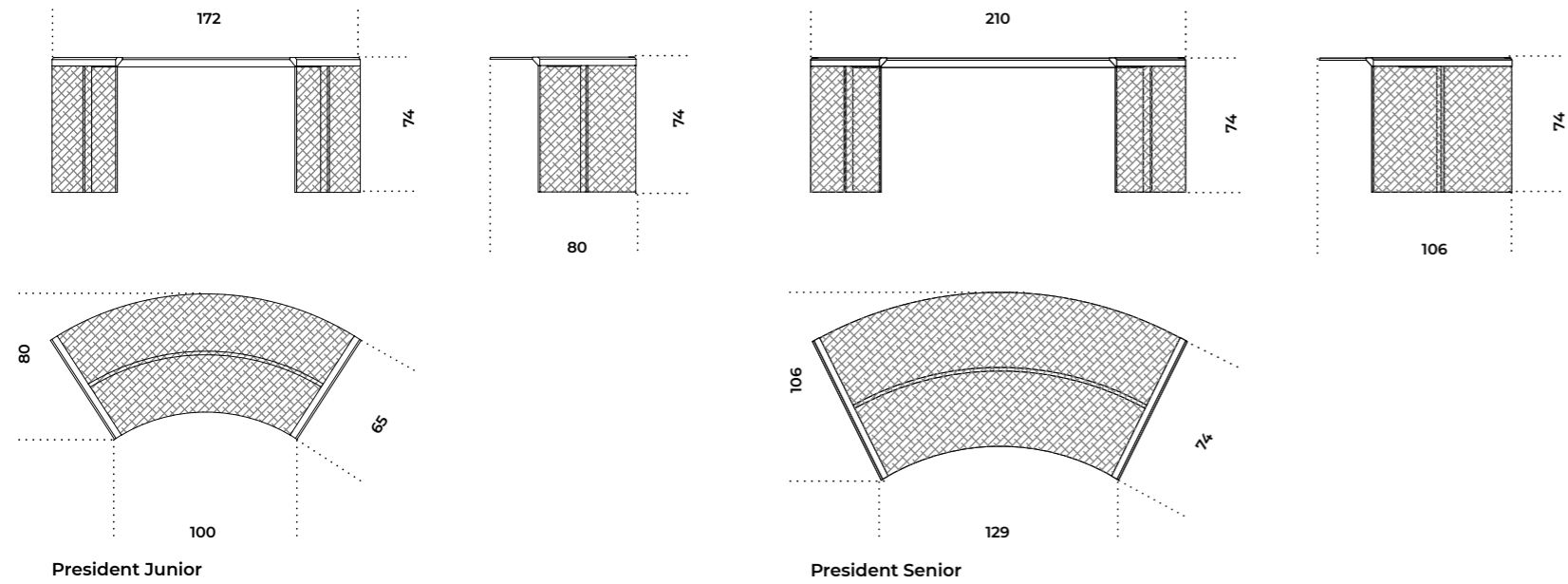

President Junior

President Senior

Soho | Carlo Colombo, 2017

Product information / p. 480

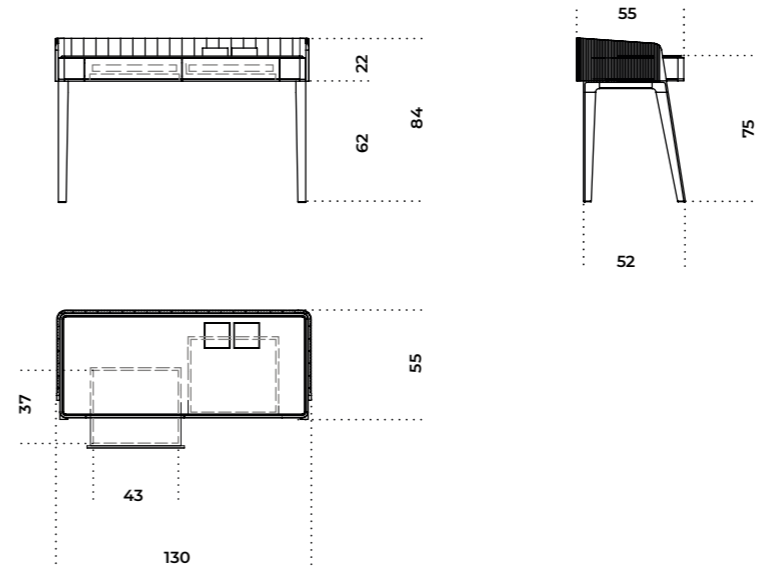

Stami | Studiopepe, 2022

Product information / p. 482

Versione desk senza cassetti
Desk version without drawers

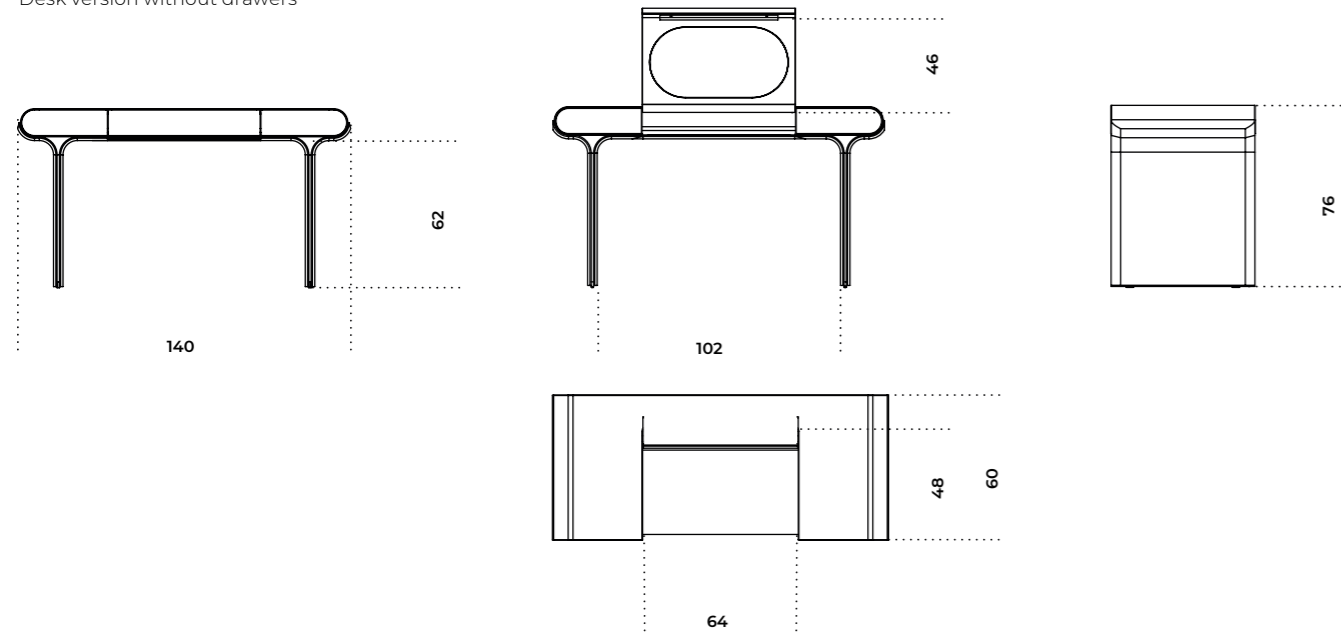

Versione desk con cassetti
Desk version with drawers

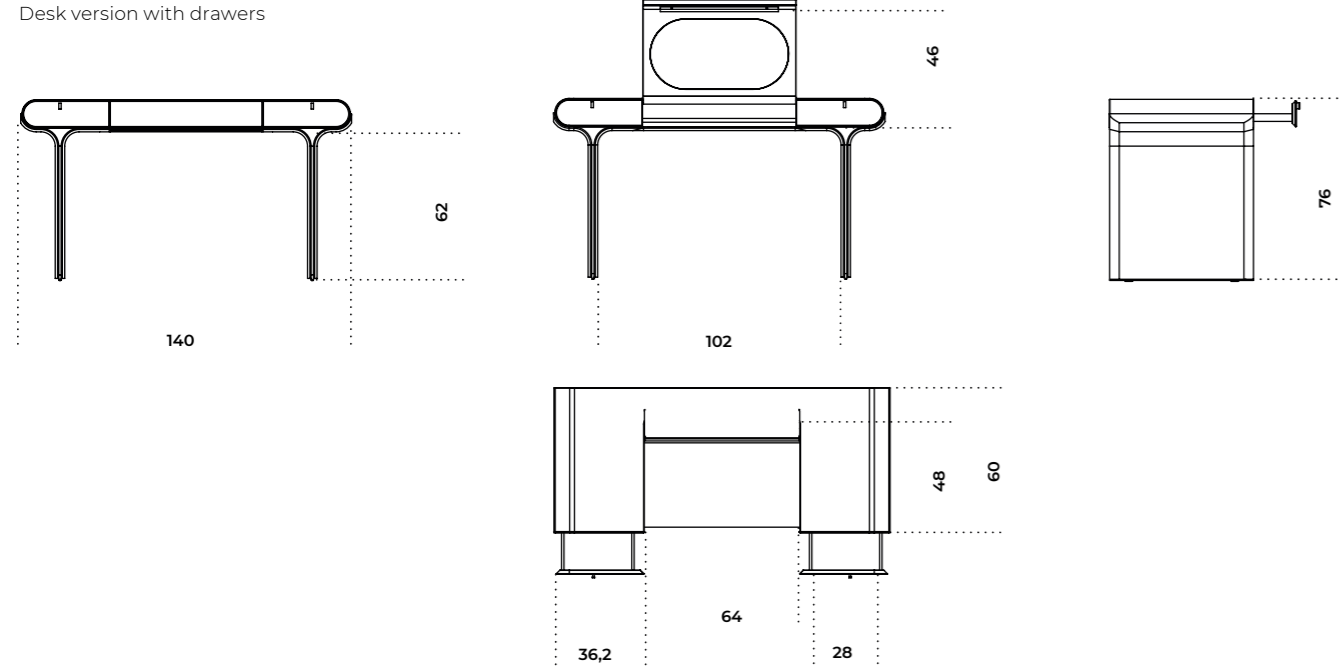

Tama Secrétaire | Carlo Colombo, 2016

Product information / p. 484

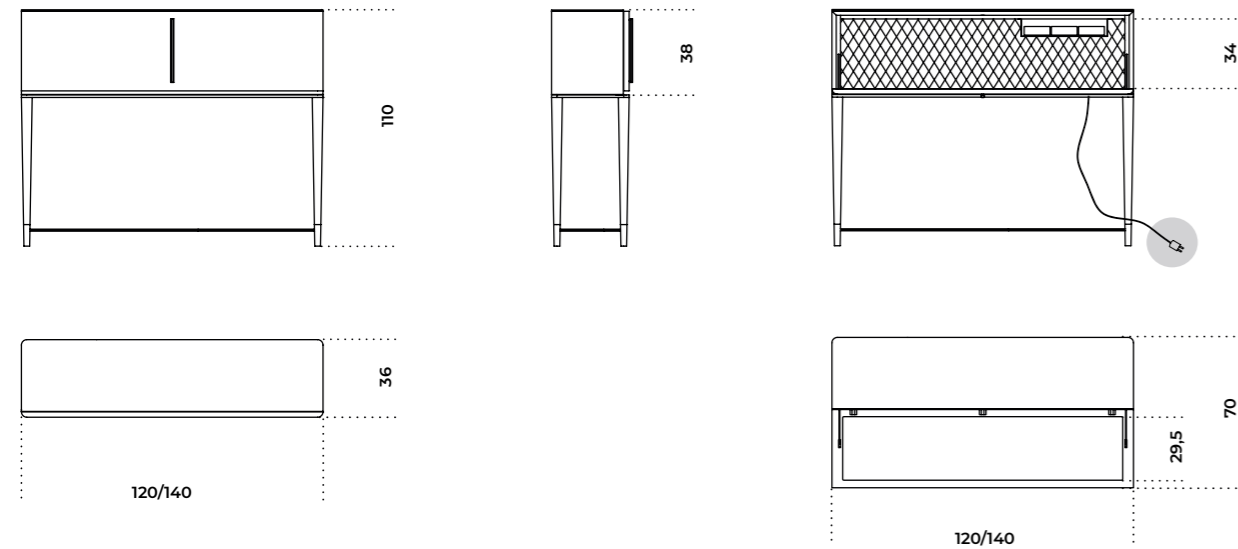

Tipologie di presa:
Types of socket:

- 220V Presa Europea
European socket
- 220V Presa UK
UK socket
- 110V Presa UL USA
USA UL socket

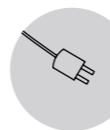

Venere | Carlo Colombo, 2013

Product information / p. 486

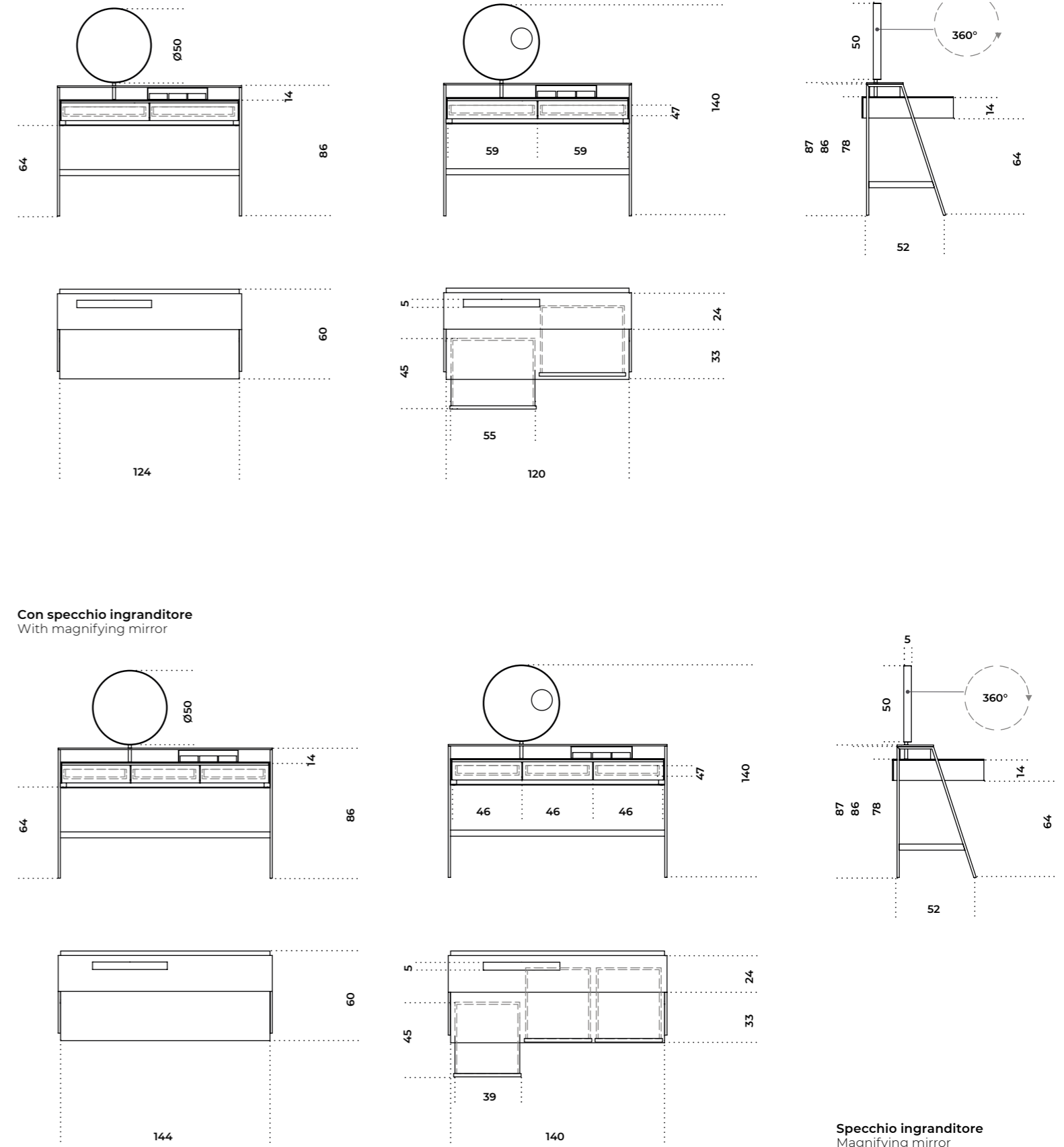

Specchio ingranditore
Magnifying mirror

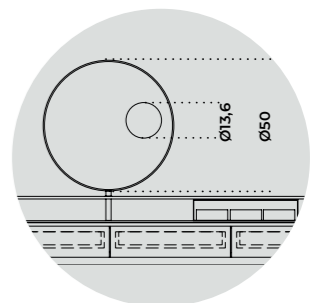

13 Divisori /
Dividers

496 [Chloé](#)
498 [Shield](#)

500 [Informazioni tecniche/
Technical informations](#)



Chloé

Studio G&R / 2016

Paravento con struttura in legno e metallo laccato ottone satinato. Lati rivestiti in specchio extralight e tessuto "Ribon Opaline" di Lelièvre Signature. Basi in marmo lucido naturale Calacatta Vagli Oro. A richiesta con tessuto cliente.

Screen with satin brass lacquered wooden and metal structure. Sides covered by extralight mirror and fabric "Ribon Opaline" by Lelièvre Signature. Natural polished Calacatta Vagli Oro marble bases. Covered by customer's fabric on request.

NOTE TECNICHE SUI MATERIALI

MARMO | Il marmo è un materiale naturale di origine sedimentaria che può presentare particolarità come venature, lievi irregolarità superficiali, colorazioni differenti e cristallizzazioni. Queste peculiarità sono da attribuirsi alla naturalezza del materiale e non sono da considerarsi difetti ma caratteristiche tipiche del marmo. Ogni prodotto risulterà unico, esclusivo e non replicabile.

TECHNICAL INFORMATION ON THE MATERIALS

MARBLE | The marble is a natural material of sedimentary origin that can present particularities such as veins, slight surface irregularities, different colors and crystallizations. These peculiarities are to be attributed to the naturalness of the material and are not to be considered defects but typical characteristics of marble. Each product will be unique, exclusive and non-replicable.



Cm
135 x 15 x 217

Inches
53¼" x 6" x 85½"

[For technical drawing / p. 502](#)

[Pricelist 2023 / p. 191](#)
[Homescapes, embracing beauty / p. 53](#)

STRUTTURA/STRUCTURE



Laccato ottone satinato
Satin brass lacquered

LATI/SIDES



Specchio extralight /
Tessuto "Ribon Opaline"
Extralight mirror /
Fabric "Ribon Opaline"

BASE/BASE



Marmo lucido naturale
Calacatta Vagli Oro
Natural polished
Calacatta Vagli Oro marble



▲ SHIELD
Moduli in legno intarsiato Noce Colore Frisé e Tanganika bianco Frisé
"Colore" Frisé Walnut inlay wood and Tanganika White Frisé modules

Shield

Pietro Russo / 2019

Paravento composto da 4 moduli in legno curvato intarsiato Noce Colore Frisé o Acero Frisé grigio scuro. Interno in Tanganika bianco Frisé. Struttura e accessori in ottone satinato con specchi 6mm extralight bisellati. Ciotola in ottone satinato con fondo rivestito in pelle scamosciata.

! Il legno è un materiale vivo che subisce un naturale processo di ossidazione che può causare cambiamenti cromatici. Venature e tonalità di colore differenti delle lastre non sono da considerarsi come difetti, ma caratteristiche che esaltano l'unicità del materiale.

NOTE TECNICHE SUI MATERIALI

INTARSIO | L'intarsio è una tecnica di lavorazione artigianale utilizzata per ottenere un particolare disegno e si realizza accostando elementi di materiali differenti (come legno e alluminio) oppure dello stesso materiale. Questa lavorazione rende il prodotto unico ed esclusivo. Le eventuali variazioni cromatiche e di venatura del legno sono da considerarsi caratteristiche del materiale stesso e non possono essere controllate.

Screen composed by 4 curved "Colore" Frisé walnut or Maple Frisé dark grey inlaid wooden modules. Inside in Tanganika white Frisé. Satin brass structure and accessories with 6mm extralight bevelled mirrors. Satin brass tray with suede bottom.

! Wood is a living material and the natural oxidation process can cause chromatic changes. Different grain and colour shades of the wooden slabs are not to be considered as defects, but characteristics that enhance the uniqueness of the material.

TECHNICAL INFORMATION ON THE MATERIALS

INLAY | Inlay is an artisanal technique used to obtain a particular design and is made by combining elements of different materials (such as wood and aluminium) or of the same material. This process makes the product unique and exclusive. Any colour and grain variations of the wood are to be considered as characteristics of the material itself and cannot be controlled.



For technical drawing / p. 502

Cm
204 x 39 x 192

Inches
80½" x 15½" x 75¾"

Pricelist 2023 / p. 202
Homescapes, sense of materials / p. 74, 78-79
Homescapes, gentle attitude / pp. 58, 60, 61

MODULI/MODULES

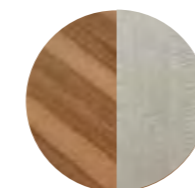

Legno intarsiato
Noce "Colore" Frisé/
Tanganika bianco Frisé
"Colore" Frisé Walnut
inlay wood/
Tanganika White Frisé

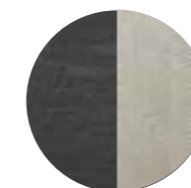

Acero Frisé/
Tanganika bianco Frisé
Maple Frisé dark grey/
Tanganika White Frisé

STRUTTURA E ACCESSORI/ STRUCTURE AND ACCESSORIES



Ottone satinato
Satin brass



Specchio extralight
bisellato
Extralight bevelled mirror

13

Divisori / Dividers
TECHNICAL MODULE

Chloé | Studio G&R, 2016

Product information / p. 496

Fronte
Front

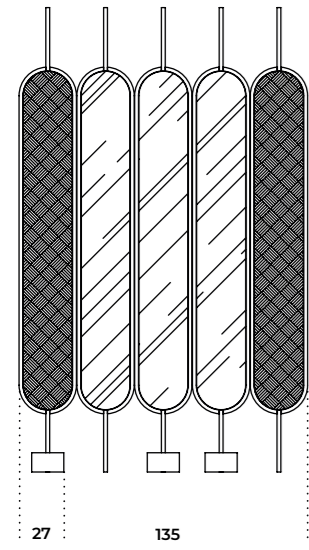

Retro
Back

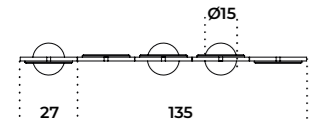
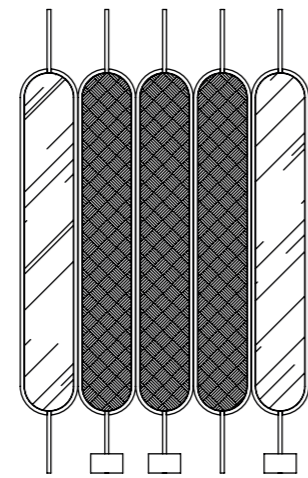

Shield | Pietro Russo, 2019

Product information / p. 498

Fronte
Front

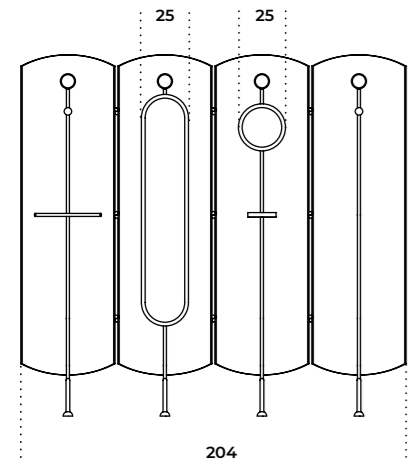

Retro
Back

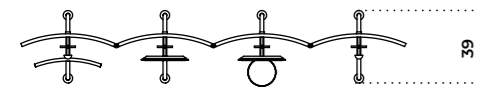
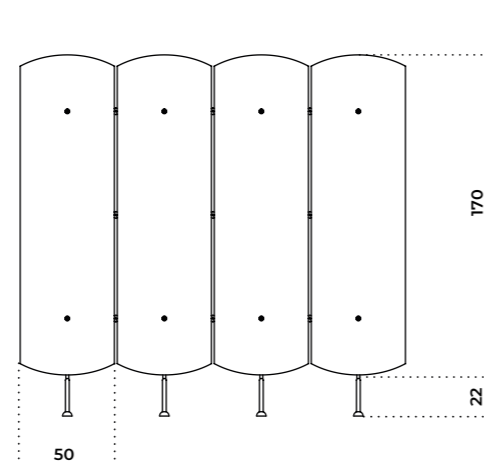

14 Lampade / Lightings

- [506](#) [Bolle](#)
- [508](#) [Bolle Aria](#)
- [510](#) [Bolle Cielo](#)
- [512](#) [Bolle Orizzontale](#)
- [514](#) [Bolle Sola](#)
- [516](#) [Bolle Tavolo 1](#)
- [518](#) [Bolle Tavolo 3](#)
- [520](#) [Bolle Tela](#)
- [522](#) [Bolle Terra](#)
- [524](#) [Bolle Verticale](#)
- [526](#) [Bonfire](#)
- [528](#) [Diantha](#)
- [530](#) [Diantha Terra](#)
- [532](#) [Epsilon](#)
- [534](#) [Epsilon Sola](#)
- [536](#) [Eris](#)
- [538](#) [Jolie](#)
- [540](#) [Jolie Applique](#)
- [542](#) [Key-to-Heaven](#)
- [544](#) [Key-to-Heaven Fix](#)
- [546](#) [Narghilè](#)
- [548](#) [Ori](#)
- [550](#) [Spectrum](#)

- [552](#) [Informazioni tecniche/
Technical informations](#)



Bolle

Massimo Castagna / 2015

Lampada a sospensione a luce LED dimmerabile con 6 o 4 sfere in cristallo trasparente soffiato a bocca. Parti metalliche in ottone brunito a mano. L'altezza può essere realizzata a misura, da un minimo 73 cm (Bolle 4) e di 85 cm (Bolle 6) ad un massimo di 600 cm (incluso corpo luminoso).

Hanging lamp with dimmable LED light with 6 or 4 transparent mouth-blown glass spheres. Metal parts in hand burnished brass. The height can be customised from a minimum of 85cm (Bolle 6) and 73cm (Bolle 4) to a maximum of 600cm (including lights).

Le lampade BOLLE sono fornite complete di lampadine come servizio di cortesia.

As courtesy BOLLE lamps are supplied with light bulbs.

**Versione 4 sfere
composta da:**
2 sfere Ø20 cm / Ø8"
2 sfere Ø25 cm / Ø10"

**Versione 6 sfere
composta da:**
3 sfere Ø20 cm / Ø8"
3 sfere Ø25 cm / Ø10"

**4 spheres version
composed by:**
2 spheres Ø20 cm / Ø8"
2 spheres Ø25 cm / Ø10"

**6 spheres version
composed by:**
3 spheres Ø20 cm / Ø8"
3 spheres Ø25 cm / Ø10"

! Braccetti non regolabili.

Versione 220-240V: la lampada viene fornita con driver per dimmerazione in taglio di fase. Versione 110V: la lampada viene fornita con driver per dimmerazione 1-10V.

In caso di presenza di un diverso sistema di dimmerazione o per connessione con sistema di domotica, si prega di specificare al momento dell'ordine per verificarne la compatibilità.

! Non-adjustable arms.

Version 220-240V: the lamp is supplied with phase-cut driver. Version 110V: the lamp is supplied with 1-10V driver.

In case of need for different dimmer system or for the connection to home automation system, please inform us prior to ordering for checking compatibility.

NOTE TECNICHE SUI MATERIALI

VETRO SOFFIATO A BOCCA | Piccole variazioni dimensionali sono dovute alla lavorazione artigianale del vetro fuso.

OTTONE BRUNITO A MANO | L'ottone brunito a mano è ottenuto da un processo di ossidazione naturale eseguito manualmente. Il risultato di questa lavorazione è un prodotto che può presentare macchie e variazioni di colore che non sono da considerarsi imperfezioni ma caratteristiche che conferiscono ad ogni pezzo una particolare unicità, rendendolo esclusivo.

TECHNICAL INFORMATION ON THE MATERIALS

MOUTH_BLOWN GLASS | Small dimensional variations are due to the handcrafted processing of molten glass.

HAND BURNISHED BRASS | The hand burnished brass is the consequence of hand-made process of natural oxidation. The result of this processing is a product that may show marks and colour variations. These differences are inevitable and should not be considered imperfections but evidence of the hand-crafted process. They enhance the beauty and distinctiveness of a unique piece.



Cm
Versione 4 sfere
70 x 68 x 128*
Versione 6 sfere
90 x 80 x 128*

Inches
4 spheres version
27³/₄" x 27" x 50¹/₂"**
6 spheres version
35¹/₂" x 31¹/₂" x 50¹/₂"**

* H totale incluso sfere

**H total height including spheres

[For technical drawing / p. 556](#)

[Pricelist 2023 / p. 166](#)
[Homescapes, intimate portraits / p. 82](#)
[Homescapes, gentle attitude / p. 103](#)

SFERE/SPHERES



Cristallo trasparente
soffiato a bocca
Transparent mouth-blown
glass

PARTI METALLICHE/ METAL PARTS



Ottone brunito a mano
Hand burnished brass

INFORMAZIONI TECNICHE/ TECHNICAL INFORMATION

CTT: 2700K
CRI: ≥ 80
Light output: 800lm (Bolle4), 1200lm (Bolle6)
Light sources: G4 12V 1,8W each
Dimmability: phase-cut (220-240V), 1-10V (110V)
Weight: ≈20kg





Bolle Aria

Massimo Castagna / 2020

Lampada da parete o soffitto a luce LED dimmerabile con 3 sfere in cristallo trasparente soffiato a bocca. Parti metalliche in ottone brunito a mano.

Le lampade BOLLE ARIA sono fornite complete di lampadine come servizio di cortesia.

Composta da:
2 sfere Ø25 cm / Ø10"
1 sfera Ø30 cm / Ø12"

! Per versione 110V rosone differente, vedi disegni pp.50.

Braccetti non regolabili.

Versione 220-240V: la lampada viene fornita con driver per dimmerazione in taglio di fase.
Versione 110V: la lampada viene fornita con driver per dimmerazione 1-10V.

In caso di presenza di un diverso sistema di dimmerazione o per connessione con sistema di domotica, si prega di specificare al momento dell'ordine per verificarne la compatibilità.

NOTE TECNICHE SUI MATERIALI

VETRO SOFFIATO A BOCCA | Piccole variazioni dimensionali sono dovute alla lavorazione artigianale del vetro fuso.

OTTONE BRUNITO A MANO | L'ottone brunito a mano è ottenuto da un processo di ossidazione naturale eseguito manualmente. Il risultato di questa lavorazione è un prodotto che può presentare macchie e variazioni di colore che non sono da considerarsi imperfezioni ma caratteristiche che conferiscono ad ogni pezzo una particolare unicità, rendendolo esclusivo.

Wall or ceiling fitted lamp with dimmable LED light with 3 transparent mouth-blown glass spheres. Metal parts in hand burnished brass.

As courtesy BOLLE ARIA lamps are supplied with light bulbs.

Composed by:
2 spheres Ø25 cm / Ø10"
1 sphere Ø30 cm / Ø12"

! Different canopy for 110V version, see drawings pp.50.

Non-adjustable arms.

Version 220-240V: the lamp is supplied with phase-cut driver.
Version 110V: the lamp is supplied with 1-10V driver.

In case of need for different dimmer system or for the connection to home automation system, please inform us prior to ordering for checking compatibility.

TECHNICAL INFORMATION ON THE MATERIALS

MOUTH-BLOWN GLASS | Small dimensional variations are due to the handcrafted processing of molten glass.

HAND BURNISHED BRASS | The hand burnished brass is the consequence of hand-made process of natural oxidation. The result of this processing is a product that may show marks and colour variations. These differences are inevitable and should not be considered imperfections but evidence of the hand-crafted process. They enhance the beauty and distinctiveness of a unique piece.



Cm
58 x 54,5 x 60

Inches
23" x 21½" x 23¾"

[For technical drawing / p. 556](#)

[Pricelist 2023 / p. 167](#)
[Homescapes, embracing beauty / pp. 55, 82](#)
[Homescapes, intimate portraits / p. 18](#)
[Homescapes, gentle attitude / pp. 37, 39](#)

SFERE/SPHERES



Cristallo trasparente
soffiato a bocca
Transparent mouth-blown
glass

PARTI METALLICHE/ METAL PARTS



Ottone brunito a mano
Hand burnished brass

INFORMAZIONI TECNICHE/ TECHNICAL INFORMATION

CTT: 2700K
CRI: ≥ 80
Light output: 600lm
Light sources: G4 12V 1,8W each
Dimmability: phase-cut (220-240V), 1-10V (110V)
Weight: ≈8kg



Bolle Cielo

Massimo Castagna / 2020

Lampada a sospensione a luce LED dimmerabile disponibile con 6 o 9 sfere in cristallo trasparente soffiato a bocca. Parti metalliche in ottone brunito a mano. Con cavo elettrico e cavo di acciaio da 4 mt. per regolare l'altezza.

Hanging lamp with dimmable LED light with 6 or 9 transparent mouth-blown glass spheres. Metal parts in hand burnished brass. Supplied with 4 meters long electric and steel cables in order to customize height.

Le lampade BOLLE CIELO sono fornite complete di lampadine come servizio di cortesia.

As courtesy BOLLE CIELO lamps are supplied with light bulbs.

**Versione 6 sfere
composta da:**
6 sfere Ø30 cm / Ø12"

**Versione 9 sfere
composta da:**
9 sfere Ø30 cm / Ø12"

**6 spheres version
composed by:**
6 spheres Ø30 cm / Ø12"

**9 spheres version
composed by:**
9 spheres Ø30 cm / Ø12"

! **Versione 220-240V:** la lampada viene fornita con driver per dimmerazione in taglio di fase.
• **Versione 110V:** la lampada viene fornita con driver per dimmerazione 1-10V.

In caso di presenza di un diverso sistema di dimmerazione o per connessione con sistema di domotica, si prega di specificare al momento dell'ordine per verificarne la compatibilità.

! **Version 220-240V:** the lamp is supplied with phase-cut driver.
• **Version 110V:** the lamp is supplied with 1-10V driver.

In case of need for different dimmer system or for the connection to home automation system, please inform us prior to ordering for checking compatibility.

NOTE TECNICHE SUI MATERIALI

VETRO SOFFIATO A BOCCA | Piccole variazioni dimensionali sono dovute alla lavorazione artigianale del vetro fuso.

OTTONE BRUNITO A MANO | L'ottone brunito a mano è ottenuto da un processo di ossidazione naturale eseguito manualmente. Il risultato di questa lavorazione è un prodotto che può presentare macchie e variazioni di colore che non sono da considerarsi imperfezioni ma caratteristiche che conferiscono ad ogni pezzo una particolare unicità, rendendolo esclusivo.

TECHNICAL INFORMATION ON THE MATERIALS

MOUTH_BLOWN GLASS | Small dimensional variations are due to the handcrafted processing of molten glass.

HAND BURNISHED BRASS | The hand burnished brass is the consequence of hand-made process of natural oxidation. The result of this processing is a product that may show marks and colour variations. These differences are inevitable and should not be considered imperfections but evidence of the hand-crafted process. They enhance the beauty and distinctiveness of a unique piece.



Cm

Versione 6 sfere

82,5 x 84 x 74*

Versione 9 sfere

82,5 x 84 x 74*

* Altezza totale escluso cavo e rosone

Inches

Version 6 spheres

32½" x 33¼" x 29¼"*

Version 9 spheres

32½" x 33¼" x 29¼"*

* Overall height excluding cables and ceiling plate

[For technical drawing / p. 556](#)

[Pricelist 2023 / p.168](#)
[Homescapes, embracing beauty / pp. 36, 75](#)
[Homescapes, gentle attitude / pp. 15, 17](#)

SFERE/SPHERES



Cristallo trasparente soffiato a bocca
Transparent mouth-blown glass

PARTI METALLICHE/ METAL PARTS



Ottone brunito a mano
Hand burnished brass

INFORMAZIONI TECNICHE/ TECHNICAL INFORMATIONS

CTT: 2700K

CRI: ≥ 80

Light output: 1200lm (Bolle Cielo 6),
1800lm (Bolle Cielo 9)

Light sources: G4 12V 1,8W each

Dimmability: phase-cut (220-240V), 1-10V (110V)

Cable lenght: 4mt

Weight: ≈20kg (Bolle Cielo 6), ≈30kg (Bolle Cielo 9)



Bolle Orizzontale

Massimo Castagna / 2019

LED dimmerabile disponibile con 10 sfere oppure 16 sfere in cristallo trasparente soffiato a bocca. Parti metalliche in ottone brunito a mano. In dotazione cavo di 4mt per regolare l'altezza.

Hanging lamp with dimmable LED light. Available 10 or 16 transparent mouth-blown glass spheres. Metal parts in hand burnished brass. Supplied with cable 4mt long to customize height.

Le lampade BOLLE ORIZZONTALE sono fornite complete di lampadine come servizio di cortesia.

As courtesy BOLLE ORIZZONTALE lamps are supplied with light bulbs.

Versione 10 sfere composta da:
2 sfere Ø20 cm / Ø8"
4 sfere Ø25 cm / Ø10"
4 sfere Ø30 cm / Ø12"

Versione 16 sfere composta da:
2 sfere Ø20 cm / Ø8"
6 sfere Ø25 cm / Ø10"
8 sfere Ø30 cm / Ø12"

10 spheres version composed by:
2 spheres Ø20 cm / Ø8"
4 spheres Ø25 cm / Ø10"
4 spheres Ø30 cm / Ø12"

16 spheres version composed by:
2 spheres Ø20 cm / Ø8"
6 spheres Ø25 cm / Ø10"
8 spheres Ø30 cm / Ø12"

! Braccetti non regolabili.

La lampada viene fornita con driver per dimmerazione 1-10V.

In caso di presenza di un diverso sistema di dimmerazione o per connessione con sistema di domotica, si prega di specificare al momento dell'ordine per verificarne la compatibilità.

! Non-adjustable arms.

The lamp is supplied with 1-10V driver.

In case of need for different dimmer system or for the connection to home automation system, please inform us prior to ordering for checking compatibility.

NOTE TECNICHE SUI MATERIALI

VETRO SOFFIATO A BOCCA | Piccole variazioni dimensionali sono dovute alla lavorazione artigianale del vetro fuso.

OTTONE BRUNITO A MANO | L'ottone brunito a mano è ottenuto da un processo di ossidazione naturale eseguito manualmente. Il risultato di questa lavorazione è un prodotto che può presentare macchie e variazioni di colore che non sono da considerarsi imperfezioni ma caratteristiche che conferiscono ad ogni pezzo una particolare unicità, rendendolo esclusivo.

TECHNICAL INFORMATION ON THE MATERIALS

MOUTH_BLOWN GLASS | Small dimensional variations are due to the handcrafted processing of molten glass.

HAND BURNISHED BRASS | The hand burnished brass is the consequence of hand-made process of natural oxidation. The result of this processing is a product that may show marks and colour variations. These differences are inevitable and should not be considered imperfections but evidence of the hand-crafted process. They enhance the beauty and distinctiveness of a unique piece.

Cm
Versione 10 sfere
200 x 120 x 85
Versione 16 sfere
300 x 120 x 85

Inches
Version 10 spheres
78¾" x 47¼" x 33½"
Version 16 spheres
118¾" x 47¼" x 33½"

[For technical drawing / p. 557](#)

[Pricelist 2023 / p. 169](#)
[Homescapes, sense of materials / p. 44](#)
[Homescapes, embracing beauty / p. 16](#)
[Homescapes, gentle attitude / pp. 81, 83](#)

SFERE/SPHERES



Cristallo trasparente soffiato a bocca
Transparent mouth-blown glass

PARTI METALLICHE/ METAL PARTS



Ottone brunito a mano
Hand burnished brass

INFORMAZIONI TECNICHE/ TECHNICAL INFORMATIONS

CTT: 2700K
CRI: ≥ 80
Light output: 2000lm (Bolle Orizzontale 10), 3200lm (Bolle Orizzontale 16)
Light sources: G4 12V 1,8W each
Dimmability: 1-10V
Cable lenght: 4mt
Weight: ≈ 41kg (Bolle Orizzontale 10), ≈ 61kg (Bolle Orizzontale 16)





▲ **BOLLE SOLA**
 n.2 Bolle Sola Ø25 e n.2 Bolle Sola Ø20
 n.2 Bolle Sola Ø25 and n.2 Bolle Sola Ø20

Bolle Sola

Massimo Castagna / 2015

Lampada a sospensione a luce LED non dimmerabile. Sfera in cristallo trasparente soffiato a bocca. Parti metalliche in ottone brunito a mano. In dotazione cavo da 4mt per regolare l'altezza. Su richiesta realizzabili set da 3 e 5 lampade con un unico rosone, questa versione è dimmerabile solo per voltaggio 220-240V.

Le lampade BOLLE SOLA sono fornite complete di lampadine come servizio di cortesia.

Rosone unico set 3 pezzi:
 2 sfere Ø20 cm / Ø8"
 1 sfera Ø25 cm / Ø10"

Rosone unico set 5 pezzi:
 3 sfere Ø20 cm / Ø8"
 2 sfere Ø25 cm / Ø10"

! Per versione 110V rosone differente, vedi disegni pp.50

La composizione da 3 e 5 lampade con un unico rosone è dimmerabile solo per voltaggio 220-240V. Questa versione viene fornita con driver per dimmerazione in taglio di fase.

In caso di presenza di un diverso sistema di dimmerazione o per connessione con sistema di domotica, si prega di specificare al momento dell'ordine per verificarne la compatibilità.

NOTE TECNICHE SUI MATERIALI

VETRO SOFFIATO A BOCCA | Piccole variazioni dimensionali sono dovute alla lavorazione artigianale del vetro fuso.

OTTONE BRUNITO A MANO | L'ottone brunito a mano è ottenuto da un processo di ossidazione naturale eseguito manualmente. Il risultato di questa lavorazione è un prodotto che può presentare macchie e variazioni di colore che non sono da considerarsi imperfezioni ma caratteristiche che conferiscono ad ogni pezzo una particolare unicità, rendendolo esclusivo.

Hanging lamp with LED light (not dimmable). Transparent mouth-blown glass sphere. Metal parts in hand burnished brass. Supplied with cable 4mt long to customize height. On request set of 3 or 5 lamps with unique canopy, this version is dimmable only for 220-240V voltage.

As courtesy BOLLE SOLA lamps are supplied with light bulbs.

Unique canopy set of 3 pcs:
 2 spheres Ø20 cm / Ø8"
 1 sphere Ø25 cm / Ø10"

Unique canopy set of 5 pcs:
 3 spheres Ø20 cm / Ø8"
 2 spheres Ø25 cm / Ø10"

! Different canopy for 110V version, see drawings pp.50.

The composition of 3 or 5 lamps with unique canopy is dimmable only for 220-240V voltage. This version is supplied with phase-cut driver.

In case of need for different dimmer system or for the connection to home automation system, please inform us prior to ordering for checking compatibility.

TECHNICAL INFORMATION ON THE MATERIALS

MOUTH_BLOWN GLASS | Small dimensional variations are due to the handcrafted processing of molten glass.

HAND BURNISHED BRASS | The hand burnished brass is the consequence of hand-made process of natural oxidation. The result of this processing is a product that may show marks and colour variations. These differences are inevitable and should not be considered imperfections but evidence of the hand-crafted process. They enhance the beauty and distinctiveness of a unique piece.



Cm
 Ø20 x 50,5
 Ø25 x 62

Inches
 Ø8" x 20"
 Ø10" x 24½"

[For technical drawing / p. 557](#)

[Pricelist 2023 / p. 170](#)
[Homescapes, sense of materials / pp. 73, 110](#)
[Homescapes, intimate portraits / p. 40](#)

SFERE/SPHERES



Cristallo trasparente soffiato a bocca
 Transparent mouth-blown glass

PARTI METALLICHE/ METAL PARTS



Ottone brunito a mano
 Hand burnished brass

INFORMAZIONI TECNICHE/ TECHNICAL INFORMATIONS

CTT: 2700K
CRI: ≥ 80
 Light output: 200lm
 Light sources: G4 12V 1,8W each
 Dimmability: NO - Dimmable phase-cut just for 3-5 lamps version (only for 220-240V)
 Cable length: 4mt
 Weight: ≈5kg





Bolle Tavolo 1

Massimo Castagna / 2015

Lampada da tavolo singola a luce LED non dimmerabile. Sfera in cristallo trasparente soffiato a bocca. Parti metalliche in ottone brunito a mano.

Le lampade BOLLE TAVOLO 1 sono fornite complete di lampadine come servizio di cortesia.

Composta da:
1 sfera Ø25 cm/ Ø10"

NOTE TECNICHE SUI MATERIALI

VETRO SOFFIATO A BOCCA | Piccole variazioni dimensionali sono dovute alla lavorazione artigianale del vetro fuso.

OTTONE BRUNITO A MANO | L'ottone brunito a mano è ottenuto da un processo di ossidazione naturale eseguito manualmente. Il risultato di questa lavorazione è un prodotto che può presentare macchie e variazioni di colore che non sono da considerarsi imperfezioni ma caratteristiche che conferiscono ad ogni pezzo una particolare unicità, rendendolo esclusivo.

Single table lamp with LED light (not dimmable). Transparent mouth-blown glass sphere. Metal parts in hand burnished brass.

As courtesy BOLLE TAVOLO 1 lamps are supplied with light bulbs.

Composed by:
1 sphere Ø25 cm/ Ø10"

TECHNICAL INFORMATION ON THE MATERIALS

MOUTH_BLOWN GLASS | Small dimensional variations are due to the handcrafted processing of molten glass.

HAND BURNISHED BRASS | The hand burnished brass is the consequence of hand-made process of natural oxidation. The result of this processing is a product that may show marks and colour variations. These differences are inevitable and should not be considered imperfections but evidence of the hand-crafted process. They enhance the beauty and distinctiveness of a unique piece.



Cm
Ø26 x 26 x 28

Inches
Ø10¼" x 10¼" x 11¼"

[For technical drawing / p. 557](#)

[Pricelist 2023 / p. 171](#)
[Homescapes, intimate portraits / p. 88](#)

SFERA/SPHERE



Cristallo trasparente
soffiato a bocca
Transparent mouth-blown
glass

PARTI METALLICHE/ METAL PARTS



Ottone brunito a mano
Hand burnished brass

INFORMAZIONI TECNICHE/ TECHNICAL INFORMATIONS

CTT: 2700K
CRI: ≥ 80
Light output: 200lm
Light sources: G4 12V 1,8W each
Dimmability: NO
Cable lenght: 1,5mt



Bolle Tavolo 3

Massimo Castagna / 2015



Lampada da tavolo a luce LED dimmerabile con 3 sfere in cristallo trasparente soffiato a bocca. Parti metalliche in ottone brunito a mano. Dimmer presente sul cavo di alimentazione.

Table lamp with dimmable LED light with 3 transparent mouth-blown glass spheres. Metal parts in hand burnished brass. Dimmer on the power cable.

Le lampade BOLLE TAVOLO 3 sono fornite complete di lampadine come servizio di cortesia.

As courtesy BOLLE TAVOLO 3 lamps are supplied with light bulbs.

Composta da:

1 sfera Ø20 cm / Ø8"
2 sfere Ø25 cm / Ø10"

Composed by:

1 sphere Ø20 cm / Ø8"
2 spheres Ø25 cm / Ø10"

NOTE TECNICHE SUI MATERIALI

VETRO SOFFIATO A BOCCA | Piccole variazioni dimensionali sono dovute alla lavorazione artigianale del vetro fuso.

TECHNICAL INFORMATION ON THE MATERIALS

MOUTH-BLOWN GLASS | Small dimensional variations are due to the handcrafted processing of molten glass.

OTTONE BRUNITO A MANO | L'ottone brunito a mano è ottenuto da un processo di ossidazione naturale eseguito manualmente. Il risultato di questa lavorazione è un prodotto che può presentare macchie e variazioni di colore che non sono da considerarsi imperfezioni ma caratteristiche che conferiscono ad ogni pezzo una particolare unicità, rendendolo esclusivo.

HAND BURNISHED BRASS | The hand burnished brass is the consequence of hand-made process of natural oxidation. The result of this processing is a product that may show marks and colour variations. These differences are inevitable and should not be considered imperfections but evidence of the hand-crafted process. They enhance the beauty and distinctiveness of a unique piece.



Cm
58 x 52 x 44

Inches
23" x 20½" x 17½"

[For technical drawing / p. 558](#)

[Pricelist 2023 / p. 172](#)
[Homescapes, sense of materials / pp. 32, 89](#)
[Homescapes, embracing beauty / p. 78](#)

SFERE/SPHERES



Cristallo trasparente
soffiato a bocca
Transparent mouth-blown
glass

PARTI METALLICHE/ METAL PARTS



Ottone brunito a mano
Hand burnished brass

INFORMAZIONI TECNICHE/ TECHNICAL INFORMATIONS

CTT: 2700K
CRI: ≥ 80
Light output: 600lm
Light sources: G4 12V 1,8W each
Dimmability: push button dimmer on the power cable
Cable lenght: 1,5mt





Bolle Tela

Massimo Castagna / 2018

Lampada a sospensione a luce LED dimmerabile con 6 o 8 sfere in cristallo trasparente soffiato a bocca. Parti metalliche in ottone brunito a mano. In dotazione cavo di 4mt per regolare l'altezza.

Hanging lamp with dimmable LED light with 6 or 8 transparent mouth-blown glass spheres. Metal parts in hand burnished brass. Supplied with cable 4mt long to customize height.

Le lampade BOLLE TELA sono fornite complete di lampadine come servizio di cortesia.

As courtesy BOLLE TELA lamps are supplied with light bulbs.

**Versione 6 sfere
composta da:**

2 sfere Ø20 cm / Ø8"
2 sfere Ø25 cm / Ø10"
2 sfere Ø30 cm / Ø12"

**Versione 8 sfere
composta da:**

2 sfere Ø20 cm / Ø8"
3 sfere Ø25 cm / Ø10"
3 sfere Ø30 cm / Ø12"

**6 spheres version
composed by:**

2 spheres Ø20 cm / Ø8"
2 spheres Ø25 cm / Ø10"
2 spheres Ø30 cm / Ø12"

**8 spheres version
composed by:**

2 spheres Ø20 cm / Ø8"
3 spheres Ø25 cm / Ø10"
3 spheres Ø30 cm / Ø12"

! Braccetti non regolabili.

La lampada viene fornita con driver per dimmerazione 1-10V.

In caso di presenza di un diverso sistema di dimmerazione o per connessione con sistema di domotica, si prega di specificare al momento dell'ordine per verificarne la compatibilità.

! Non-adjustable arms.

The lamp is supplied with 1-10V driver.

In case of need for different dimmer system or for the connection to home automation system, please inform us prior to ordering for checking compatibility.

NOTE TECNICHE SUI MATERIALI

VETRO SOFFIATO A BOCCA | Piccole variazioni dimensionali sono dovute alla lavorazione artigianale del vetro fuso.

OTTONE BRUNITO A MANO | L'ottone brunito a mano è ottenuto da un processo di ossidazione naturale eseguito manualmente. Il risultato di questa lavorazione è un prodotto che può presentare macchie e variazioni di colore che non sono da considerarsi imperfezioni ma caratteristiche che conferiscono ad ogni pezzo una particolare unicità, rendendolo esclusivo.

TECHNICAL INFORMATION ON THE MATERIALS

MOUTH_BLOWN GLASS | Small dimensional variations are due to the handcrafted processing of molten glass.

HAND BURNISHED BRASS | The hand burnished brass is the consequence of hand-made process of natural oxidation. The result of this processing is a product that may show marks and colour variations. These differences are inevitable and should not be considered imperfections but evidence of the hand-crafted process. They enhance the beauty and distinctiveness of a unique piece.



Cm

Versione 6 sfere

85 x 70 x 100

Versione 8 sfere

85 x 75 x 180

Inches

Version 6 spheres

33½" x 27¾" x 39½"

Version 8 spheres

33½" x 29¾" x 71"

[For technical drawing / p. 558](#)

[Pricelist 2023 / p. 173](#)

[Homescapes, sense of materials / p. 60](#)

[Homescapes, embracing beauty / p. 25](#)

[Homescapes, gentle attitude / p. 69](#)

SFERE/SPHERES



Cristallo trasparente
soffiato a bocca
Transparent mouth-blown
glass

**PARTI METALLICHE/
METAL PARTS**



Ottone brunito a mano
Hand burnished brass

**INFORMAZIONI TECNICHE/
TECHNICAL INFORMATIONS**

CTT: 2700K

CRI: ≥ 80

Light output: 1200lm (Bolle Tela 6), 1600lm (Bolle Tela 8)

Light sources: G4 12V 1,8W each

Dimmability: 1-10V

Cable lenght: 4mt

Weight: ≈25kg (Bolle Tela 6), ≈40kg (Bolle Tela 8)



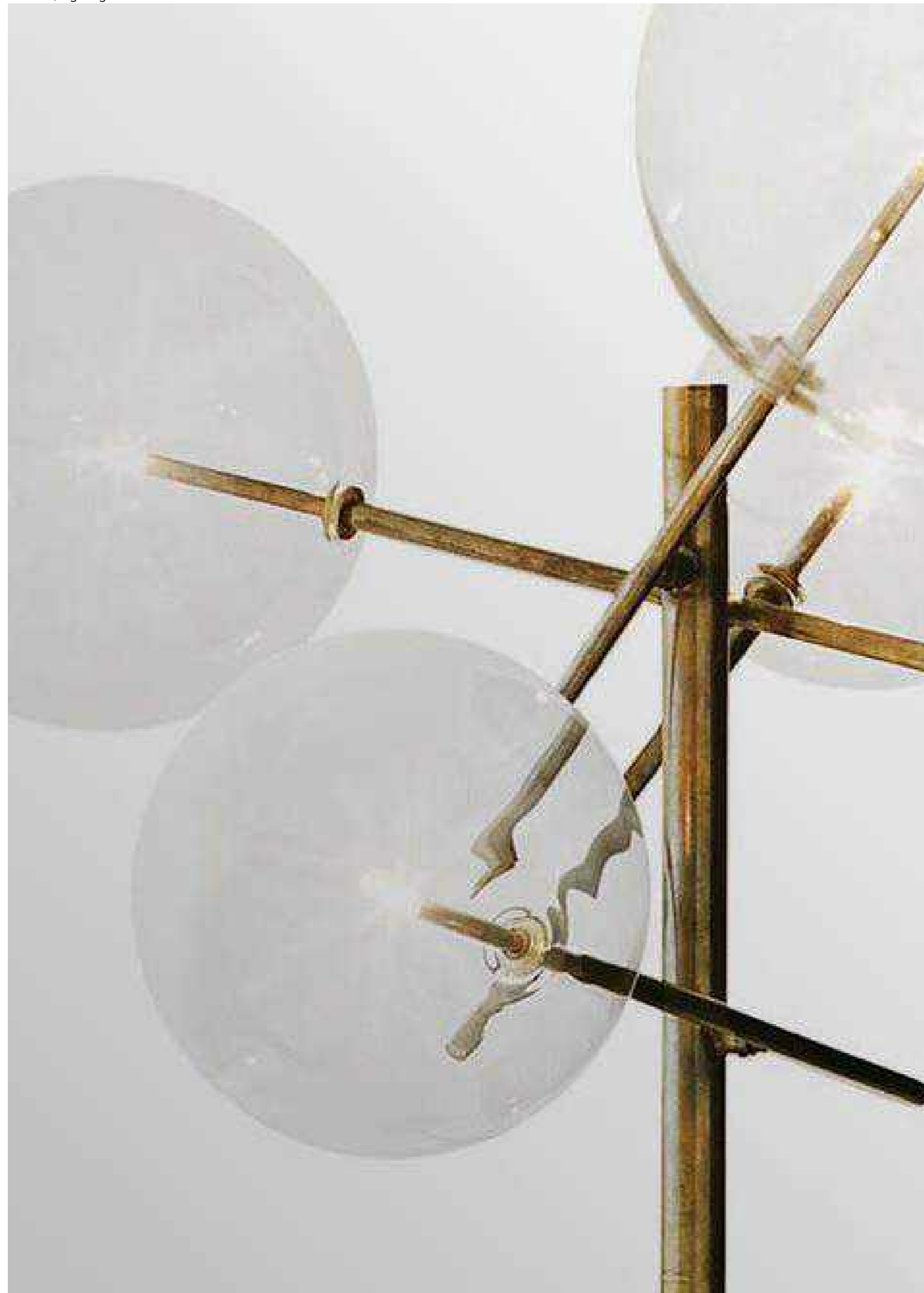

Bolle Terra

Massimo Castagna / 2015

Lampada da terra a luce LED dimmerabile. Sfere in cristallo trasparente soffiato a bocca. Parti metalliche in ottone brunito a mano. Dimmer presente sul cavo di alimentazione.

Floor lamp with dimmable LED light. Transparent mouth-blown glass spheres. Metal parts in hand burnished brass. Dimmer on the power cable.

Le lampade BOLLE TERRA sono fornite complete di lampadine come servizio di cortesia.

As courtesy BOLLE TERRA lamps are supplied with light bulbs.

Composta da:
2 sfere Ø20 cm / Ø8"
2 sfere Ø25 cm / Ø10"

Composed by:
2 spheres Ø20 cm / Ø8"
2 spheres Ø25 cm / Ø10"

! Braccetti non regolabili.

! Non-adjustable arms.

NOTE TECNICHE SUI MATERIALI

VETRO SOFFIATO A BOCCA | Piccole variazioni dimensionali sono dovute alla lavorazione artigianale del vetro fuso.

TECHNICAL INFORMATION ON THE MATERIALS

MOUTH_BLOWN GLASS | Small dimensional variations are due to the handcrafted processing of molten glass.

OTTONE BRUNITO A MANO | L'ottone brunito a mano è ottenuto da un processo di ossidazione naturale eseguito manualmente. Il risultato di questa lavorazione è un prodotto che può presentare macchie e variazioni di colore che non sono da considerarsi imperfezioni ma caratteristiche che conferiscono ad ogni pezzo una particolare unicità, rendendolo esclusivo.

HAND BURNISHED BRASS | The hand burnished brass is the consequence of hand-made process of natural oxidation. The result of this processing is a product that may show marks and colour variations. These differences are inevitable and should not be considered imperfections but evidence of the hand-crafted process. They enhance the beauty and distinctiveness of a unique piece.



[For technical drawing / p. 558](#)

[Pricelist 2023 / p. 174](#)
[Homescapes, embracing beauty / pp. 41, 100](#)
[Homescapes, intimate portraits / p. 89](#)

Cm
72 x 68 x 167

Inches
28½" x 27" x 65¾"

SFERE/SPHERES



Cristallo trasparente
soffiato a bocca
Transparent mouth-blown
glass

PARTI METALLICHE/ METAL PARTS



Ottone brunito a mano
Hand burnished brass

INFORMAZIONI TECNICHE/ TECHNICAL INFORMATIONS

CTT: 2700K
CRI: ≥ 80
Light output: 800lm
Light sources: G4 12V 1,8W each
Dimmability: push button dimmer on the power cable
Cable lenght: 2,2mt





Bolle Verticale

Massimo Castagna / 2022

Lampada telescopica terra-soffitto a luce LED dimmerabile dotata di 7 sfere in cristallo trasparente soffiato a bocca. Struttura del corpo luce in ottone brunito a mano. Parte telescopica in metallo brunito scuro. Altezza regolabile da 260 a 320cm con sistema di fissaggio a soffitto.

Le lampade BOLLE VERTICALE sono fornite complete di lampadine come servizio di cortesia.

Composta da:
1 sfere Ø20 cm / Ø8"
3 sfere Ø25 cm / Ø10"
3 sfere Ø30 cm / Ø12"

NOTE TECNICHE SUI MATERIALI

VETRO SOFFIATO A BOCCA | Piccole variazioni dimensionali sono dovute alla lavorazione artigianale del vetro fuso.

OTTONE BRUNITO A MANO | L'ottone brunito a mano è ottenuto da un processo di ossidazione naturale eseguito manualmente. Il risultato di questa lavorazione è un prodotto che può presentare macchie e variazioni di colore che non sono da considerarsi imperfezioni ma caratteristiche che conferiscono ad ogni pezzo una particolare unicità, rendendolo esclusivo.

Floor lamp with dimmable LED light. Transparent mouth-blown glass spheres. Metal parts in hand burnished brass. Dimmer on the power cable.

As courtesy BOLLE VERTICALE lamps are supplied with light bulbs.

Composed by:
1 sfere Ø20 cm / Ø8"
3 sfere Ø25 cm / Ø10"
3 sfere Ø30 cm / Ø12"

TECHNICAL INFORMATION ON THE MATERIALS

MOUTH_BLOWN GLASS | Small dimensional variations are due to the handcrafted processing of molten glass.

HAND BURNISHED BRASS | The hand burnished brass is the consequence of hand-made process of natural oxidation. The result of this processing is a product that may show marks and colour variations. These differences are inevitable and should not be considered imperfections but evidence of the hand-crafted process. They enhance the beauty and distinctiveness of a unique piece.



Cm
65,5 x 69,5 x 260/320

Inches
26" x 27½" x 102½"/126"

[For technical drawing / p. 559](#)

[Pricelist 2023 / p. 175](#)
[Homescapes, gentle attitude / p. 48](#)

SFERE/SPHERES



Cristallo trasparente soffiato a bocca
Transparent mouth-blown glass

PARTI METALLICHE/ METAL PARTS



Ottone brunito a mano
Hand burnished brass

PARTI TELESCOPICA/ TELESCOPIC PARTS



Metallo brunito scuro
Dark burnished metal

INFORMAZIONI TECNICHE/ TECHNICAL INFORMATIONS

CTT: 2700K
CRI: ≥ 80
Light output: 700lm
Light sources: G4 12V 1W each
Dimmability: Yes
Cable length: 1,5mt





▲ **BONFIRE STRIPES**
Vetro fuso cannettato Calendula (bronzo)
Calendula (bronze) molten ribbed and curved glass

Bonfire

Studiopepe / 2020

Lampada a LED da tavolo in vetro fuso curvato. Disponibile anche nella versione "Stripes" in vetro fuso cannettato e curvato. Realizzabile nei colori Calendula (bronzo) e Mirto (verde).
Struttura metallica in finitura cromo nero.
Cavo elettrico in seta nera 1,5 mt.

NOTE TECNICHE SUI MATERIALI

VETRO FUSO | Eventuali piccole bolle e segni presenti sulla superficie sono dovuti alle lavorazioni del vetro, da non considerarsi difetti.
Piccole variazioni dimensionali sono dovute alla lavorazione artigianale del vetro fuso.

LED table lamp made of molten curved glass. Also available in the "Stripes" version with molten ribbed and curved glass. Available in the colours Calendula (bronze) and Mirto (green).
Metallic structure in black chrome.
1,5 meter long electric cable in black silk.

TECHNICAL INFORMATION ON THE MATERIALS

MOLTEN GLASS | Any small bubbles and marks present on the surface are due to the production of this type of glass and are therefore not to be considered defects.
Small dimensional variations are due to the handcrafted processing of molten glass.



[For technical drawing / p. 559](#)

Cm
33 x 20 x 30
33 x 20 x 50

Inches
13" x 8" x 12"
13" x 8" x 19¼"

[Pricelist 2023 / p. 176](#)
[Homescapes, embracing beauty / p. 96](#)
[Homescapes, intimate portraits / p. 33](#)
[Homescapes, gentle attitude / pp. 45, 86, 87](#)

VETRO FUSO/ MOLTEN GLASS



Calendula (bronzo)
Calendula (bronze)

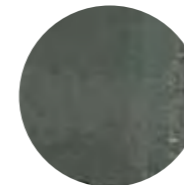

Mirto (verde)
Mirto (green)

STRUTTURA/STRUCTURE

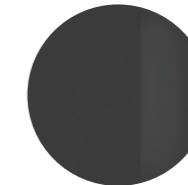

Cromo nero
Black chrome

VETRO FUSO CANNETTATO (Versione stripes)/ MOLTEN RIBBED GLASS (Stripes version)



Calendula (bronzo)
Calendula (bronze)

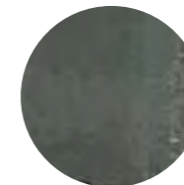

Mirto (verde)
Mirto (green)

INFORMAZIONI TECNICHE/ TECHNICAL INFORMATIONS

CTT: 3000K
CRI: ≥ 80
Light output: 595lm
Light sources: LED module 5,8W 500mA
Dimmability: touch button
Cable length: 1,5mt





Diantha

Massimo Castagna / 2017

Lampada a sospensione a luce LED dimmerabile. Cristallo soffiato a bocca e verniciato bronzo. Parti metalliche in nero bronzato.

Hanging lamp with dimmable LED light. Mouth-blown and bronze painted glass. Bronzed black metal parts.

Le lampade DIANTHA sono fornite complete di lampadine come servizio di cortesia.

As courtesy DIANTHA lamps are supplied with light bulbs.

! Versione 220-240V: la lampada viene fornita con driver per dimmerazione in taglio di fase.
 • Versione 110V: la lampada viene fornita con driver per dimmerazione 1-10V.

! Version 220-240V: the lamp is supplied with phase-cut driver.
 • Version 110V: the lamp is supplied with 1-10V driver.

In caso di presenza di un diverso sistema di dimmerazione o per connessione con sistema di domotica, si prega di specificare al momento dell'ordine per verificarne la compatibilità.

In case of need for different dimmer system or for the connection to home automation system, please inform us prior to ordering for checking compatibility.



• DH



• DVL

	Cm	Inches
DH	157 x 84 x 110	62 " x 33¼" x 43½"
DVS	122 x 123 x 123	48¼" x 48½" x 48½"
DVL	153 x 144 x 220	60¼" x 56¾" x 86¾"

[For technical drawing / p. 559](#)

[Pricelist 2023 / p. 177](#)
[Homescapes, gentle attitude / pp. 86, 87](#)

CRISTALLO/GLASS

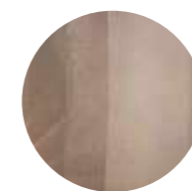

Cristallo soffiato a bocca
 verniciato bronzo
 Mouth blow bronze
 painted glass

PARTI METALLICHE/ METAL PARTS



Nero bronzato
 Bronzed black

INFORMAZIONI TECNICHE/ TECHNICAL INFORMATION

CTT: 2700K
 CRI: ≥ 80
 Light output: 1200lm
 Light sources: G4 12V 1,8W each
 Dimmability: phase-cut (220-240V), 1-10V (110V)
 Weight: ≈11kg (DH), ≈17kg (DVS), ≈20kg (DVL)





Diantha Terra

Massimo Castagna / 2018

Lampada da terra a luce LED dimmerabile. Cristallo soffiato a bocca e verniciato bronzo. Parti metalliche in nero bronzato. Interruttore a pulsante touch posizionato sulla struttura.

Floor lamp with dimmable LED light. Mouth-blown and bronze painted glass. Bronzed black metal parts. Touch button switch positioned on the lamp structure

Le lampade DIANTHA TERRA sono fornite complete di lampadine come servizio di cortesia.

As courtesy DIANTHA TERRA lamps are supplied with light bulbs.



Cm
104,5 x 80 x 220

Inches
41¼" x 31½" x 87½"

[For technical drawing / p. 560](#)

[Pricelist 2023 / p. 178](#)

CRISTALLO/GLASS

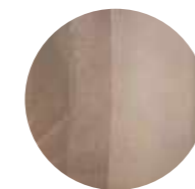

Cristallo soffiato a bocca
verniciato bronzo
Mouth blow bronze
painted glass

PARTI METALLICHE/ METAL PARTS

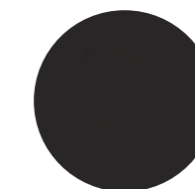

Nero bronzato
Bronzed black

INFORMAZIONI TECNICHE/ TECHNICAL INFORMATION

CTT: 2700K
CRI: ≥ 80
Light output: 800lm
Light sources: G4 12V 1,8W each
Dimmability: touch button
Cable lenght: 3mt





Epsilon

Massimo Castagna / 2016

Lampada a sospensione a luce a LED dimmerabile. Cilindri in cristallo sagomato a mano. Parti metalliche in ottone brunito a mano. L'altezza può essere realizzata a misura da un minimo di 115 cm ad un massimo di 450cm.

Hanging lamp with dimmable LED light. Handshaped glass cylinders. Hand burnished metal parts. The height can be customised from minimum of 115cm to a maximum of 450cm.

Le lampade EPSILON sono fornite complete di lampadine come servizio di cortesia.

As courtesy EPSILON lamps are supplied with light bulbs.

Composta da:

6 cilindri Ø3 x 29 cm / Ø1¼" x 11½"
6 cilindri Ø3 x 22 cm / Ø1¼" x 8¾"

Composed by:

6 cylinders Ø3 x 29 cm / Ø1¼" x 11½"
6 cylinders Ø3 x 22 cm / Ø1¼" x 8¾"

! **Versione 220-240V:** la lampada viene fornita con driver per dimmerazione in taglio di fase.
* **Versione 110V:** la lampada viene fornita con driver per dimmerazione 1-10V.

! **Version 220-240V:** the lamp is supplied with phase-cut driver.
Version 110V: the lamp is supplied with 1-10V driver.

In caso di presenza di un diverso sistema di dimmerazione o per connessione con sistema di domotica, si prega di specificare al momento dell'ordine per verificarne la compatibilità.

In case of need for different dimmer system or for the connection to home automation system, please inform us prior to ordering for checking compatibility.

NOTE TECNICHE SUI MATERIALI

OTTONE BRUNITO A MANO | L'ottone brunito a mano è ottenuto da un processo di ossidazione naturale eseguito manualmente. Il risultato di questa lavorazione è un prodotto che può presentare macchie e variazioni di colore che non sono da considerarsi imperfezioni ma caratteristiche che conferiscono ad ogni pezzo una particolare unicità, rendendolo esclusivo.

TECHNICAL INFORMATION ON THE MATERIALS

HAND BURNISHED BRASS | The hand burnished brass is the consequence of hand-made process of natural oxidation. The result of this processing is a product that may show marks and colour variations. These differences are inevitable and should not be considered imperfections but evidence of the hand-crafted process. They enhance the beauty and distinctiveness of a unique piece.



Cm
Ø 100 x 115
Ø 160 x 115

Inches
Ø 39½" x 45½"
Ø 63" x 45½"

For technical drawing / p. 560

Pricelist 2023 / p. 179
Homescapes, gentle attitude / pp. 92, 93

CILINDRI/ CYLINDERS



Cristallo sagomato a mano
Handshaped glass

**PARTI METALLICHE/
METAL PARTS**



Ottone brunito a mano
Hand burnished brass

**INFORMAZIONI TECNICHE/
TECHNICAL INFORMATIONS**

CTT: 2700K
CRI: ≥ 80
Light output: 2400lm
Light sources: G4 12V 1,8W each
Dimmability: phase-cut (220-240V), 1-10V (110V)
Weight: ≈15kg (Ø100cm), ≈26kg (Ø160cm)





Epsilon Sola

Massimo Castagna / 2017

Lampada a sospensione a luce LED integrata (non dimmerabile). Cilindri in cristallo trasparente sagomato a mano. Parti metalliche in ottone lucido, satinato, brunito a mano, cromato nero o ramato. Rosone in metallo nero bronzato. In dotazione cavo da 4mt per regolare l'altezza. Su richiesta realizzabili set da 3 e 5 lampade con un unico rosone. Questa versione è dimmerabile solo per voltaggio 220-240V.

Hanging lamp with integrated LED light (not dimmable). Handshaped transparent glass cylinders. Bright, satin, hand burnished, black chromed or coppered brass metal parts. Bronzed black metal canopy. Supplied with 4mt long cable to customize height. On request set of 3 or 5 lamps with unique canopy. This version is dimmable only for 220-240V.

Rosone unico set 3 pezzi:

2 cilindri Ø6 x 36 cm / Ø2½" x 14¼"
1 cilindro Ø8 x 46 cm / Ø3¼" x 18¼"

Rosone unico set 5 pezzi:

3 cilindri Ø6 x 36 cm / Ø2½" x 14¼"
2 cilindro Ø8 x 46 cm / Ø3¼" x 18¼"

Unique canopy

set of 3 pcs:

2 cylinders Ø6 x 36 cm / Ø2½" x 14¼"
1 cylinder Ø8 x 46 cm / Ø3¼" x 18¼"

Unique canopy

set of 5 pcs:

3 cylinders Ø6 x 36 cm / Ø2½" x 14¼"
2 cylinders Ø8 x 46 cm / Ø3¼" x 18¼"

! La composizione da 3 e 5 lampade con un unico rosone è dimmerabile solo per voltaggio 220-240V. Questa versione viene fornita con driver per dimmerazione in taglio di fase.

In caso di presenza di un diverso sistema di dimmerazione o per connessione con sistema di domotica, si prega di specificare al momento dell'ordine per verificarne la compatibilità.

! The composition of 3 or 5 lamps with unique canopy is dimmable only for 220-240V voltage. This version is supplied with phase-cut driver.

In case of need for different dimmer system or for the connection to home automation system, please inform us prior to ordering for checking compatibility.

NOTE TECNICHE SUI MATERIALI

OTTONE BRUNITO A MANO | L'ottone brunito a mano è ottenuto da un processo di ossidazione naturale eseguito manualmente. Il risultato di questa lavorazione è un prodotto che può presentare macchie e variazioni di colore che non sono da considerarsi imperfezioni ma caratteristiche che conferiscono ad ogni pezzo una particolare unicità, rendendolo esclusivo.

TECHNICAL INFORMATION ON THE MATERIALS

HAND BURNISHED BRASS | The hand burnished brass is the consequence of hand-made process of natural oxidation. The result of this processing is a product that may show marks and colour variations. These differences are inevitable and should not be considered imperfections but evidence of the hand-crafted process. They enhance the beauty and distinctiveness of a unique piece.

	Cm	Inches
S	Ø 6 x 36	Ø 2½" x 14¼"
L	Ø 8 x 46	Ø 3¼" x 18¼"



For technical drawing / p. 560

Pricelist 2023 / p. 180
Homescapes, intimate portraits / p. 52
Homescapes, gentle attitude / pp. 52, 55

CILINDRI/ CYLINDERS



Cristallo sagomato a mano
Handshaped glass

ROSONE/ CANOPY

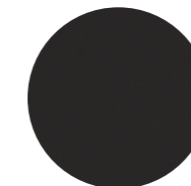

Nero bronzato
Bronzed black

PARTI METALLICHE/ METAL PARTS

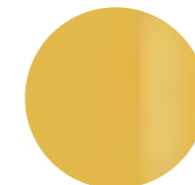

Ottone lucido
Bright brass

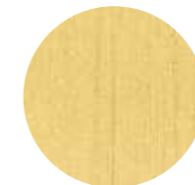

Ottone satinato
Satin brass



Ottone brunito a mano
Hand burnished brass

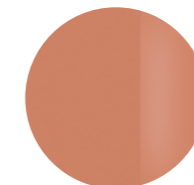

Ottone ramato
Coppered brass



Cromo nero
Black chrome

INFORMAZIONI TECNICHE/ TECHNICAL INFORMATIONS

CTT: 2700K
CRI: ≥ 80
Light output: 357lm
Light sources: LED spot 3,15W 350mA (constant current)
Dimmability: NO - Dimmable phase-cut just for 3-5 lamps version (only for 220-240V)
Cable length: 4mt
Weight: ≈3kg



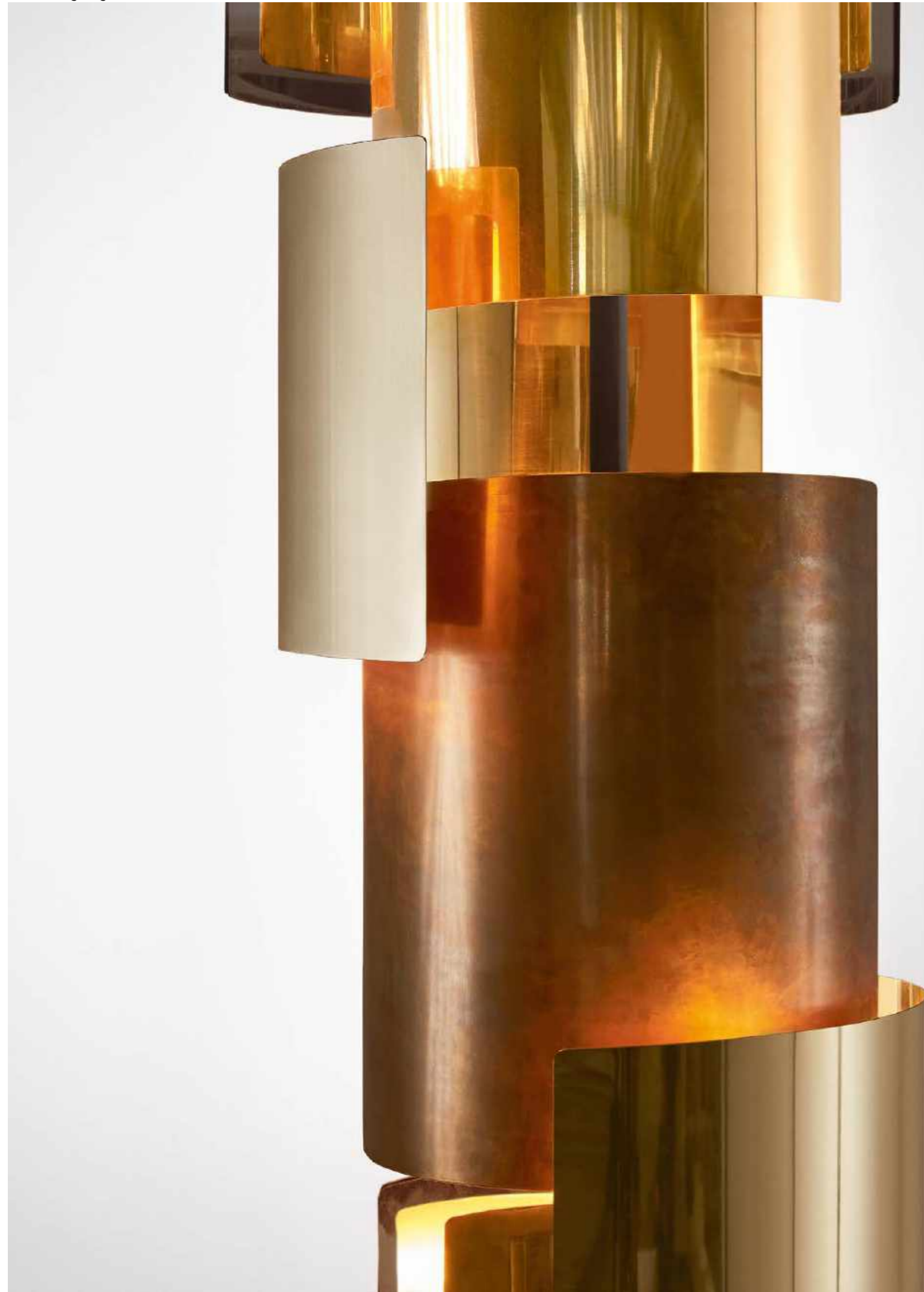

Eris

Massimo Castagna / 2017

Lampada a sospensione a luce LED non dimmerabile con struttura verniciata nero bronzato e fasce in ottone lucido, satinato, brunito a mano e cromo nero.

Hanging lamp with LED light (not dimmable) with black bronzed painted structure and bright, satin, hand-burnished and black chromed brass parts.

NOTE TECNICHE SUI MATERIALI

OTTONE BRUNITO A MANO | L'ottone brunito a mano è ottenuto da un processo di ossidazione naturale eseguito manualmente. Il risultato di questa lavorazione è un prodotto che può presentare macchie e variazioni di colore che non sono da considerarsi imperfezioni ma caratteristiche che conferiscono ad ogni pezzo una particolare unicità, rendendolo esclusivo.

TECHNICAL INFORMATION ON THE MATERIALS

HAND BURNISHED BRASS | The hand burnished brass is the consequence of hand-made process of natural oxidation. The result of this processing is a product that may show marks and colour variations. These differences are inevitable and should not be considered imperfections but evidence of the hand-crafted process. They enhance the beauty and distinctiveness of a unique piece.



Cm

Ø 35 x 180
Ø 35 x 210
Ø 35 x 250
Ø 35 x 280
Ø 35 x 320

Inches

Ø 14" x 71"
Ø 14" x 82¾"
Ø 14" x 98½"
Ø 14" x 110¼"
Ø 14" x 126"

[For technical drawing / p. 56](#)

[Pricelist 2023 / p. 181](#)
[Homescapes, sense of materials / p. 18](#)

STRUTTURA/STRUCTURE

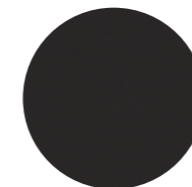

Nero bronzato
Black bronzed

FASCE/PARTS

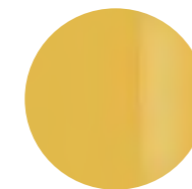

Ottone lucido
Bright brass

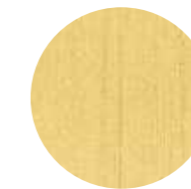

Ottone satinato
Satin brass



Ottone brunito a mano
Hand burnished brass

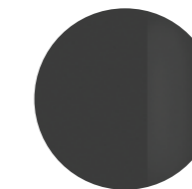

Cromo nero
Black chrome

INFORMAZIONI TECNICHE/ TECHNICAL INFORMATIONS

CTT: 3000K
CRI: ≥ 80
Light output: 4680lm
Light sources: LED stripe/integrated: 57,6W (19,2W/mt x 3mt), 1560lm/mt x3
Dimmability: NO
Weight: ≈30kg





Jolie

Federica Biasi / 2019

Lampada a sospensione a luce LED dimmerabile composta da due calotte in vetro di Murano soffiato a bocca. Dettagli metallici in ottone satinato. Disponibile anche versione con dettagli metallici in ottone brunito scuro. In dotazione cavo da 4 mt per regolare l'altezza.

NOTE TECNICHE SUI MATERIALI

VETRO DI MURANO | Eventuali piccole bolle e segni presenti sulla superficie sono dovuti alle lavorazioni del vetro, da non considerarsi difetti.

! La lampada viene fornita con driver per dimmerazione 1-10V.

In caso di presenza di un diverso sistema di dimmerazione o per connessione con sistema di domotica, si prega di specificare al momento dell'ordine per verificarne la compatibilità.

Hanging lamp with dimmable LED light composed by two dome shaped sections in Murano's mouth-blown glass. Satin brass metal details. Also available version with dark burnished brass metal details. Supplied with cable 4mt long to customize height.

TECHNICAL INFORMATION ON THE MATERIALS

MURANO'S GLASS | Any small bubbles and marks present on the surface are due to the production of this type of glass and are therefore not to be considered defects.

! The lamp is supplied with 1-10V driver.

In case of need for different dimmer system or for the connection to home automation system, please inform us prior to ordering for checking compatibility.



Cm
Ø 60 x 62

Inches
Ø 23¾" x 24½"

[For technical drawing / p. 56](#)

Pricelist 2023 / p. 182
Homescapes, sense of materials / p. 18
Homescapes, gentle attitude / pp. 28, 30

VETRO/GLASS



Vetro di Murano
soffiato a bocca
Murano's mouth-blown
glass

DETTAGLI/DETAILS



Ottone satinato
Satin brass

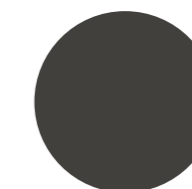

Ottone brunito scuro
Dark burnished brass

INFORMAZIONI TECNICHE/ TECHNICAL INFORMATIONS

CTT: 3200K
CRI: ≥ 90
Light output: 1800lm
Light sources: LED module 15W
Dimmability: 1-10V
Cable length: 4mt
Weight: ≈15kg





Jolie Applique

Federica Biasi / 2019

Applique in cristallo soffiato a bocca. Dettagli metallici in ottone satinato. Luce LED (non dimmerabile). Disponibile anche versione con dettagli metallici in ottone brunito scuro.

Wall light in mouth-blown glass. Satin brass metal details. LED light (not dimmable). Also available version with dark burnished brass metal details.

NOTE TECNICHE SUI MATERIALI

VETRO SOFFIATO A BOCCA | Eventuali piccole bolle e segni presenti sulla superficie sono dovuti alle lavorazioni del vetro, da non considerarsi difetti.

TECHNICAL INFORMATION ON THE MATERIALS

MOUTH_BLOWN GLASS | Any small bubbles and marks present on the surface are due to the production of this type of glass and are therefore not to be considered defects.



Cm
 Ø 20 x 11
 Ø 30 x 15

Inches
 Ø 8" x 4½"
 Ø 12" x 6"

[For technical drawing / p. 56](#)

Pricelist 2023 / p. 183
 Homescapes, sense of materials / p. 74
 Homescapes, gentle attitude / pp. 16, 17, 28, 29

VETRO/GLASS



Cristallo soffiato a bocca
 Mouth-blown glass

DETTAGLI/DETAILS

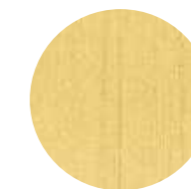

Ottone satinato
 Satin brass

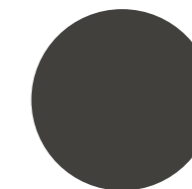

Ottone brunito scuro
 Dark burnished brass

INFORMAZIONI TECNICHE/ TECHNICAL INFORMATIONS

CTT: 3000K
 CRI: ≥ 80
 Light output: 1000lm
 Light sources: LED module 7,8W
 Dimmability: NO





Key-to-Heaven

Massimo Castagna / 2022

Lampada a sospensione a luce LED (non dimmerabile). Parti metalliche in ottone satinato oppure brunito scuro. In dotazione cavo di 4mt per regolare l'altezza.

Hanging lamp with LED light (not dimmable). Satin or dark burnished brass metal parts. Supplied with cable 4mt long to customize height.

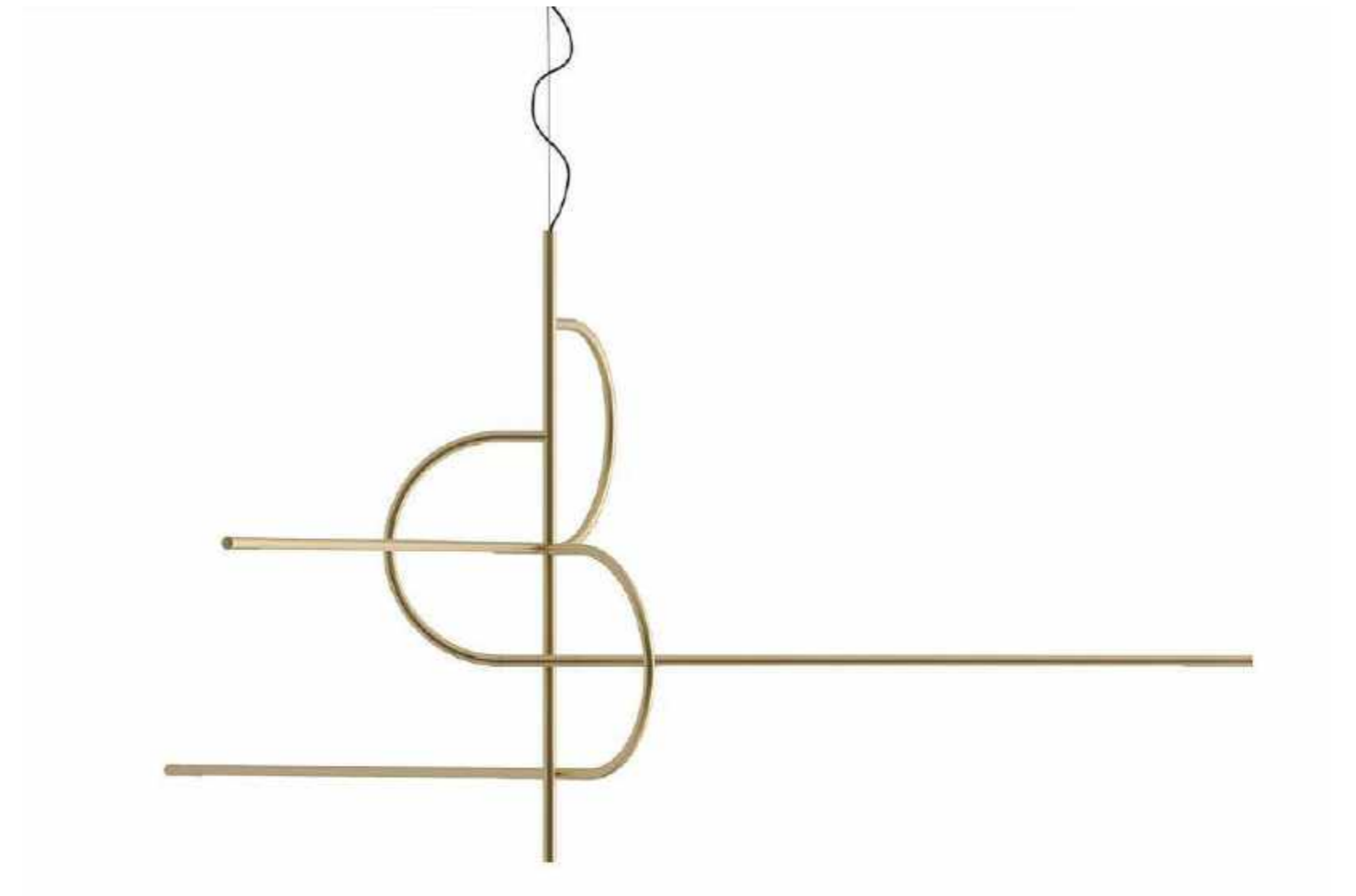

Cm
233 x 204 x 120

Inches
9 1/4" x 80 1/2" x 47 1/4"

For technical drawing / p. 562

Pricelist 2023 / p. 184
Homescapes, gentle attitude / pp. 72, 73, 76, 77

**PARTI METALLICHE/
METAL PARTS**

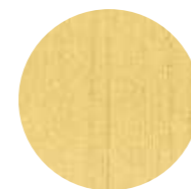

Ottone satinato
Satin brass

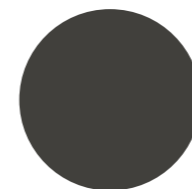

Ottone brunito scuro
Dark burnished brass

**INFORMAZIONI TECNICHE/
TECHNICAL INFORMATION**

CTT: 2700K
CRI: ≥ 80
Light output: 1081lm
Light sources: LED stripe/integrated: 11,5W
Dimmability: NO





Key-to-Heaven Fix

Massimo Castagna/2022

Lampada a sospensione a luce LED (non dimmerabile). Struttura a 4 vie in ottone brunito scuro. Disponibile in 3 altezze predefinite.

Hanging lamp with LED light (not dimmable). Dark burnished metal structure with 4 arms. Available in three standard heights.



Cm

158 x 79 x 115
158 x 79 x 145
158 x 79 x 175

Inches

62¼" x 31¼" x 45½"
62¼" x 31¼" x 57¼"
62¼" x 31¼" x 69"

For technical drawing / p. 562

Pricelist 2023 / p. 185
Homescapes, gentle attitude / pp. 72, 73, 76, 77

STRUTTURA/STRUCTURE

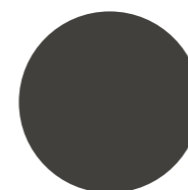

Ottone brunito scuro
Dark burnished brass

INFORMAZIONI TECNICHE/ TECHNICAL INFORMATION

CTT: 2700K
CRI: ≥ 80
Light output: 1081lm
Light sources: LED stripe/integrated: 11,5W
Dimmability: NO





Narghilé

Massimo Castagna / 2018

Lampada a sospensione a luce LED non dimmerabile. Cilindri in cristallo trasparente sagomato a mano. Parti metalliche in ottone cromato lucido. Rosone in metallo verniciato bianco. In dotazione cavo di 4mt per regolare l'altezza. Su richiesta set da 4 e 6 lampade con un unico rosone. Questa versione è dimmerabile solo per voltaggio 220-240V.

! Disponibile fino ad esaurimento scorte.

La composizione da 4 e 6 lampade con un unico rosone è dimmerabile solo per voltaggio 220-240V. Questa versione viene fornita con driver per dimmerazione in taglio di fase.

In caso di presenza di un diverso sistema di dimmerazione o per connessione con sistema di domotica, si prega di specificare al momento dell'ordine per verificarne la compatibilità.

Hanging lamp with LED light (not dimmable). Handshaped transparent glass cylinders. Bright chromed brass metal parts. White painted metal canopy. Supplied with cable 4mt long to customize height. On request set of 4 or 6 lamps with unique canopy. This version is dimmable only for 220-240V voltage.

! Available while stock lasts.

The composition of 4 or 6 lamps with unique canopy is dimmable only for 220-240V voltage. This version is supplied with phase-cut driver.

In case of need for different dimmer system or for the connection to home automation system, please inform us prior to ordering for checking compatibility.



Cm

Ø 30 x 79

Ø 30 x 98

Rosone

36 x 36 x 4 | singola

72 x 72 x 4 | 4 pezzi

72 x 108 x 4 | 6 pezzi

Inches

Ø 12" x 31¼"

Ø 12" x 38¾"

Canopy

14¼" x 14¼" x 1¼" | single

28½" x 28½" x 1¼" | 4 pieces

28½" x 42¾" x 1¼" | 6 pieces

[For technical drawing / p. 563](#)

[Pricelist 2023 / p. 186](#)

[Homescapes, sense of materials / p. 51](#)

[Homescapes, gentle attitude / pp. 98, 99](#)

CILINDRI/ CYLINDERS



Cristallo sagomato a mano
Handshaped glass

PARTI METALLICHE/ METAL PARTS



Ottone cromato lucido
Chromed brass

ROSONE/CANOPY



Metallo verniciato bianco
White painted metal

INFORMAZIONI TECNICHE/ TECHNICAL INFORMATION

CTT: 2700K

CRI: ≥ 80

Light output: 357lm

Light sources: LED spot 3,15W 350mA (costant current)

Dimmability: NO - Dimmable phase-cut just for 4-6 lamps version (only for 220-240V)

Cable length: 4mt

Weight: ≈40kg





Ori

Massimo Castagna / 2017

Applique in ottone satinato all'esterno e lucido all'interno.
Disponibile anche nella versione in ottone brunito a mano "dark" all'esterno e ottone lucido all'interno.
Lampada a LED non dimmerabile.

Wall lamp in satin brass outside and bright brass inside.
Also available in the version in "dark" hand burnished brass outside and bright brass inside.
LED light (not dimmable).



Cm
18 x 5 x 48

Inches
7 1/4" x 2" x 19"

[For technical drawing / p. 563](#)

[Pricelist 2023 / p. 187](#)
[Homescapes, intimate portraits / p. 82](#)

**STRUTTURA ESTERNA/
OUTSIDE STRUCTURE**

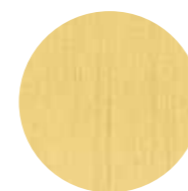

Ottone satinato
Satin brass



Ottone brunito a
mano "dark"
"Dark" hand burnished brass

**STRUTTURA INTERNA/
INSIDE STRUCTURE**



Ottone lucido
Bright brass

**INFORMAZIONI TECNICHE/
TECHNICAL INFORMATION**

CTT: 4000K
CRI: ≥ 80
Light output: 1500lm
Light sources: LED stripe/integrated: 2x5W 24Vdc
Dimmability: NO
Weight: ≈7kg



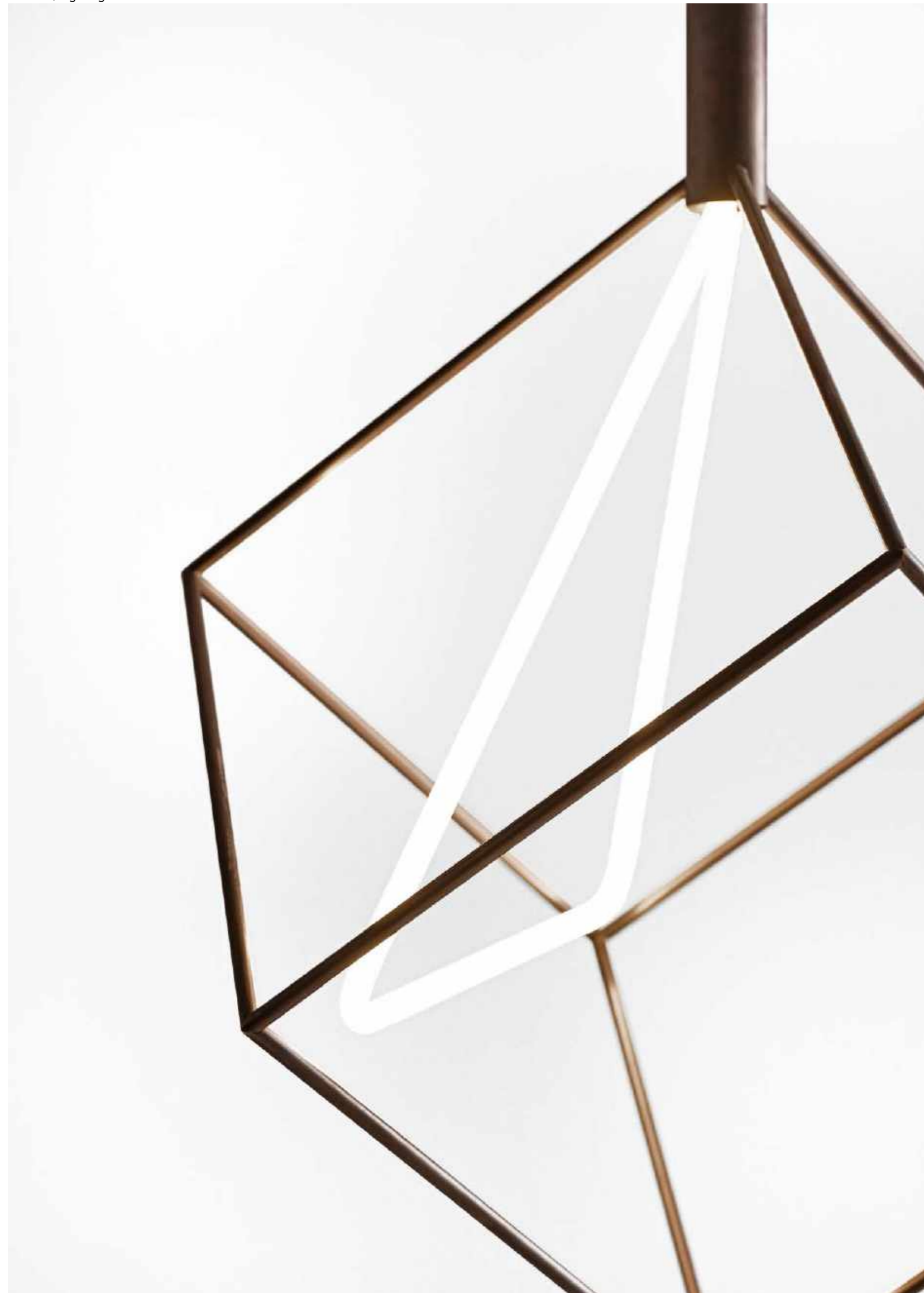

Spectrum

Studiopepe / 2021

Lampada a sospensione a luce NEON dimmerabile solo nella versione 220/240V. Fonte luminosa in Neon curvato a caldo. Struttura in ottone brunito a mano. In dotazione cavo da 4mt per regolare l'altezza. Disponibile in due dimensioni e due diverse configurazioni del NEON.

! La lampada è dimmerabile solo per voltaggio 220-240V. Questa versione viene fornita con driver per dimmerazione in taglio di fase.

In caso di presenza di un diverso sistema di dimmerazione o per connessione con sistema di domotica, si prega di specificare al momento dell'ordine per verificarne la compatibilità.

NOTE TECNICHE SUI MATERIALI

OTTONE BRUNITO A MANO | L'ottone brunito a mano è ottenuto da un processo di ossidazione naturale eseguito manualmente. Il risultato di questa lavorazione è un prodotto che può presentare macchie e variazioni di colore che non sono da considerarsi imperfezioni ma caratteristiche che conferiscono ad ogni pezzo una particolare unicità, rendendolo esclusivo.

Hanging lamp with NEON light, dimmable just for version 220/240V. Light source in hotbent NEON. Hand burnished brass structure. Supplied with cable 4 meters long to customize height. Available in two dimensions and two different configurations of the NEON.

! The lamp is dimmable only for 220-240V voltage. This version is supplied with phase-cut driver.

In case of need for different dimmer system or for the connection to home automation system, please inform us prior to ordering for checking compatibility.

TECHNICAL INFORMATION ON THE MATERIALS

HAND BURNISHED BRASS | The hand burnished brass is the consequence of hand-made process of natural oxidation. The result of this processing is a product that may show marks and colour variations. These differences are inevitable and should not be considered imperfections but evidence of the hand-crafted process. They enhance the beauty and distinctiveness of a unique piece.

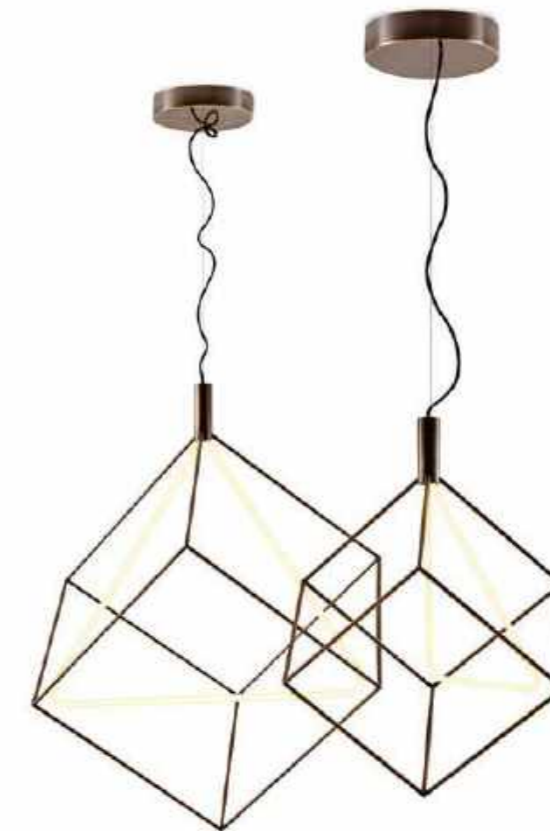

	Cm	Inches
A	64,5 x 56 x 79	25½" x 22¼" x 31¼"
	97,5 x 84,5 x 114	38½" x 33½" x 45"
B	64,5 x 56 x 79	25½" x 22¼" x 31¼"
	97,5 x 84,5 x 114	38½" x 33½" x 45"

[For technical drawing / p. 564](#)

[Pricelist 2023 / p. 188](#)
[Homescapes, intimate portraits / p. 28](#)
[Homescapes, gentle attitude / pp. 24, 25, 90](#)

STRUTTURA/STRUCTURE



Ottone brunito a mano
Hand burnished brass

INFORMAZIONI TECNICHE/ TECHNICAL INFORMATIONS

CTT: 2800K
 CRI: ≥ 80
 Light output: 1680lm (79h version) 3410lm (114h version)
 Light sources:
 hot-bent NEON 22W, 1,4mt Ø15mm(79h version)
 hot-bent NEON 39W, 2,2mt Ø18mm(114h version)
 Dimmability: phase-cut (only for 220-240V)
 Cable length: 4mt
 Weight: ≈20kg (79h version), ≈22kg (114h version)



14

Lampade / Lightings
TECHNICAL MODULE

GENERAL INDICATION

220-240V EU - UK	CCT (K)	CRI	Light output (lm)	Light sources	Dimmability
Bolle	2700K	≥ 80	800lm 1200lm	n.4 G4 12V 1,8W each (7,2W totally) n.6 G4 12V 1,8W each (10,8W totally)	phase-cut
Bolle Aria	2700K	≥ 80	600lm	n.3 G4 12V 1,8W each (5,4W)	phase-cut
Bolle Cielo	2700K	≥ 80	1200lm 1800lm	n.6 G4 12V 1,8W each (10,8W totally) n.9 G4 12V 1,8W each (16,2W totally)	phase-cut
Bolle Orizzontale	2700K	≥ 80	2000lm 3200lm	n.10 G4 12V 1,8W each (18W totally) n.16 G4 12V 1,8W each (28,8W totally)	1 - 10 V
Bolle Sola	2700K	≥ 80	200lm	n.1 G4 12V 1,8W each	1 lamp version: NO 3/5 lamps version: phase-cut
Bolle Tavolo 1	2700K	≥ 80	200lm	n.1 G4 12V 1,8W each	NO
Bolle Tavolo 3	2700K	≥ 80	600lm	n.3 G4 12V 1,8W each (5,4W)	YES
Bolle Tela	2700K	≥ 80	1200lm 1600lm	n.6 G4 12V 1,8W each (10,8W totally) n.8 G4 12V 1,8W each (14,4W totally)	1 - 10 V
Bolle Terra	2700K	≥ 80	800lm	n.4 G4 12V 1,8W each (7,2W totally)	YES
Bolle Verticale	2700K	≥ 80	700lm	n.7 G4 12V 1W each (7W totally)	YES
Bonfire	3000K	≥ 80	595lm	LED module 5,8W 500mA	YES
Diantha	2700K	≥ 80	1200lm	n.6 G4 12V 1,8W each (10,8W totally)	phase-cut
Diantha Terra	2700K	≥ 80	800lm	n.4 G4 12V 1,8W each (7,2W totally)	YES
Epsilon	2700K	≥ 80	2400lm	n.12 G4 12V 1,8W each (21,6W totally)	phase-cut
Epsilon Sola	2700K	≥ 80	357lm	LED Spot: 3,15W 350mA (constant current)	1 lamp version: NO 3/5 lamps version: phase-cut
Eris	3000K	≥ 80	4680lm	LED Stripe/integrated: 57,6W (19,2W/ mt x 3mt) (1560lm/mt x 3)	NO
Jolie	3200K	≥ 90	1800lm	LED module 15W	1 - 10 V
Jolie Applique	3000K	≥ 80	1000lm	LED module 7,8W	NO
Key-to-Heaven	2700K	≥ 80	1081lm	LED Stripe/integrated: 11,5W	NO
Key-to-Heaven Fix	2700K	≥ 80	1081lm	LED Stripe/integrated: 11,5W	NO
Narghilè	2700K	≥ 80	357lm	LED Spot: 3,15W 350mA (constant current)	1 lamp version: NO 4/6 lamps version: phase-cut
Ori	4000K	≥ 80	1500lm	LED Stripe/integrated: 2x5W 24Vdc	NO
Spectrum	2800K	≥ 80	3410lm 1680lm	39W (2,2 mt, Ø18 mm) 22W (1,4 mt, Ø15 mm)	phase-cut

GENERAL INDICATION

110V USA	CCT (K)	CRI	Light output (lm)	Light sources	Dimmability
Bolle	2700K	≥ 80	800lm 1200lm	n.4 G4 12V 1,8W each (7,2W totally) n.6 G4 12V 1,8W each (10,8W totally)	1 - 10 V
Bolle Aria	2700K	≥ 80	600lm	n.3 G4 12V 1,8W each (5,4W)	1 - 10 V
Bolle Cielo	2700K	≥ 80	1200lm 1800lm	n.6 G4 12V 1,8W each (10,8W totally) n.9 G4 12V 1,8W each (16,2W totally)	1 - 10 V
Bolle Orizzontale	2700K	≥ 80	2000lm 3200lm	n.10 G4 12V 1,8W each (18W totally) n.16 G4 12V 1,8W each (28,8W totally)	1 - 10 V
Bolle Sola	2700K	≥ 80	200lm	n.1 G4 12V 1,8W each	NO
Bolle Tavolo 1	2700K	≥ 80	200lm	n.1 G4 12V 1,8W each	NO
Bolle Tavolo 3	2700K	≥ 80	600lm	n.3 G4 12V 1,8W each (5,4W)	YES
Bolle Tela	2700K	≥ 80	1200lm 1600lm	n.6 G4 12V 1,8W each (10,8W totally) n.8 G4 12V 1,8W each (14,4W totally)	1 - 10 V
Bolle Terra	2700K	≥ 80	800lm	n.4 G4 12V 1,8W each (7,2W totally)	YES
Bolle Verticale	2700K	≥ 80	700lm	n.7 G4 12V 1W each (7W totally)	YES
Bonfire	3000K	≥ 80	595lm	LED module 5,8W 500mA	YES
Diantha	2700K	≥ 80	1200lm	n.6 G4 12V 1,8W each (10,8W totally)	1 - 10 V
Diantha Terra	2700K	≥ 80	800lm	n.4 G4 12V 1,8W each (7,2W totally)	1 - 10 V
Epsilon	2700K	≥ 80	2400lm	n.12 G4 12V 1,8W each (21,6W totally)	1 - 10 V
Epsilon Sola	2700K	≥ 80	357lm	LED Spot: 3,15W 350mA (constant current)	NO
Eris	3000K	≥ 80	4680lm	LED Stripe/integrated: 57,6W (19,2W/ mt x 3mt) (1560lm/mt x 3)	NO
Jolie	3200K	≥ 90	1800lm	LED module 15W	1 - 10 V
Jolie Applique	3000K	≥ 80	1000lm	LED module 7,8W	NO
Key-to-Heaven	2700K	≥ 80	1081lm	LED Stripe/integrated: 11,5W	NO
Key-to-Heaven Fix	2700K	≥ 80	1081lm	LED Stripe/integrated: 11,5W	NO
Narghilè	2700K	≥ 80	357lm	LED Spot: 3,15W 350mA (constant current)	NO
Ori	4000K	≥ 80	1500lm	LED Stripe/integrated: 2x5W 24Vdc	NO
Spectrum	2800K	≥ 80	3410lm 1680lm	39W (2,2 mt, Ø18 mm) 22W (1,4 mt, Ø15 mm)	NO

Bolle | Massimo Castagna, 2015

Product information / p. 506

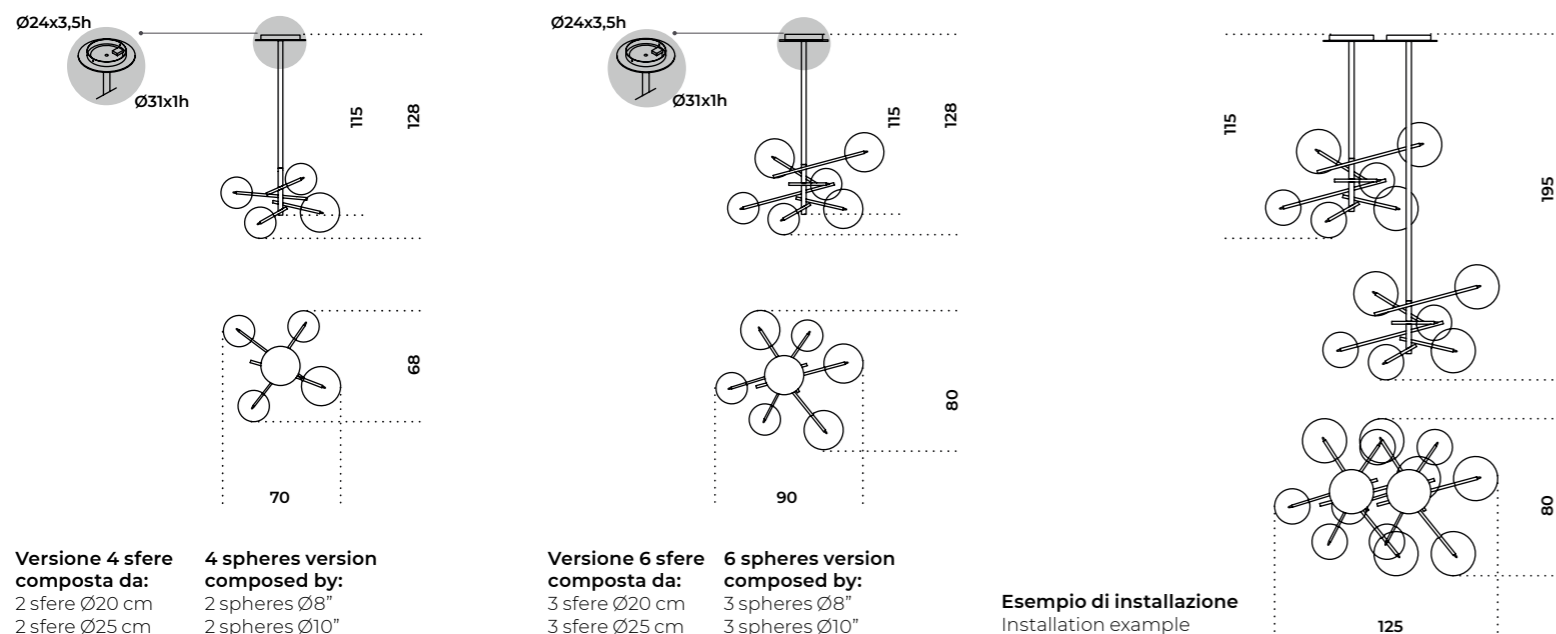

Bolle Orizzontale | Massimo Castagna, 2019

Product information / p. 512

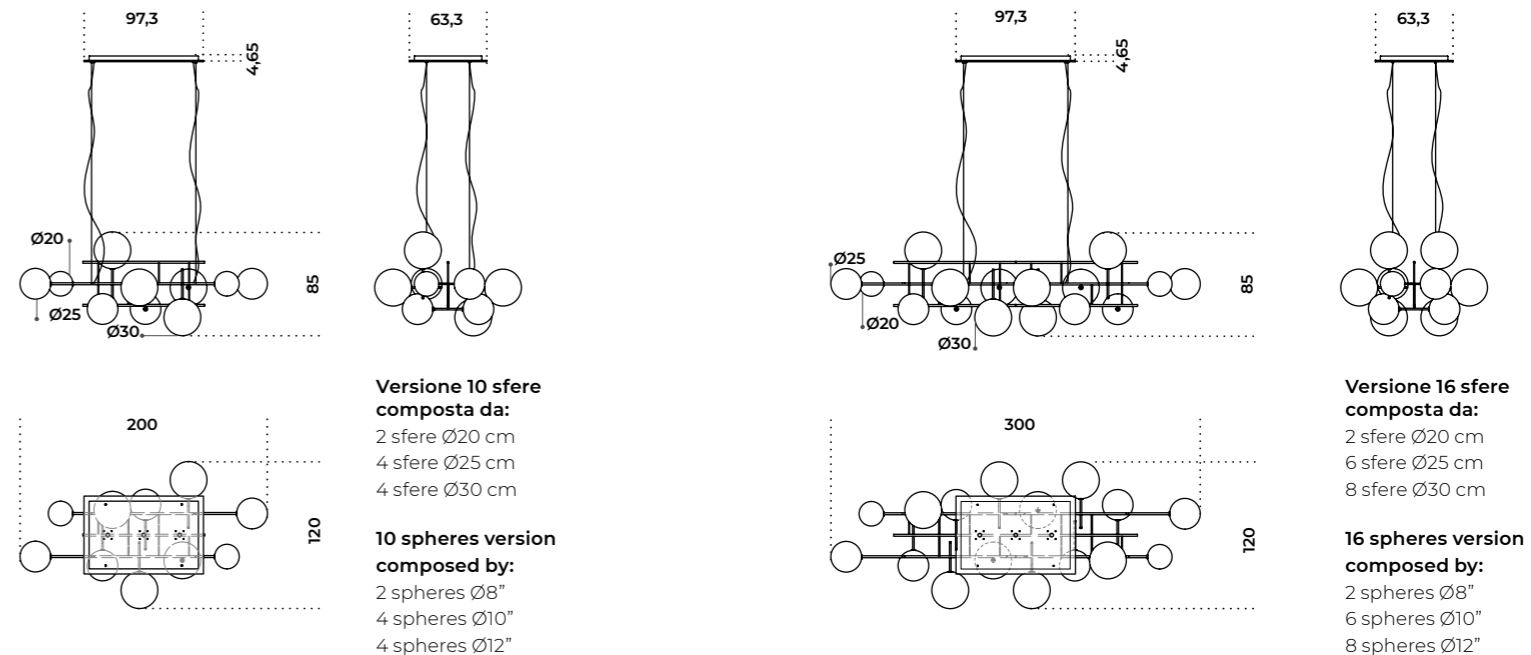

Bolle Aria | Massimo Castagna, 2020

Product information / p. 508

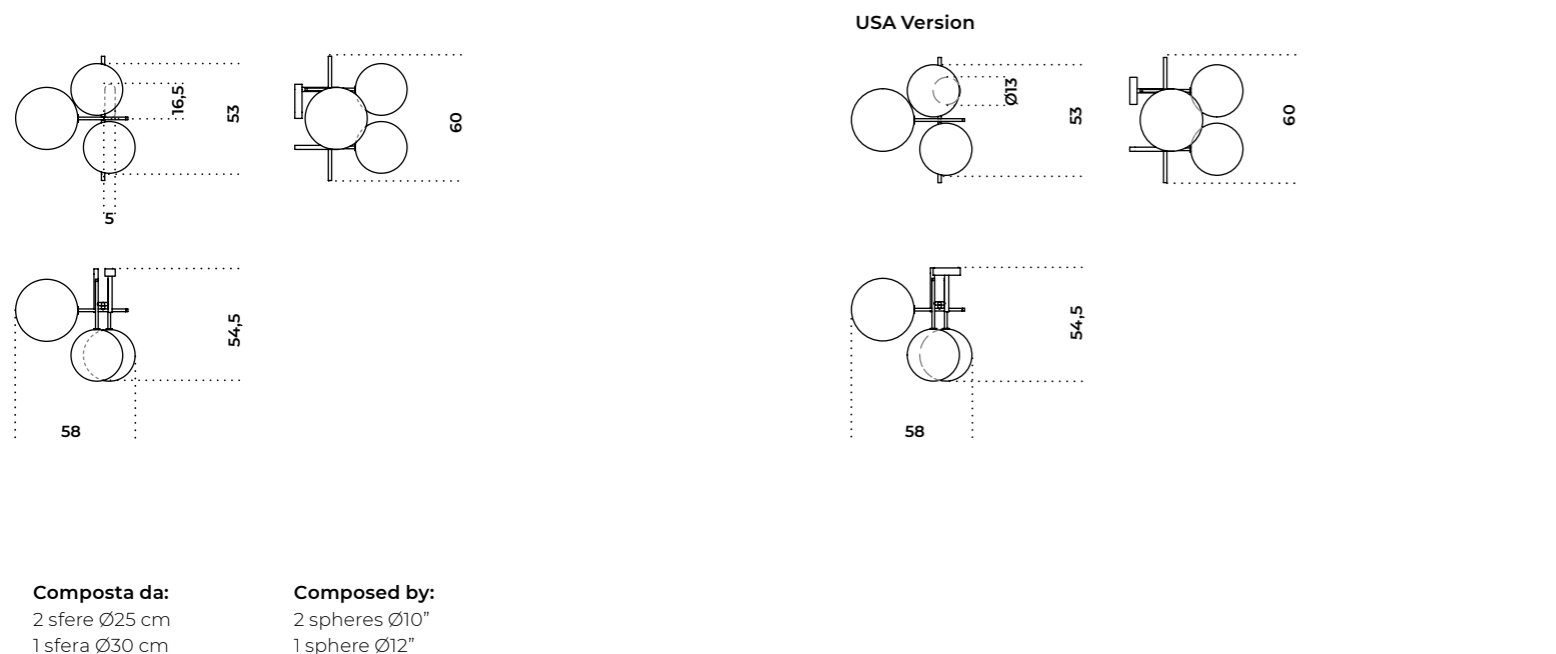

Bolle Sola | Massimo Castagna, 2019

Product information / p. 514

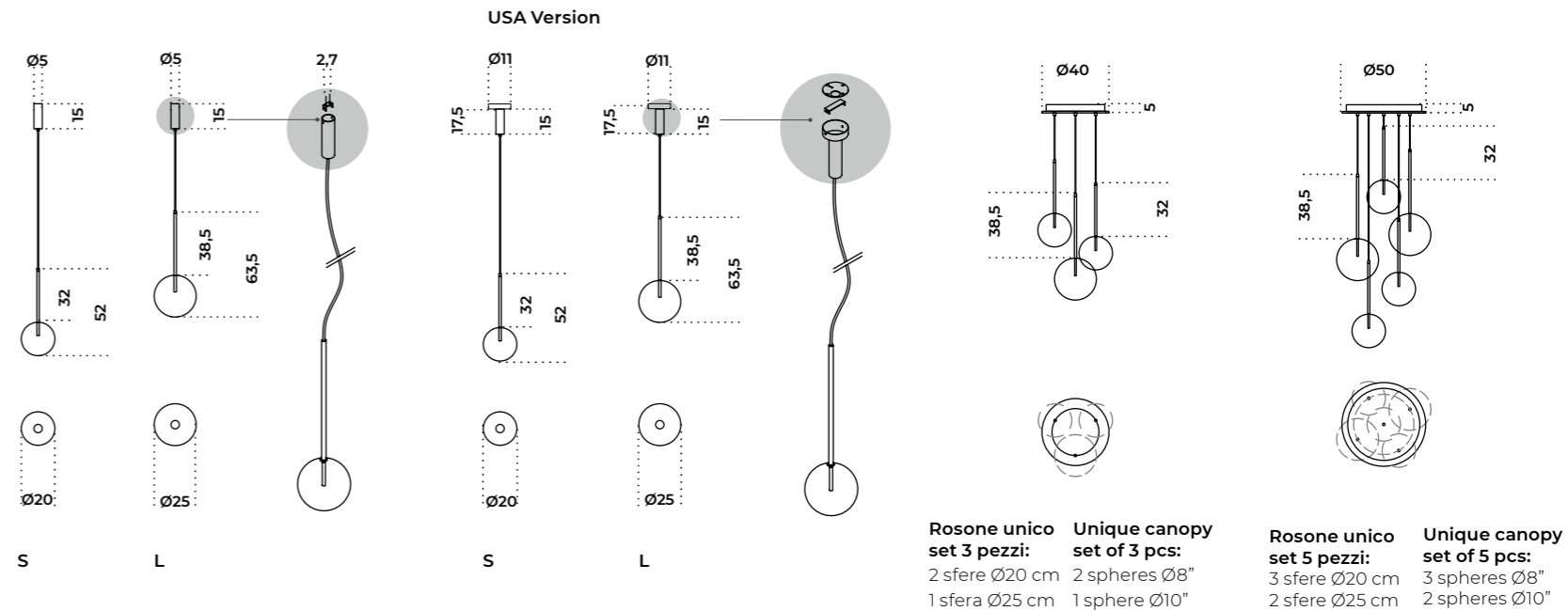

Bolle Cielo | Massimo Castagna, 2020

Product information / p. 510

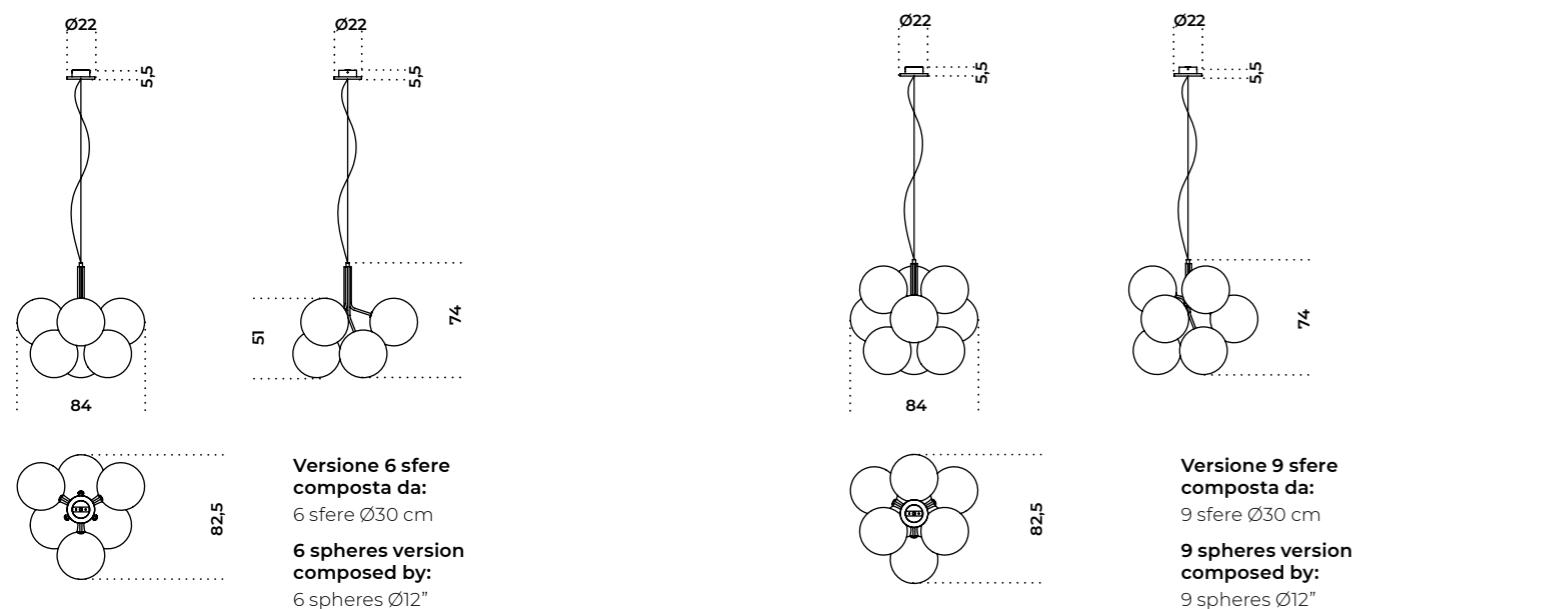

Bolle Tavolo 1 | Massimo Castagna, 2015

Product information / p. 516

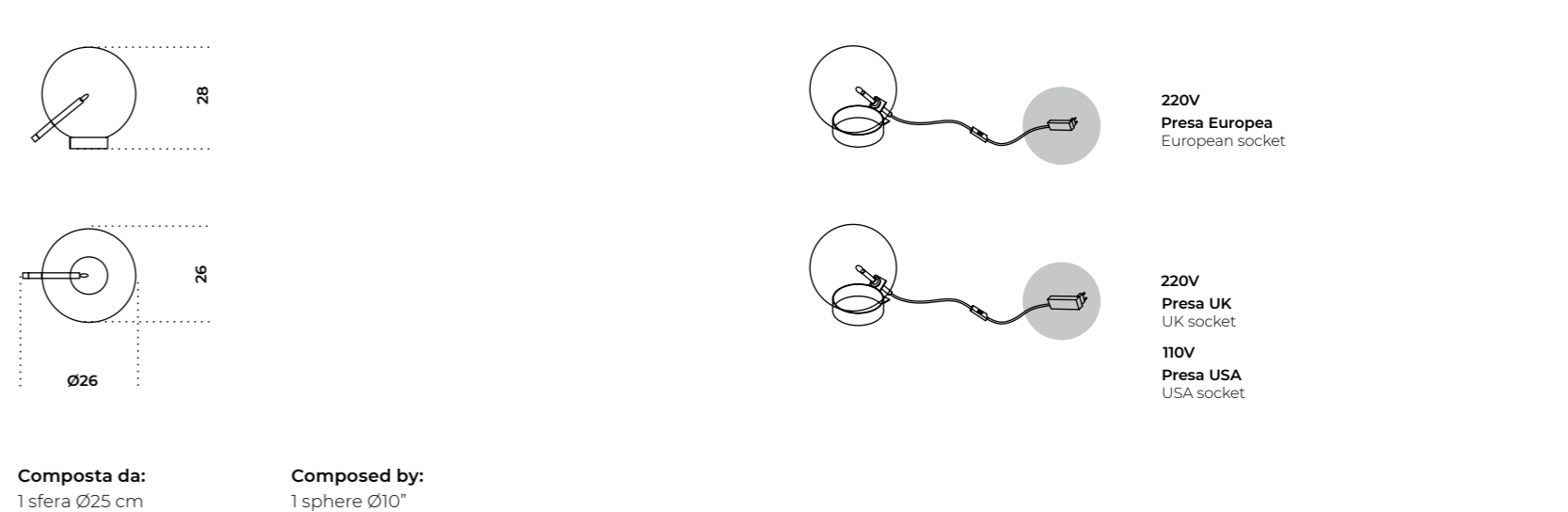

Bolle Tavolo 3 | Massimo Castagna, 2015

Product information / p. 518

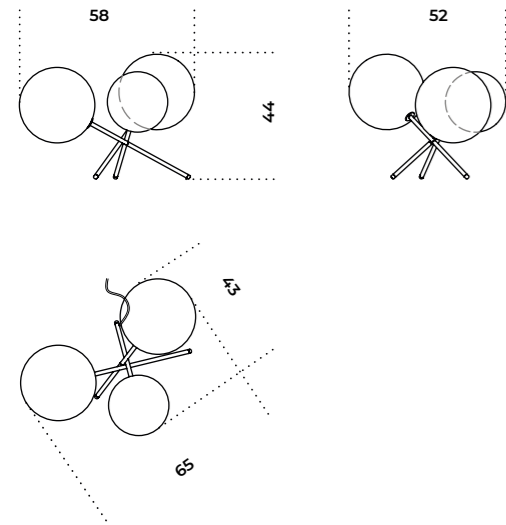

Composta da:
1 sfera Ø20 cm
2 sfere Ø25 cm

Composed by:
1 sphere Ø8"
2 spheres Ø10"

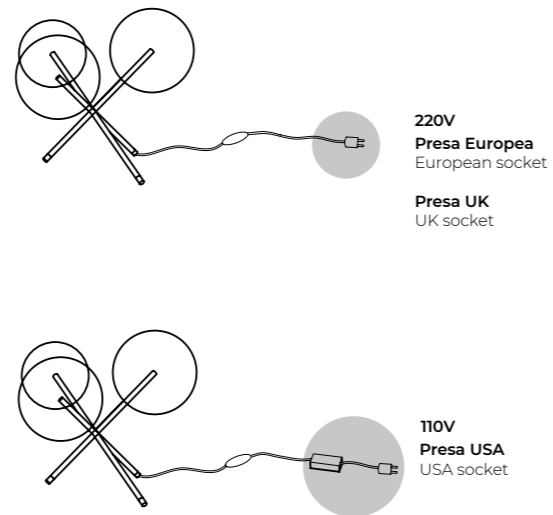

Bolle Verticale | Massimo Castagna, 2022

Product information / p. 524

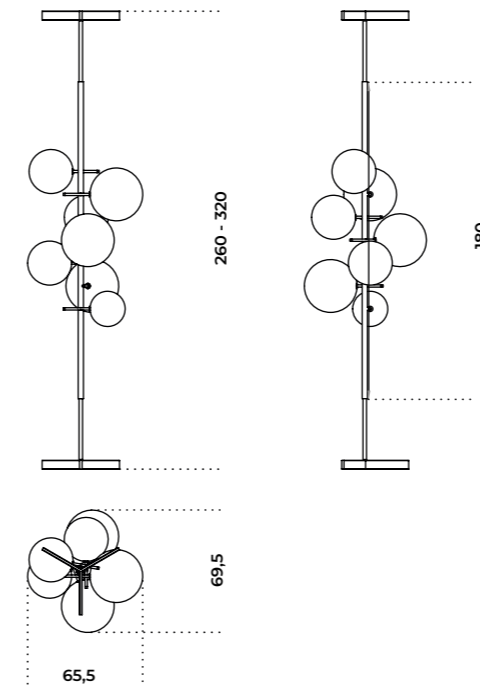

Bolle Tela | Massimo Castagna, 2018

Product information / p. 520

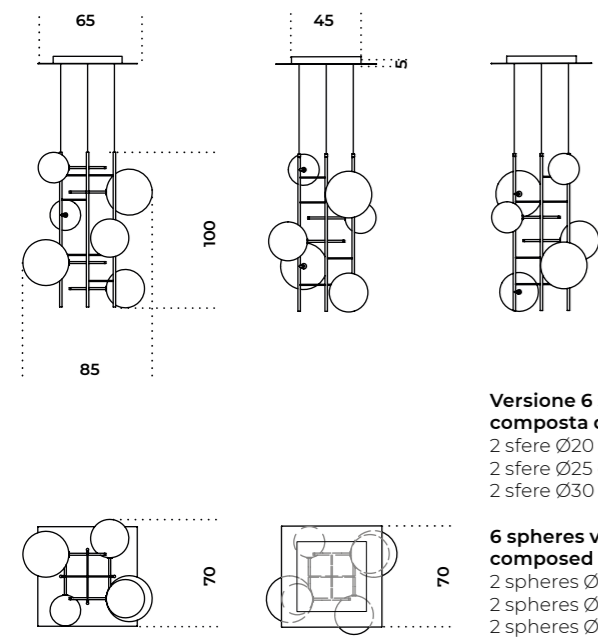

**Versione 6 sfere
composta da:**
2 sfere Ø20 cm
2 sfere Ø25 cm
2 sfere Ø30 cm

**6 spheres version
composed by:**
2 spheres Ø8"
2 spheres Ø10"
2 spheres Ø12"

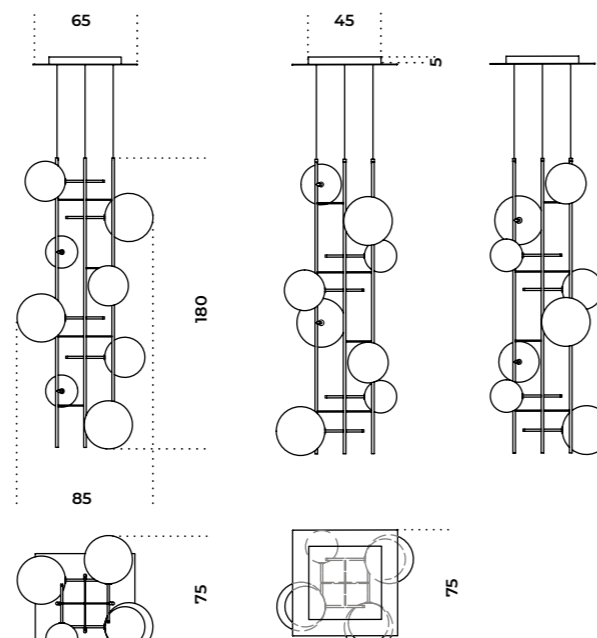

**Versione 8 sfere
composta da:**
2 sfere Ø20 cm
3 sfere Ø25 cm
3 sfere Ø30 cm

**8 spheres version
composed by:**
2 spheres Ø8"
3 spheres Ø10"
3 spheres Ø12"

Bonfire | Studiopepe, 2020

Product information / p. 526

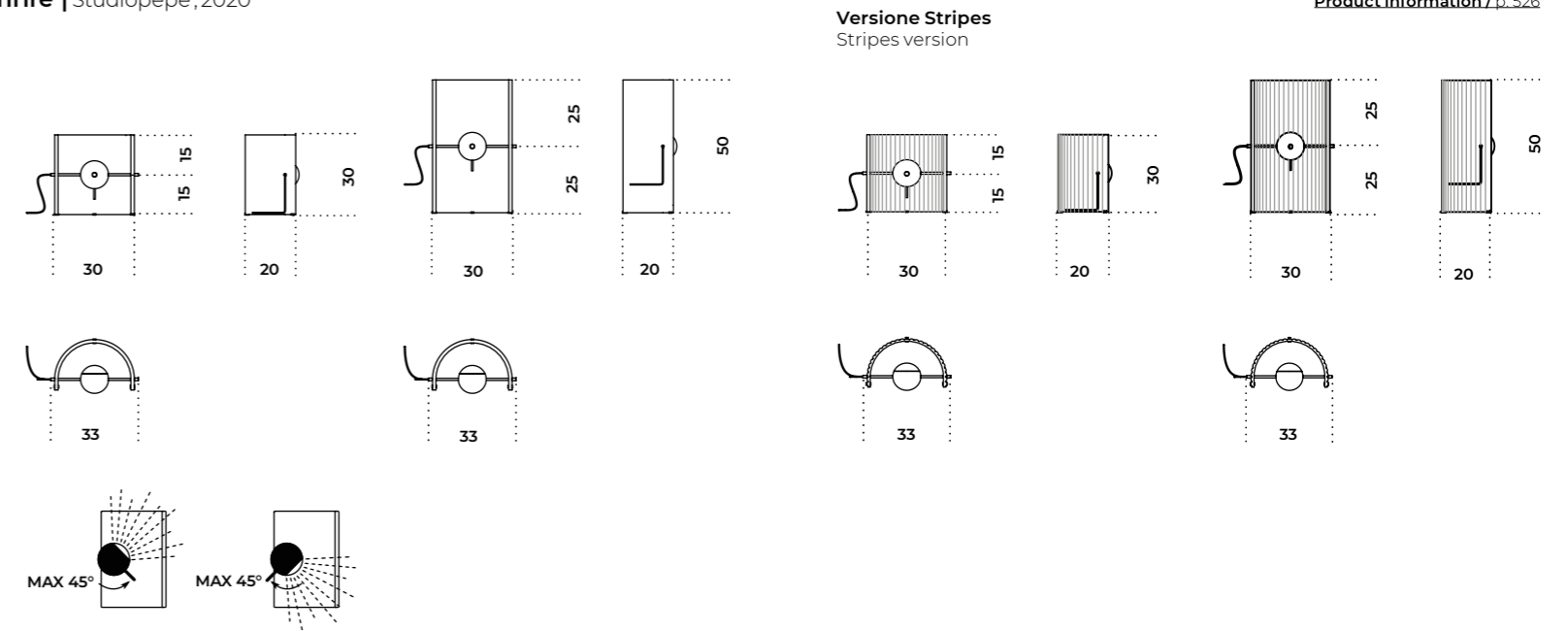

Bolle Terra | Massimo Castagna, 2015

Product information / p. 522

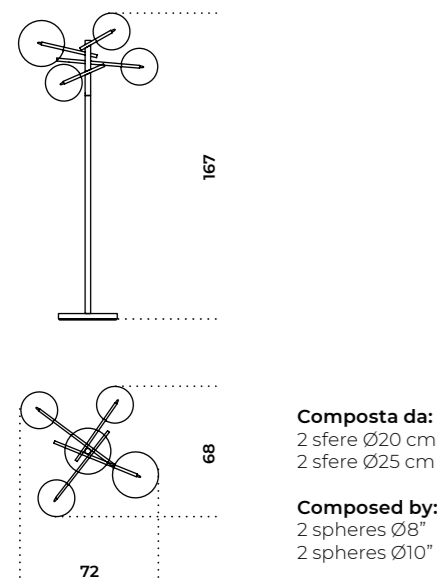

Composta da:
2 sfere Ø20 cm
2 sfere Ø25 cm

Composed by:
2 spheres Ø8"
2 spheres Ø10"

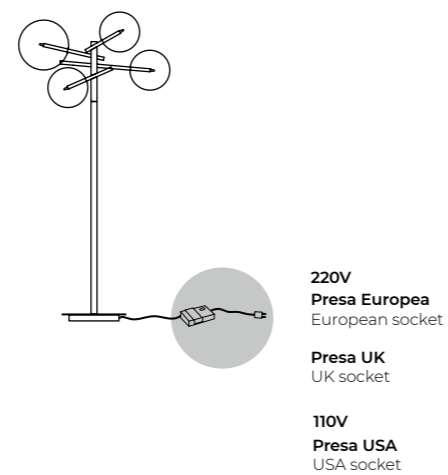

Diantha | Massimo Castagna, 2017

Product information / p. 528

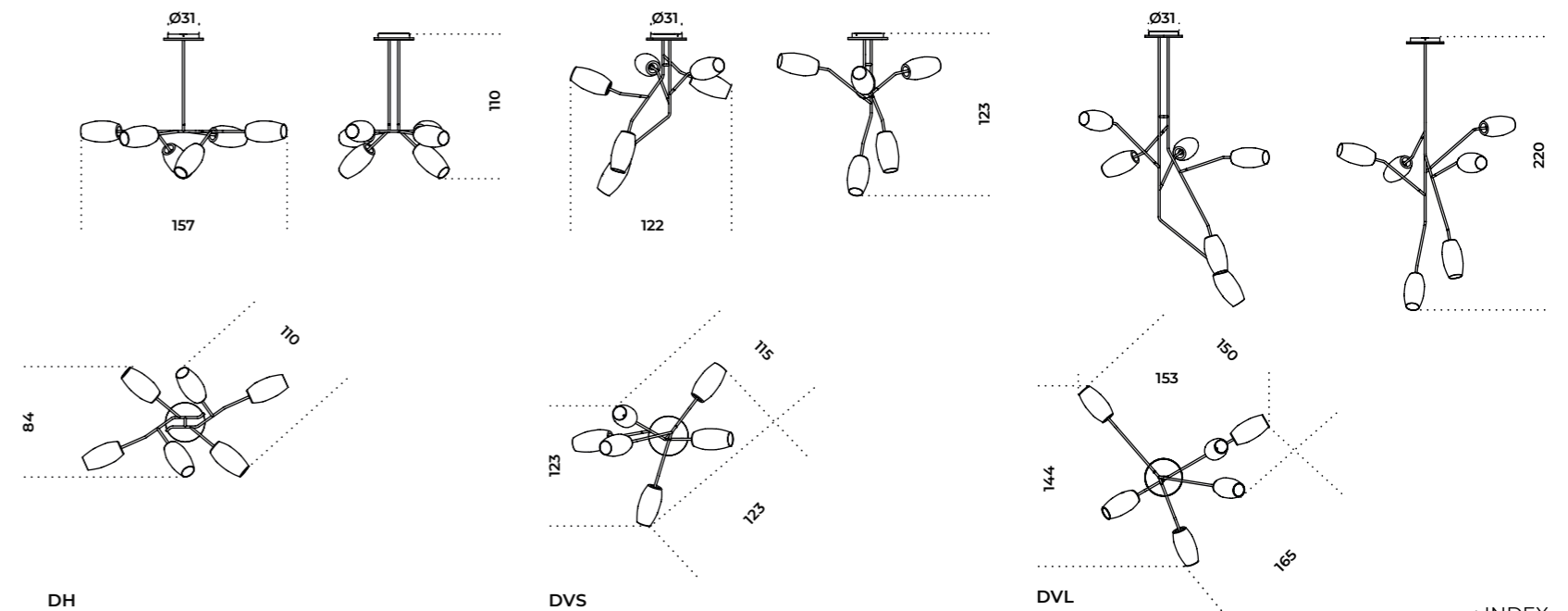

Diantha Terra | Massimo Castagna, 2018

Product information / p. 530

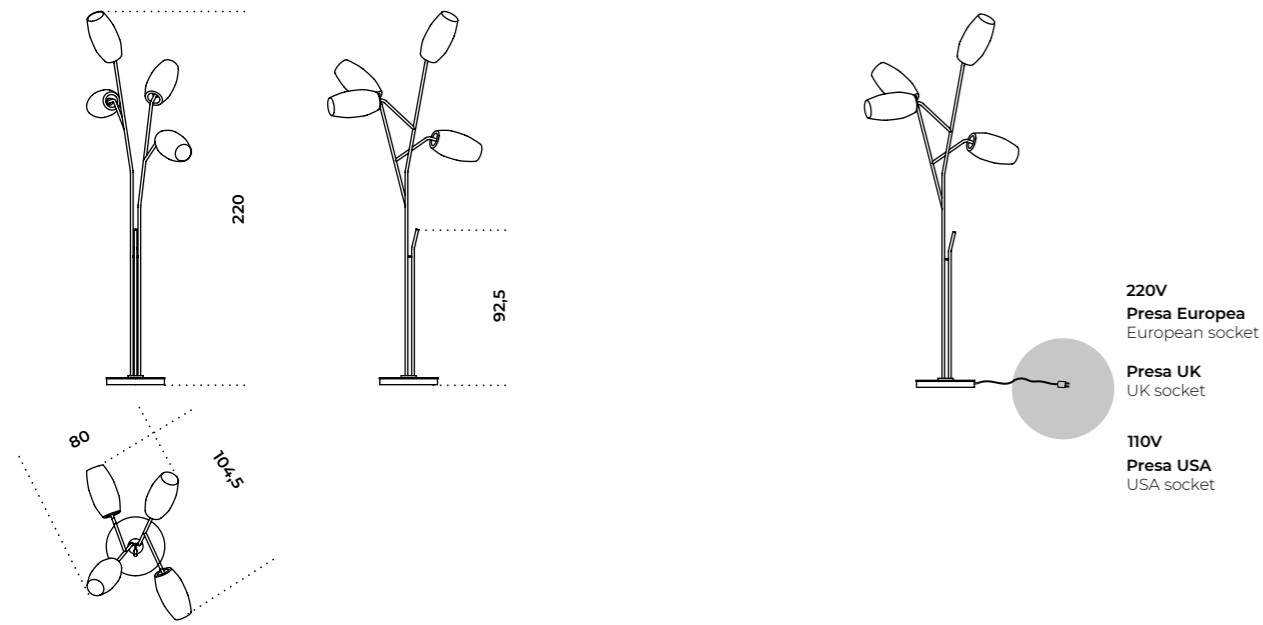

Eris | Massimo Castagna, 2017

Product information / p. 536

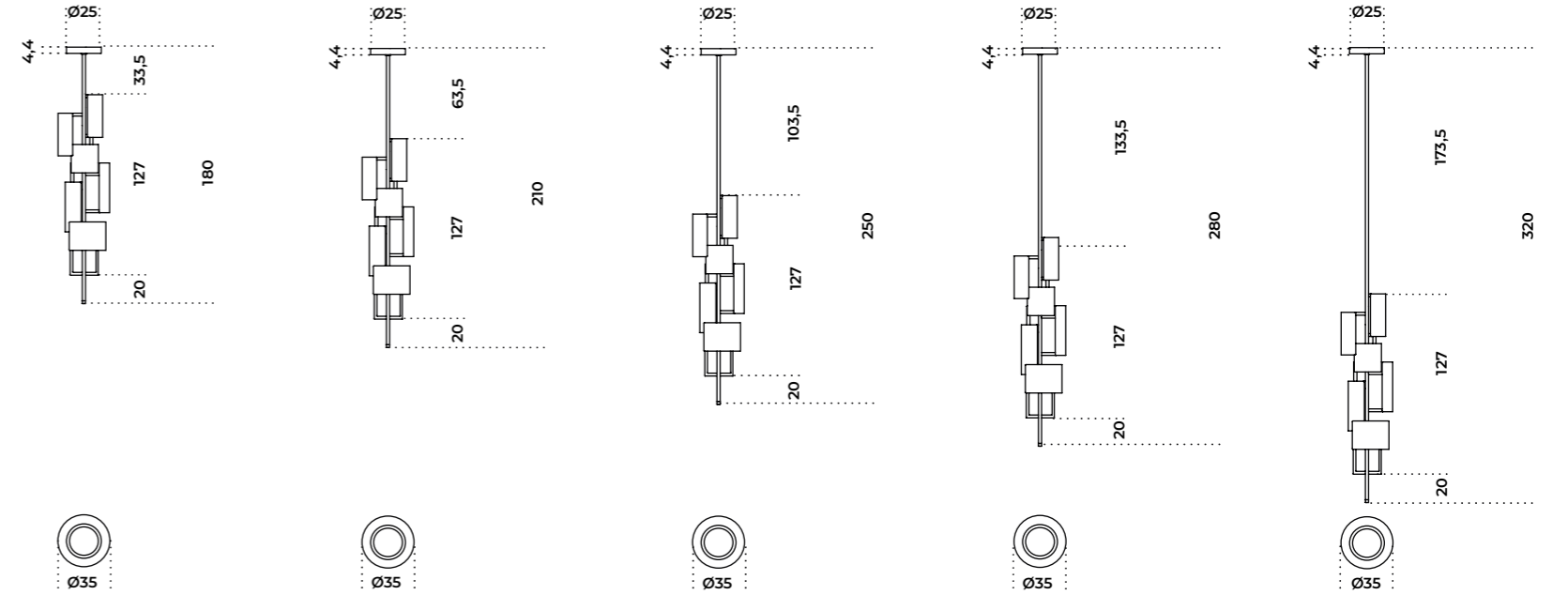

Epsilon | Massimo Castagna, 2016

Product information / p. 532

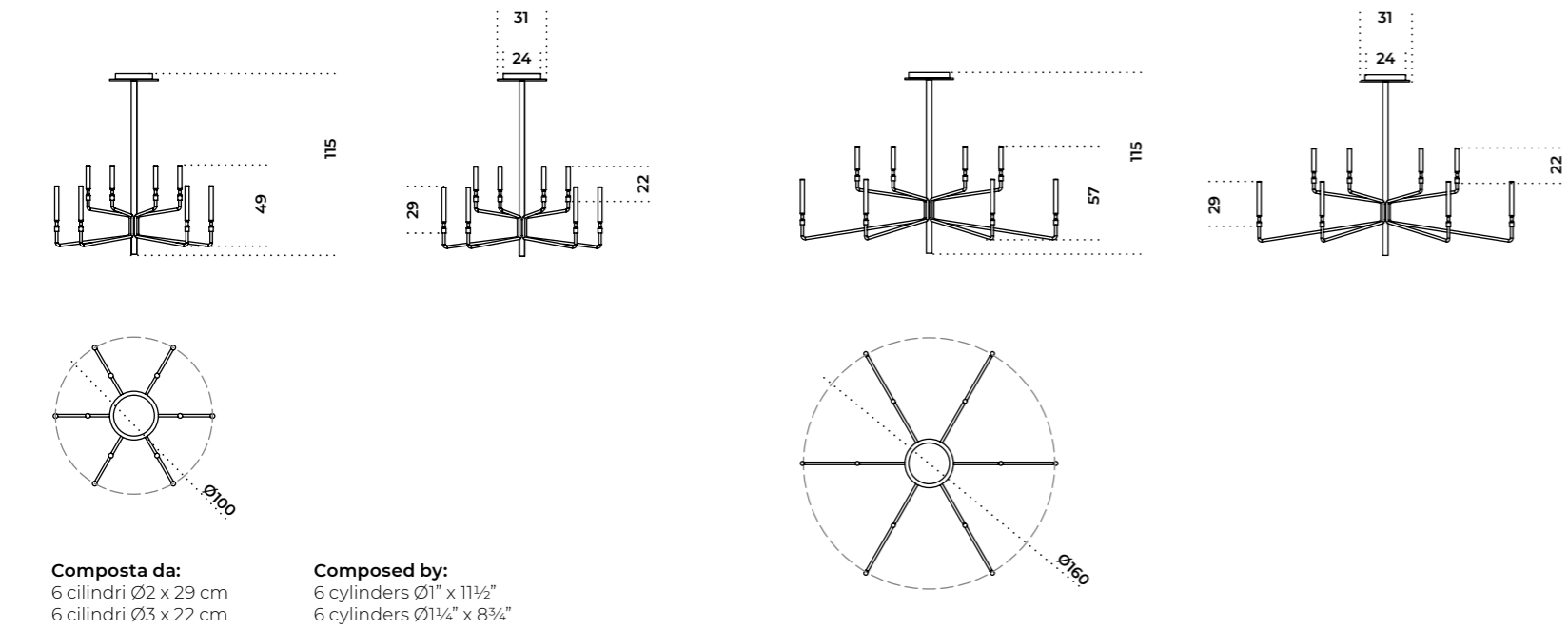

Jolie | Federica Biasi, 2019

Product information / p. 538

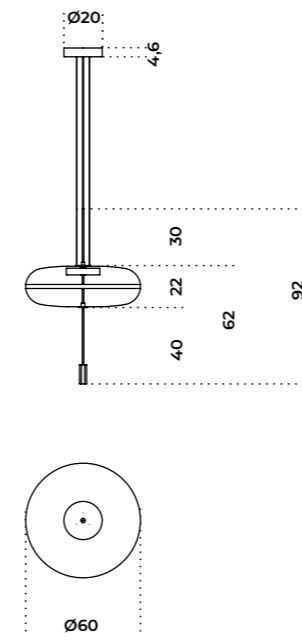

Epsilon Sola | Massimo Castagna, 2017

Product information / p. 534

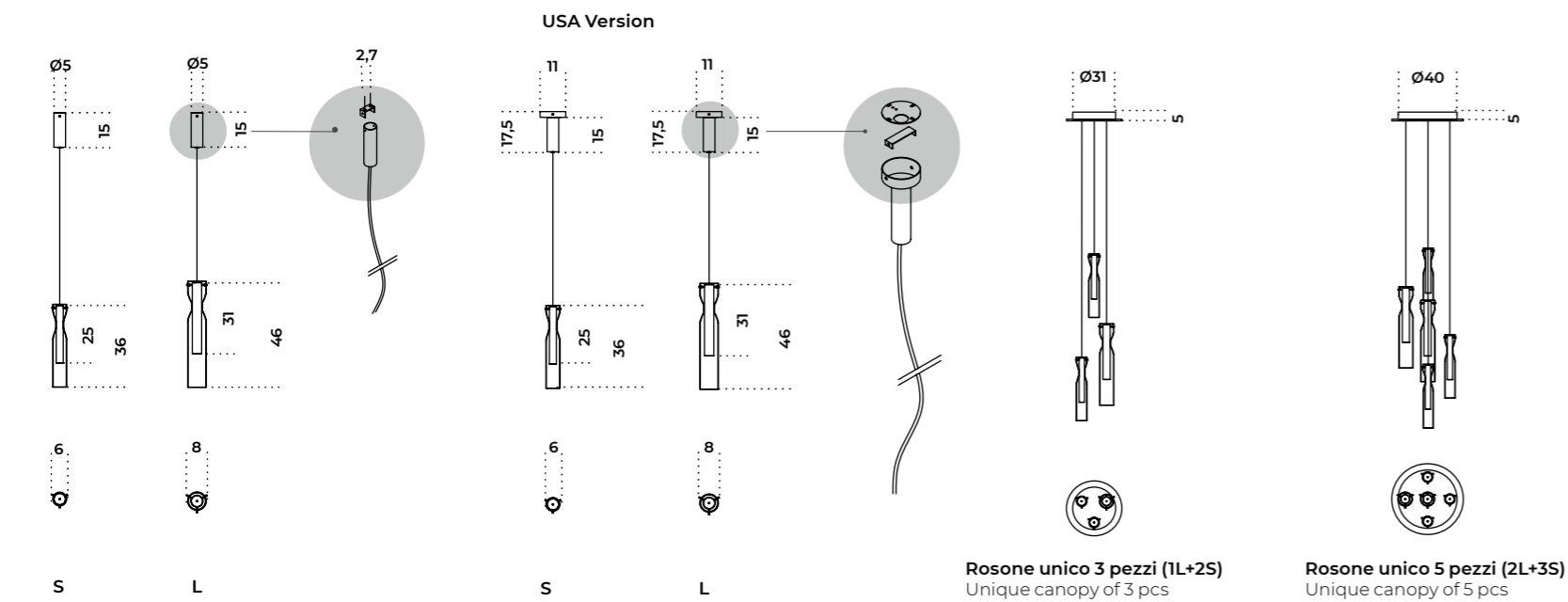

Jolie Applique | Federica Biasi, 2019

Product information / p. 540

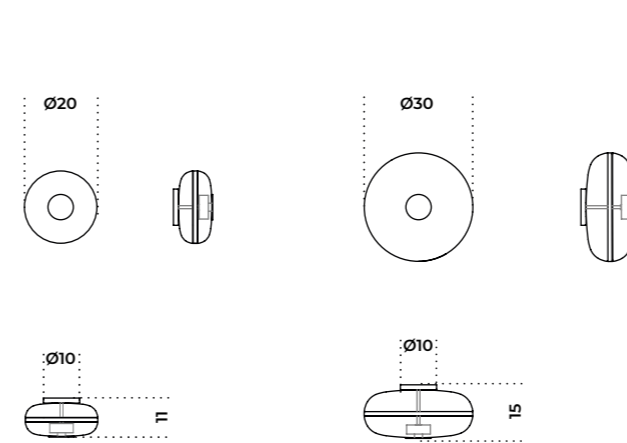

Key-to-Heaven | Massimo Castagna, 2022

[Product information / p. 542](#)

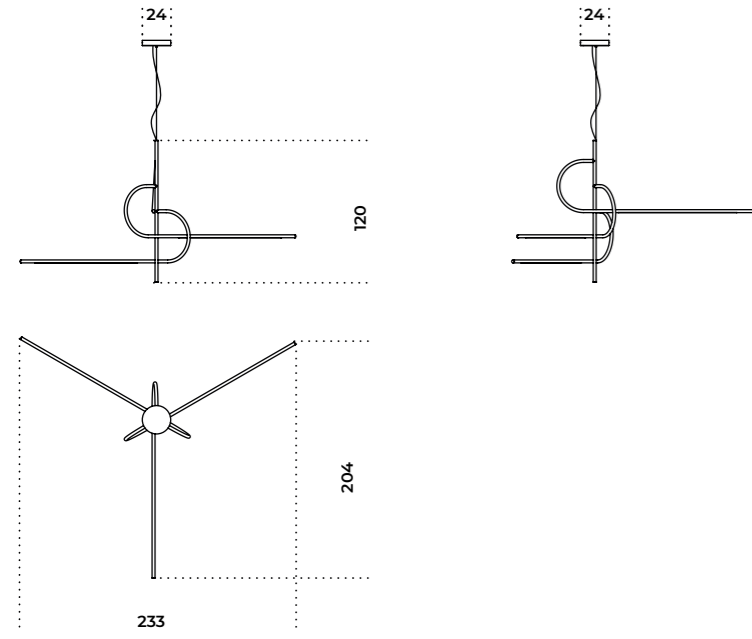

Narghilè | Massimo Castagna, 2018

[Product information / p. 546](#)

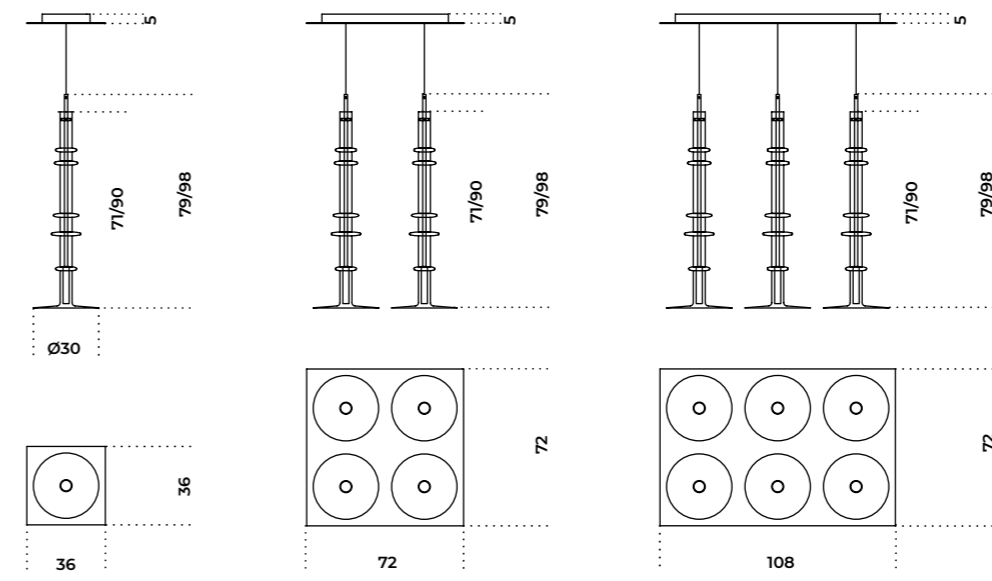

Key-to-Heaven Fix | Massimo Castagna, 2023

[Product information / p. 544](#)

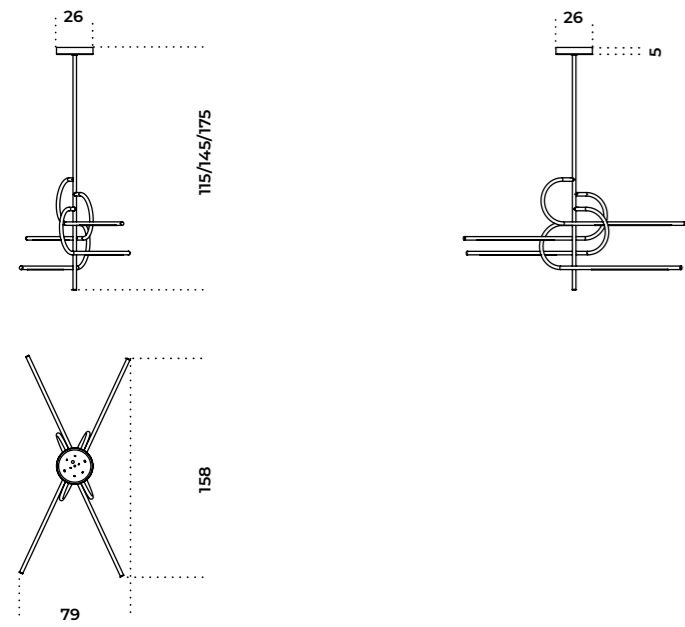

Ori | Massimo Castagna, 2017

[Product information / p. 548](#)

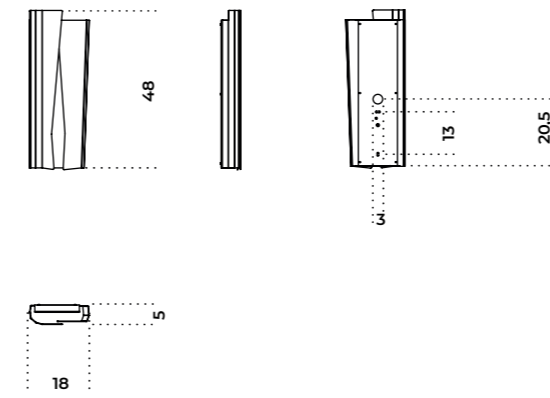

Versione A
A version

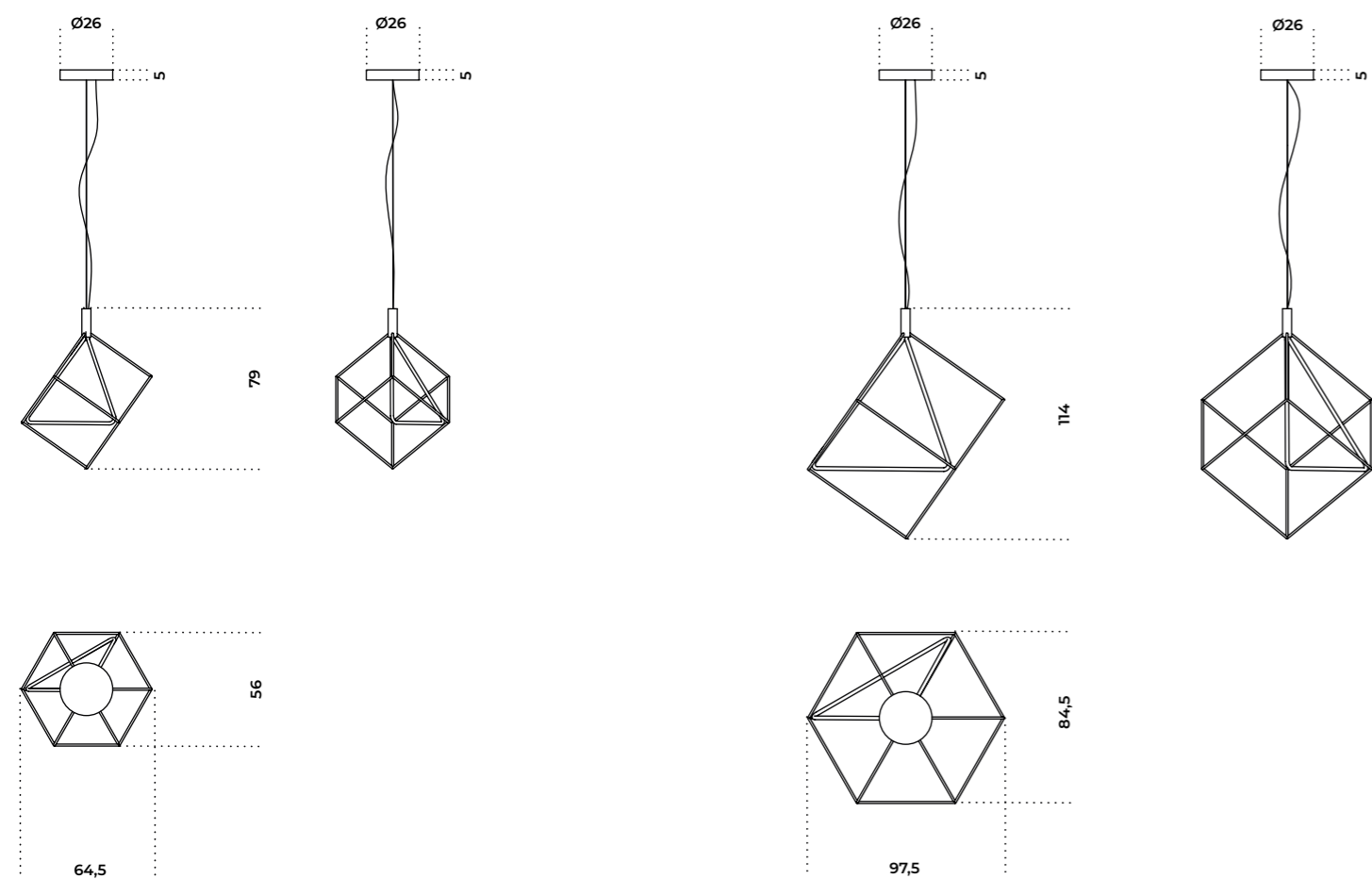

Versione B
B version

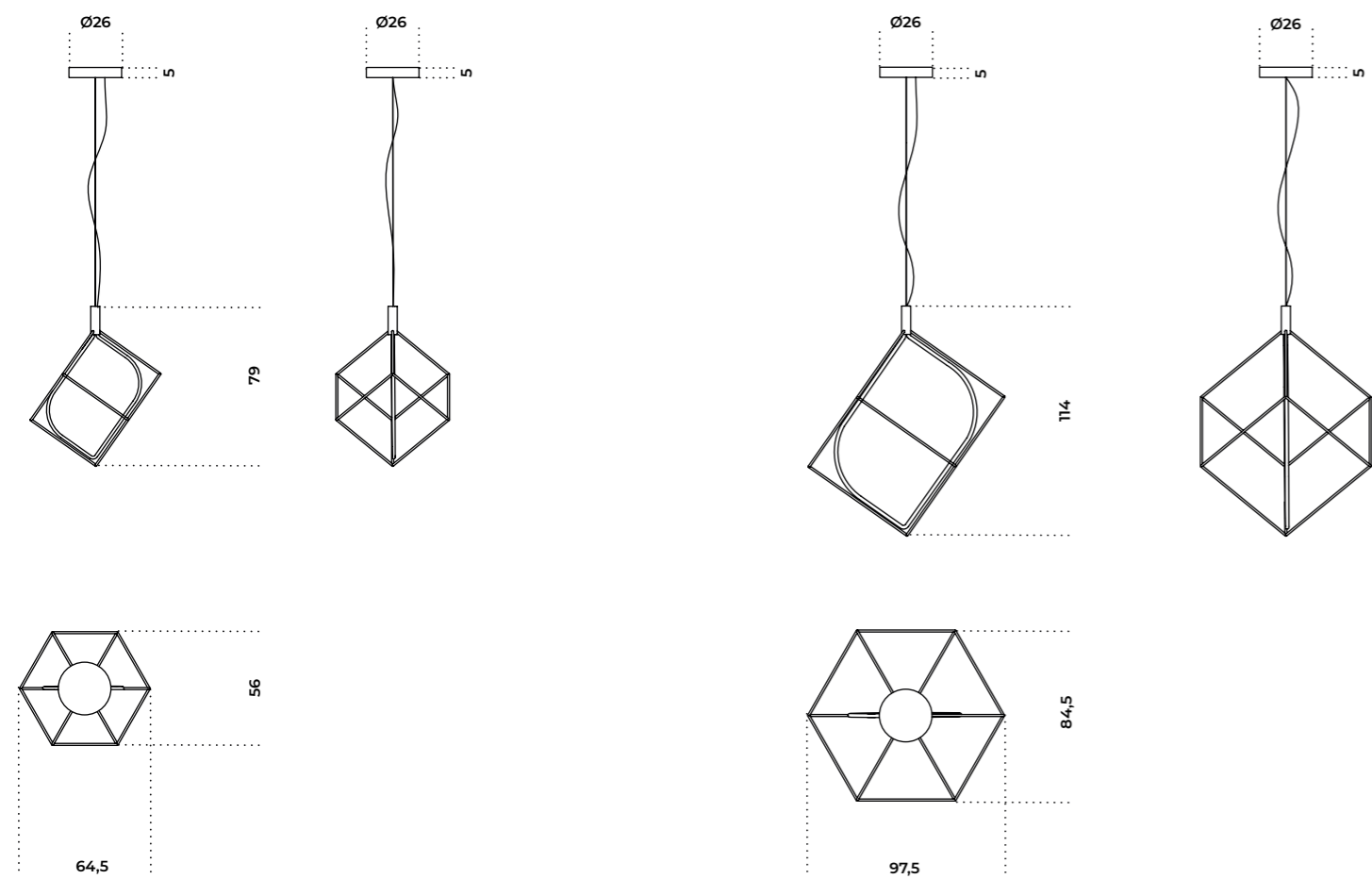

15 Specchi / Mirrors

- [568](#) **Black&White Beats**
- [570](#) **Cubista**
- [572](#) **Dream**
- [574](#) **Garda**
- [576](#) **Gemma**
- [578](#) **Keplero**
- [580](#) **Leaf**
- [582](#) **Lebel10**
- [584](#) **Niagara**
- [586](#) **Odette**
- [588](#) **Selene Mirror**
- [590](#) **Soft**
- [592](#) **Sole**
- [594](#) **Zed**
- [596](#) **Zeiss Mirror**

- [598](#) **Informazioni tecniche/
Technical informations**

Black&White Beat

Pietro Russo / 2016

Specchio 6mm bisellato e lucidato a mano con inserti in cristallo 6mm retroverniciato nero brillante. Composto da 42 cristalli specchiati e retroverniciati nero brillante.

6mm bevelled and polished by hand mirror with 6mm bright black painted glass inserts. Made of 42 mirrored and bright black painted glass.

! La creazione di questo prodotto è completamente artigianale. I 42 cristalli vengono molati e lucidati a mano, ogni elemento viene poi posizionato singolarmente per mantenere le distanze e ottenere il disegno geometrico che caratterizza questo modello. Ogni specchio è frutto di un lavoro meticoloso e di cura per il dettaglio. Tempo, precisione ed esperienza sono essenziali per la realizzazione di questo prodotto e confermano il suo valore.

! The creation of this product is completely handmade. The 42 glass pieces are ground and polished by hand, each element is then positioned individually to keep the distance and obtain the geometric design that characterizes this model. Each mirror is the result of meticulous work and attention to detail. Time, precision and experience are essential for the realization of this product and confirm its value.



Cm
142 x 142
182 x 182

Inches
56" x 56"
71¼" x 71¼"

For technical drawing / p. 600

Pricelist 2023 / p. 206

STRUTTURA/STRUCTURE



Specchio
Mirror

INSERTI/INSERTS

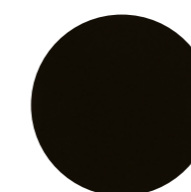

Cristallo retroverniciato
nero brillante
Bright black painted glass



Cubista

Pietro Russo / 2018

Specchio 6mm bisellato e lucidato a mano con inserti in cristallo 6mm retroverniciato nero brillante. Composto da 17 cristalli specchiati e retroverniciati nero brillante.

! La creazione di questo prodotto è completamente artigianale. I 17 cristalli vengono molati e lucidati a mano, ogni elemento viene poi posizionato singolarmente per mantenere le distanze e ottenere il disegno geometrico che caratterizza questo modello. Ogni specchio è frutto di un lavoro meticoloso e di cura per il dettaglio. Tempo, precisione ed esperienza sono essenziali per la realizzazione di questo prodotto e confermano il suo valore.

6mm bevelled and polished by hand mirror with 6mm bright black painted glass inserts. Made of 17 mirrored and bright black painted glass.

! The creation of this product is completely handmade. The 17 glass pieces are ground and polished by hand, each element is then positioned individually to keep the distance and obtain the geometric design that characterizes this model. Each mirror is the result of meticulous work and attention to detail. Time, precision and experience are essential for the realization of this product and confirm its value.



Cm
69,5 x 116

Inches
27½" x 45¾"

For technical drawing / p. 600

Pricelist 2023 / p. 207

STRUTTURA/STRUCTURE



Specchio
Mirror

INSERTI/INSERTS

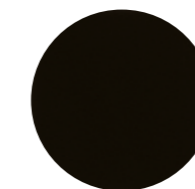

Cristallo retroverniciato
nero brillante
Bright black painted glass

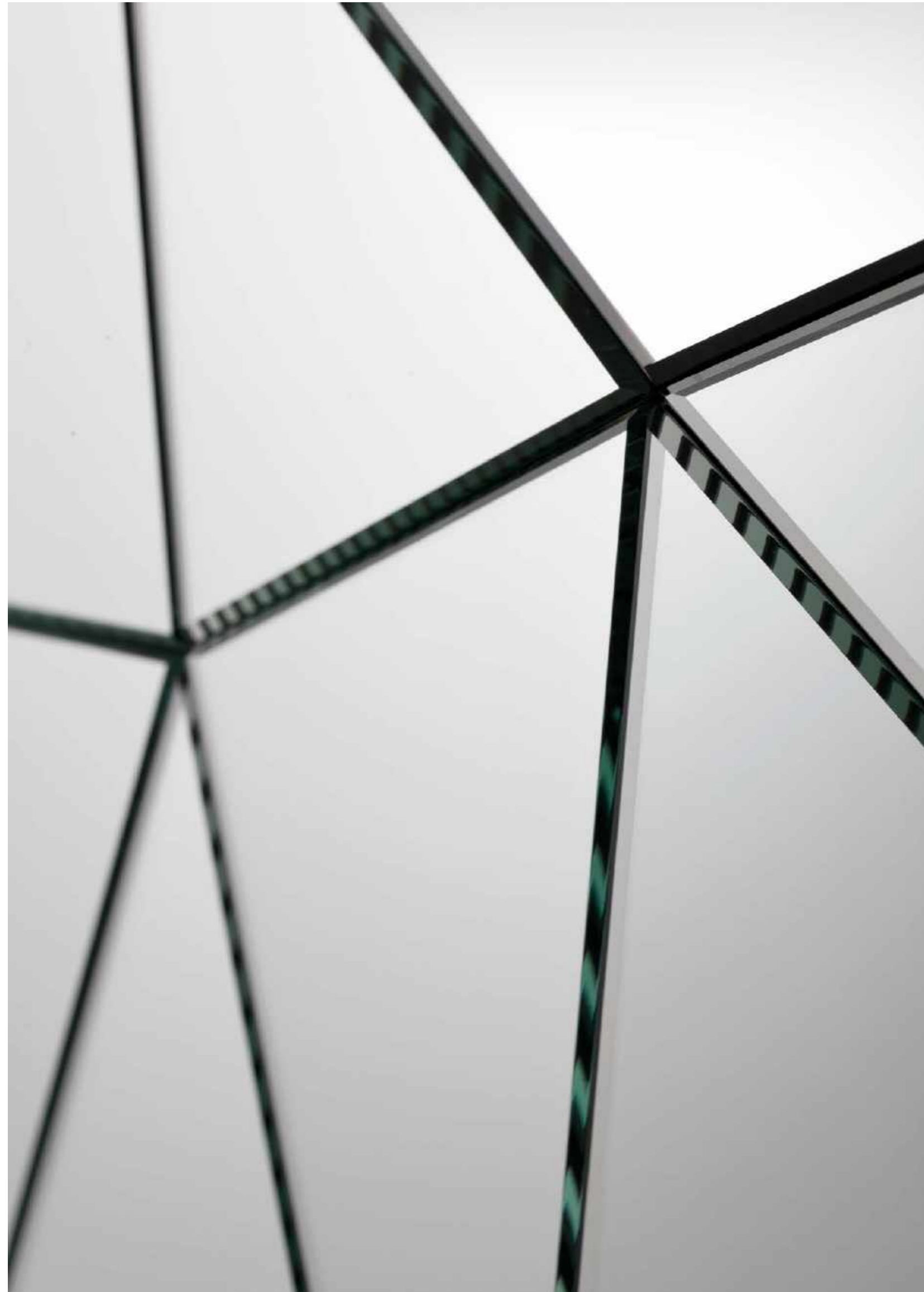

Dream

Ricardo Bello Dias / 2007

Specchio 5mm molato a mano con parte centrale ottagonale e cornice composta da 40 specchi inclinati su piani diversi.

! La creazione di questo prodotto è completamente artigianale. I 40 cristalli vengono molati e lucidati a mano, ogni elemento viene poi posizionato singolarmente per mantenere le distanze e ottenere il disegno geometrico che caratterizza questo modello. Ogni specchio è frutto di un lavoro meticoloso e di cura per il dettaglio. Tempo, precisione ed esperienza sono essenziali per la realizzazione di questo prodotto e confermano il suo valore.

5mm hand polished mirror with octagonal central part and frame composed of 40 mirrors inclined on different levels.

! The creation of this product is completely handmade. The 40 glass pieces are ground and polished by hand, each element is then positioned individually to keep the distance and obtain the geometric design that characterizes this model. Each mirror is the result of meticulous work and attention to detail. Time, precision and experience are essential for the realization of this product and confirm its value.



Cm
 Ø 120 x 6
 Ø 150 x 6

Inches
 47 1/4" x 2 1/2"
 59 1/4" x 2 1/2"

For technical drawing / p. 600

Pricelist 2023 / p. 208

STRUTTURA/STRUCTURE



Specchio
 Mirror

Garda

Federica Biasi / 2022

Specchio con parte in legno fresato laccato opaco nei colori "terracotta" (RAL 8002), "seta" (RAL 7044) o "caffè nero" (RAL 8022).
Su richiesta disponibile "Versione RAL" nel colore richiesto dal cliente.
È possibile creare composizioni accostando più specchi anche con diversi orientamenti.

Mirror with milled wooden part, available matt lacquered in the colour "terracotta" (RAL 8002), "seta" (RAL 7044) or "caffè nero" (RAL 8022).
"RAL Version" in the colour request by customer, on demand.
It is possible to create compositions by combining several mirrors even with different orientations.



Cm

A | 55 x 10 x 80
B | 55 x 10 x 80
C | 80 x 10 x 140
D | 80 x 10 x 140

Inches

21¾" x 4" x 31½"
21¾" x 4" x 31½"
31½" x 4" x 55¼"
31½" x 4" x 55¼"

[For technical drawing / p. 601](#)

[Pricelist 2023 / p. 209](#)
[Homescapes, gentle attitude / pp. 90, 92, 93, 104](#)

PARTE IN LEGNO/ WOODEN PART



Terracotta



Seta

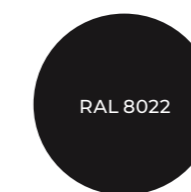

Caffè nero

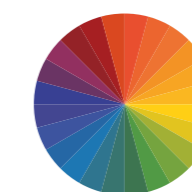

"Versione RAL"
"RAL Version"



Gemma

Studio G&R / 2013

Specchio extralight 6mm o "grigio Italia" 5mm con importante bisellatura da 25mm. 6mm extralight or 5mm smoked "grigio Italia" mirror with 25mm bevelled edge.



Cm
 60 x 8 x 60
 80 x 5 x 60
 120 x 2 x 35

Inches
 23¾" x 3¼" x 23¾"
 31½" x 2" x 23¾"
 47¼" x 1" x 14"

For technical drawing / p.601

Pricelist 2023 / p.210

STRUTTURA/STRUCTURE



Specchio extralight
Extralight mirror



Specchio "grigio Italia"
Smoked "grigio Italia" mirror



Keplero

Andrea Bassoli/2002

Specchio 6mm molato a mano.
Posizionabile sia in orizzontale che in verticale.

6mm hand polished mirror.
It can be placed both in a horizontal or vertical position.



Cm
26 x 200

Inches
10¼" x 78¾"

For technical drawing / p. 601

Pricelist 2023 / p. 211

STRUTTURA/STRUCTURE



Specchio
Mirror

Leaf

Ricardo Bello Dias / 2012

Sistema di specchi extralight 6mm o "grigio Italia" 5mm molati a bisello montati su pannelli a diverse inclinazioni. Disponibili in composizioni predefinite. Strutture di collegamento in metallo cromato o laccato color brunito.

System of 6mm extralight or 5mm smoked "grigio Italia" bevelled mirrors fixed on panels on different tilts. Available as per standard compositions. Chromed or burnished lacquered metal joint structure.

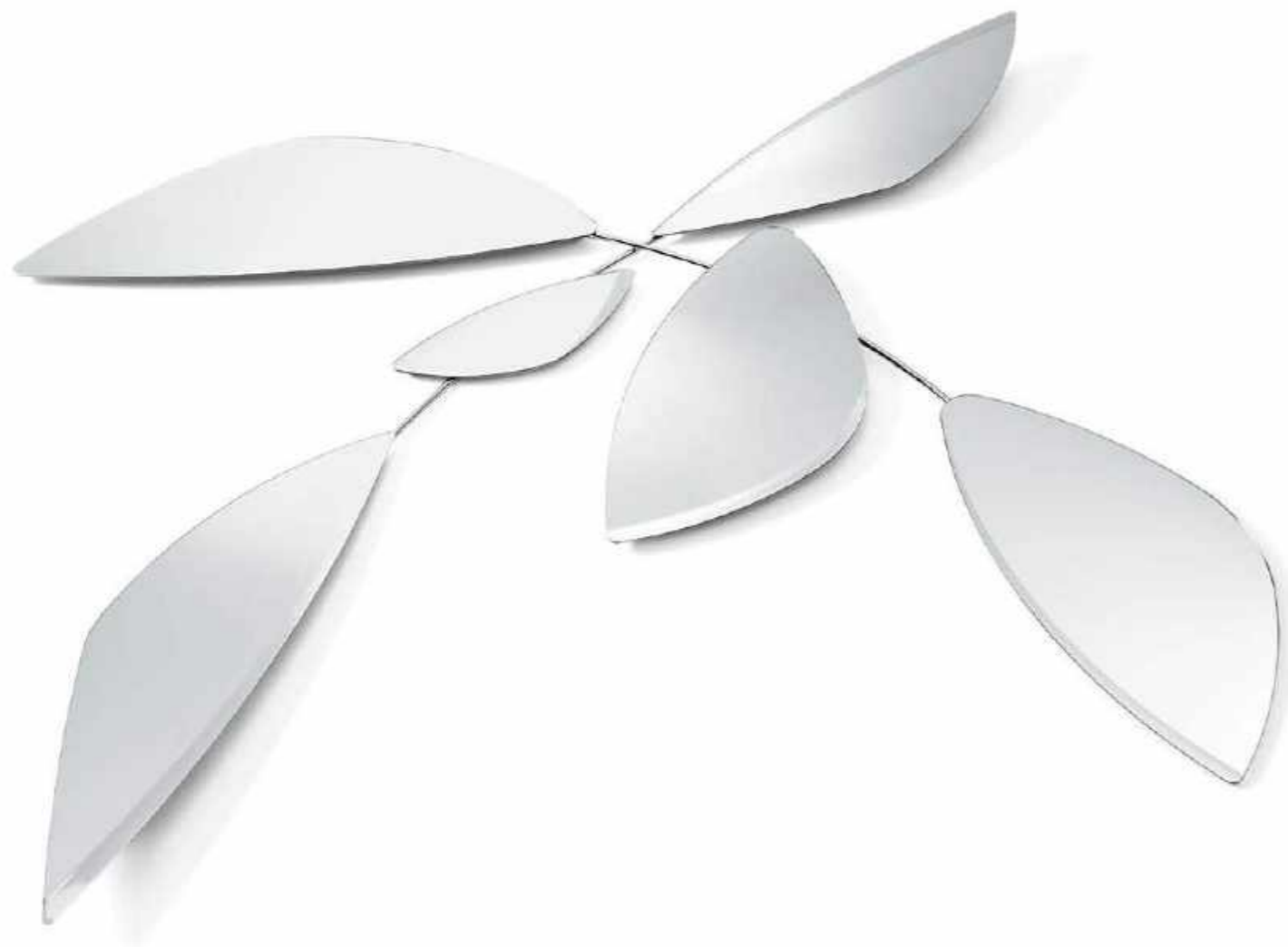

Cm
Composizione 1
215 x 200

Composizione 2
180 x 235

Inches
Composition 1
84³/₄" x 78³/₄"

Composition 2
71" x 92³/₄"

For technical drawing / p. 602

Pricelist 2023 / p. 212

SPECCHI/MIRRORS



Specchio extralight
Extralight mirror



Specchio "grigio Italia"
Smoked "grigio Italia" mirror

STRUTTURA/STRUCTURE



Metallo cromato
Chromed metal

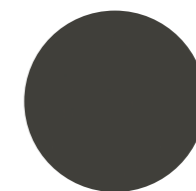

Metallo laccato color brunito
Burnished lacquered metal

▲ LEAF
Specchi extralight / Struttura in metallo cromato
Extralight mirror / Chromed metal structure



Level 10

Studio G&R / 2010

Specchio 6mm composto da due specchi sovrapposti molati.
Specchio superiore con importante bisellatura da 35mm.

6mm mirror made of two superimposed bevelled mirrors.
Upper mirror with bevelled edge 35mm.



Cm
Ø 100
Ø 120
Ø 140

100 x 100
120 x 120
140 x 140
50 x 200
80 x 200

Inches
Ø 39½"
Ø 47¼"
Ø 55¼"

39½" x 39½"
47¼" x 47¼"
55¼" x 55¼"
19¾" x 78¾"
31½" x 78¾"

For technical drawing / p.602

Pricelist 2023 / p.213

STRUTTURA/STRUCTURE



Specchio
Mirror



Niagara

Pierangelo Gallotti / 1987

Specchio 6mm composto da due specchi molati, accostati e sovrapposti ad una parte in cristallo specchiato "grigio Italia". Specchi superiori con importante bisellatura centrale irregolare eseguita a mano.

! La creazione di questo prodotto è completamente artigianale. I due semicerchi vengono pinzati a mano per conferire l'irregolarità della spaccatura centrale, successivamente molati e lucidati a mano. La particolarità di questa lavorazione rende ogni prodotto unico e non replicabile. Ogni specchio è frutto di un lavoro meticoloso e di cura per il dettaglio. Tempo, precisione ed esperienza sono essenziali per la realizzazione di questo prodotto e confermano il suo valore.

6mm mirror composed of two bevelled mirrors placed side by side and superimposed on a smoked "grigio Italia" mirrored part. Upper mirrors with important irregular central bevel done by hand.

! The creation of this product is completely handmade. The two semicircles are clamped by hand to give the irregularity of the central part, then ground and polished by hand. The particularity of this workmanship makes each product unique and non-replicable. Each mirror is the result of meticulous work and attention to detail. Time, precision and experience are essential for the realization of this product and confirm its value.



Cm	Inches
Ø 80	Ø 31½"
Ø 100	Ø 39½"
Ø 120	Ø 47¼"
80 x 80	31½" x 31½"
100 x 100	39½" x 39½"

For technical drawing / p. 603

Pricelist 2023 / p. 214

STRUTTURA/STRUCTURE



Specchio
Mirror



▲ ODETTE
Specchio "Antique 2" / Dettaglio in ottone lucido
"Antique 2" mirror / bright brass detail

Odette

Studio G&R / 2015

Specchio extralight 6mm con particolare decorativo in ottone lucido posizionabile a discrezione lungo il perimetro.
Disponibile anche in specchio 5mm "Antique 1" o "Antique 2".

6mm extralight mirror with bright brass decorative detail, which can be placed around the perimeter, according to the customer choice.
Also available in 5mm "Antique 1" or "Antique 2" mirror.



Cm

Ø 50
Ø 80

58 x 36
76 x 47
60 x 60
80 x 80
30 x 140

Inches

Ø 19¾"
Ø 31½"

23" x 14¼"
30" x 18¾"
23¾" x 23¾"
31½" x 31½"
12" x 55¼"

For technical drawing / p. 603

Pricelist 2023 / p. 215

SPECCHIO/MIRROR



Specchio extralight
Extralight mirror

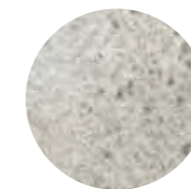

Specchio "Antique 1"
"Antique 1" mirror



Specchio "Antique 2"
"Antique 2" mirror

DETTAGLIO/DETAILS

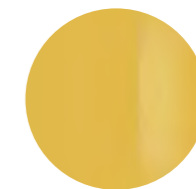

Ottone lucido
Bright brass

Selene Mirror

Pietro Russo / 2016

Specchio vanity da tavolo dotato di luce LED. Specchio extralight 6mm con bisello 20mm. Parti metalliche laccate ottone satinato e base in marmo levigato opaco Nero Marquinia.

Vanity mirror with LED light. 6mm extralight mirror with bevel 20mm. Satin brass lacquered metal parts and honed mat Nero Marquinia marble base.



Cm
Ø40 x 12 x 65

Inches
Ø15¾" x 4¾" x 25¾"

For technical drawing / p. 603

Pricelist 2023 / p. 216

SPECCHIO/MIRROR



Specchio extraligh
Extralight mirror

PARTI METALLICHE/ METAL PARTS



Laccato ottone satinato
Satin brass lacquered

BASE/BASE



Marmo levigato opaco
Nero Marquinia
Honed mat Nero Marquinia
marble

LUCE/LIGHT

LED
15 Watt
108 lm
3000°K

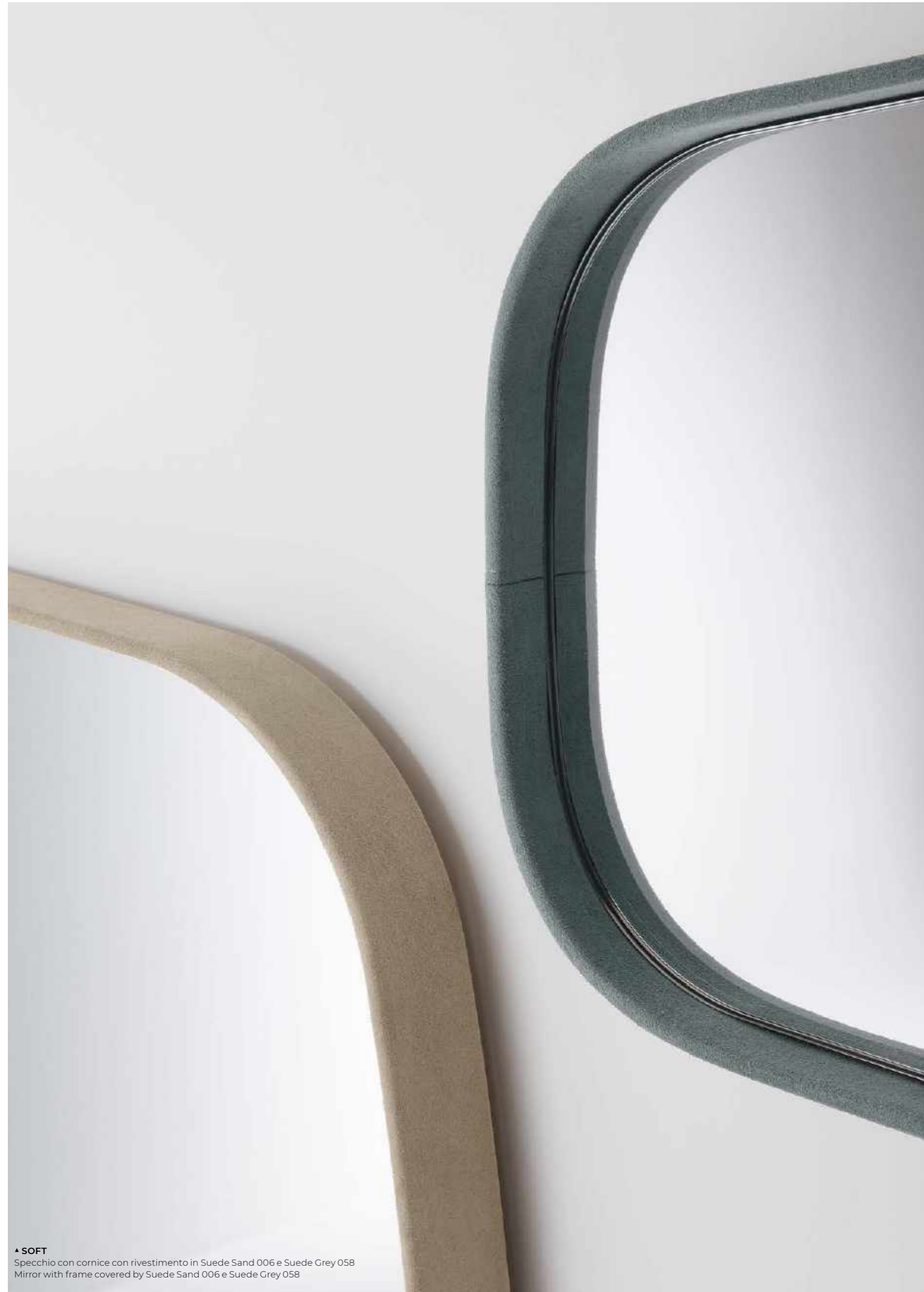

▲ **SOFT**
Specchio con cornice con rivestimento in Suede Sand 006 e Suede Grey 058
Mirror with frame covered by Suede Sand 006 e Suede Grey 058

Soft

Studio G&R / 2014

Specchio 6mm con cornice (profondità 5cm) rivestita in pelle scamosciata nei colori del campionario.

6mm mirror with frame (thickness 5cm) covered by suede as per samples.

! Non realizzabile su misura.

! Not available in custom size.



Cm
80 x 80
115 x 150
40 x 180

Inches
31½" x 31½"
45½" x 59¼"
15¾" x 71"

[For technical drawing / p. 604](#)

[Pricelist 2023 / p. 217](#)

STRUTTURA/STRUCTURE



Specchio
Mirror

CORNICE/FRAME

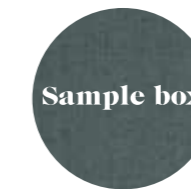

Pelle scamosciata nei colori del campionario
Suede as per samples

Sole

Studio G&R/1975

Specchio 6mm composto da due specchi sovrapposti.
Specchio centrale con bisellatura da 30mm.

6mm mirror made of two superimposed mirrors.
Central mirror with 30mm bevelled edge.



Cm
Ø 150
Ø 165

Inches
Ø 59¼"
Ø 65"

[For technical drawing / p. 604](#)

[Pricelist 2023 / p. 218](#)
[Homescapes, gentle attitude / p. 84](#)

STRUTTURA/STRUCTURE



Specchio
Mirror



Zed

Ricardo Bello Dias / 2006

Specchio 6mm con struttura autoportante in metallo piegato e verniciato color grigio umbro.

6mm mirror with freestanding dark grey lacquered bent metal structure.

Cm
30 x 39 x 175

Inches
12" x 15½" x 69"

[For technical drawing / p. 604](#)

[Pricelist 2023 / p. 219](#)

SPECCHIO/MIRROR



Specchio
Mirror

STRUTTURA/STRUCTURE

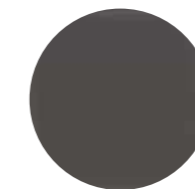

**Metallo verniciato
grigio umbro**
Dark grey lacquered metal



Zeiss Mirror

Luca Nichetto/2009

Specchio extralight 6mm molato e bisellato a mano, in tre diverse forme e dimensioni. Cornice in legno (spessore 5cm) laccato bianco oppure effetto "tessuto" nei colori castagna, sabbia e canapa.

6mm hand polished and bevelled extralight mirror in three different shapes and sizes. White lacquered wooden frame (thickness 5cm) or lacquered with "fabric" touch effect in the colours chestnut, sand and canapa.



	Cm	Inches
S	80 x 6 x 78	31½" x 2½" x 30¾"
M	104 x 6 x 92	41" x 2½" x 36¼"
L	156 x 6 x 151	61½" x 2½" x 59½"

[For technical drawing / p. 605](#)

[Pricelist 2023 / p. 220](#)
[Homescapes, sense of materials / p. 108](#)
[Homescapes, gentle attitude / pp. 54, 55](#)

SPECCHIO/MIRROR



Specchio extralight
Extralight mirror

CORNICE/FRAME



Legno laccato bianco
White lacquered wood

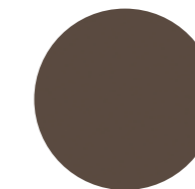

Legno laccato effetto
"tessuto" color castagna
Chestnut with "fabric"
touch effect lacquered



Legno laccato effetto
"tessuto" color sabbia
Sand with "fabric"
touch effect lacquered



Legno laccato effetto
"tessuto" color canapa
Canapa with "fabric"
touch effect wood

15

Specchi / Mirrors
TECHNICAL MODULE

Black&White Beat | Pietro Russo, 2016

Product information / p. 568

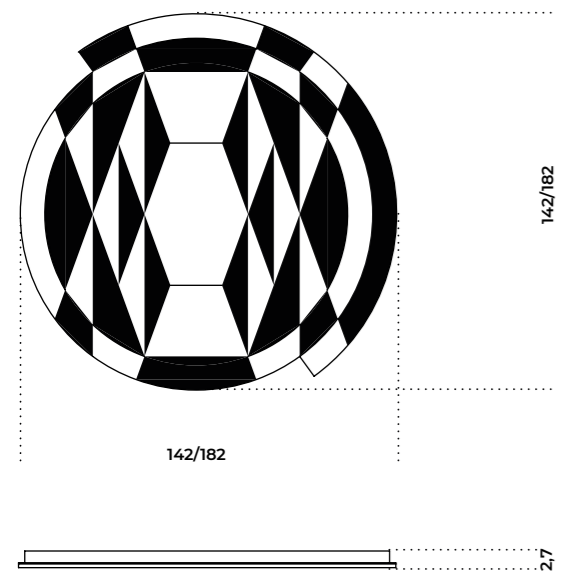

Cubista | Pietro Russo, 2018

Product information / p. 570

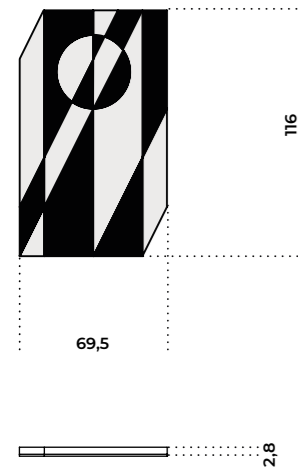

Dream | Ricardo Bello Dias, 2007

Product information / p. 572

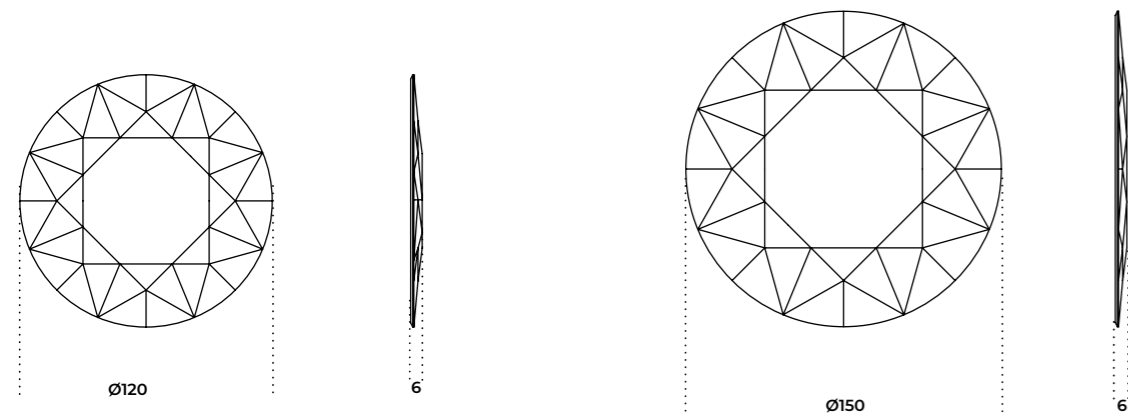

Garda | Federica Biasi, 2022

Product information / p. 574

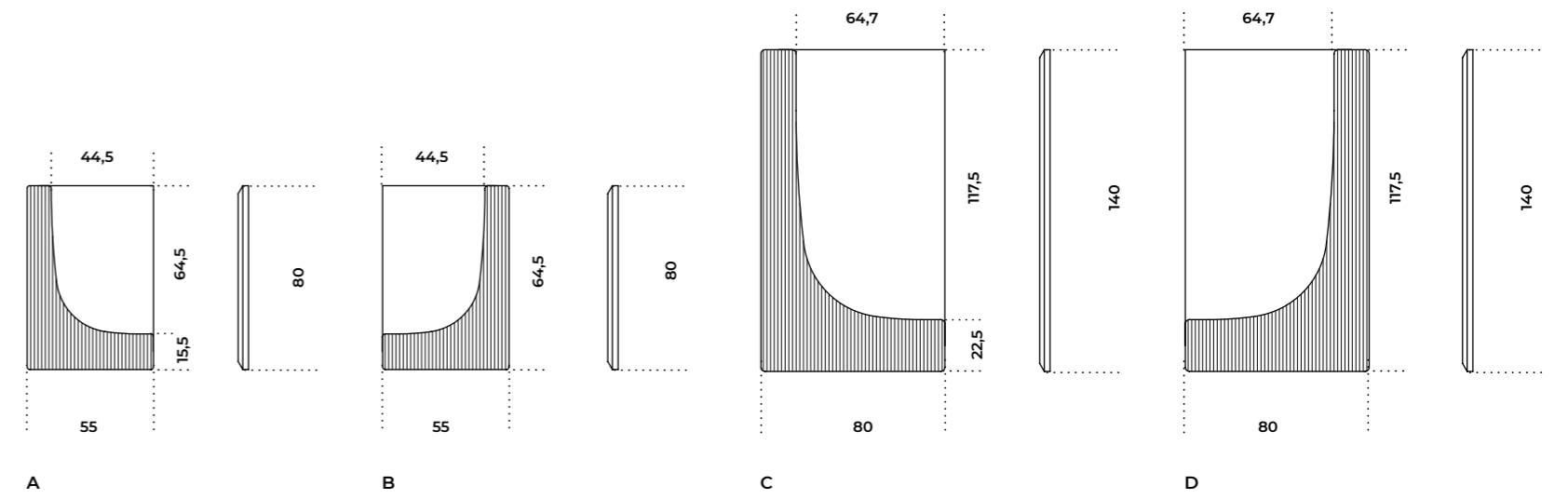

Gemma | Studio G&R, 2013

Product information / p. 576

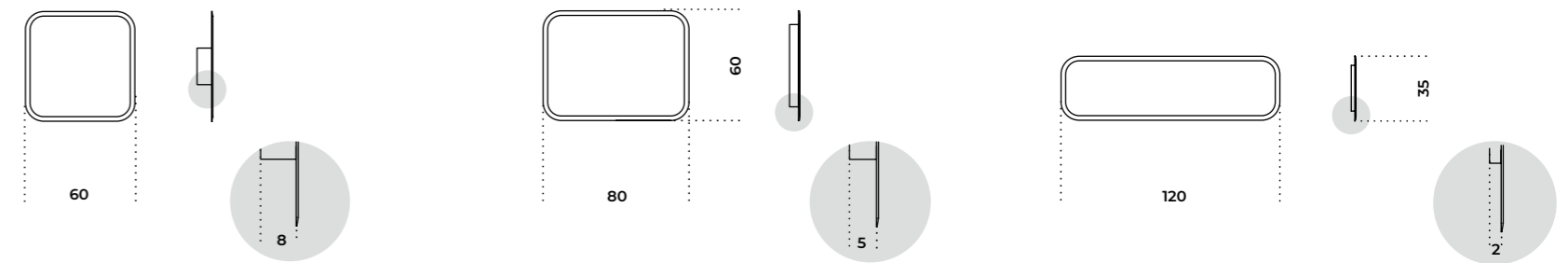

Keplero | Andrea Bassoli, 2002

Product information / p. 578

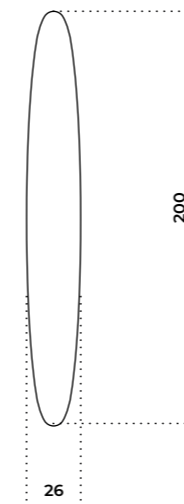

Leaf | Ricardo Bello Dias, 2012

Product information / p. 580

Composizione 1
Composition 1

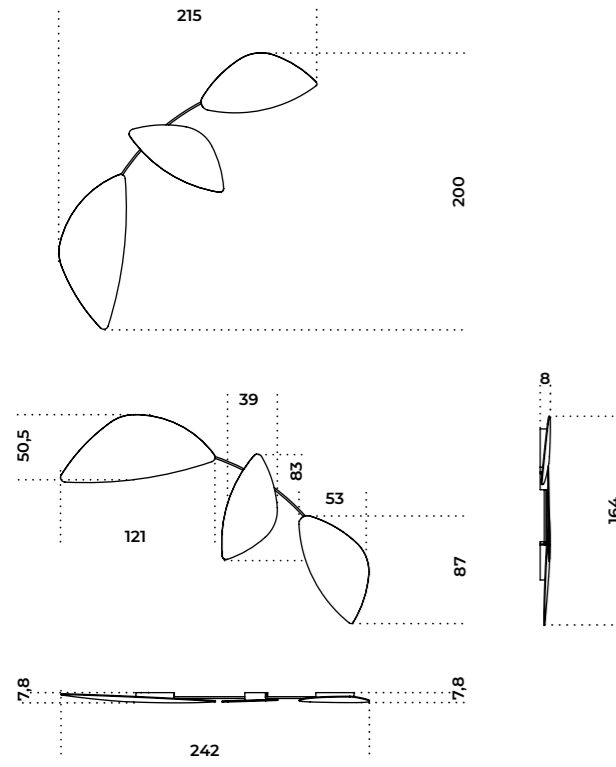

Composizione 2
Composition 2

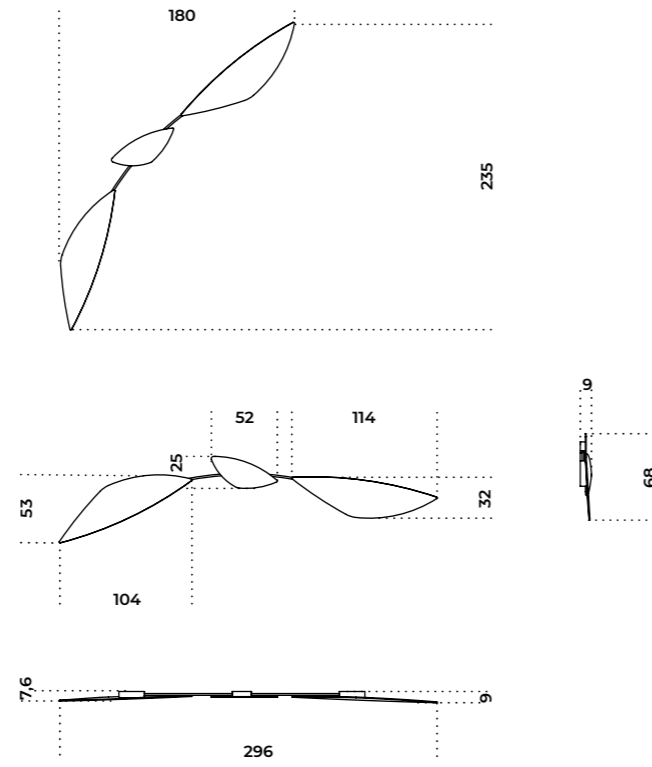

Combinazione 1 / Combination 1

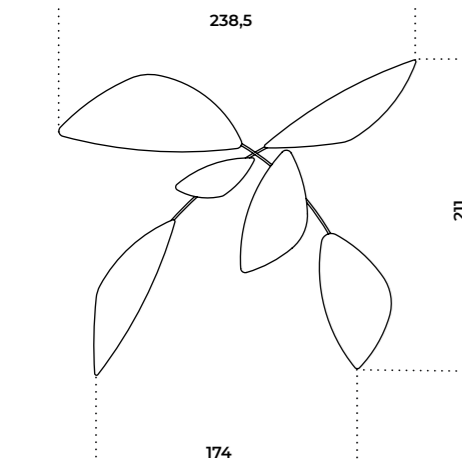

Combinazione 2 / Combination 2

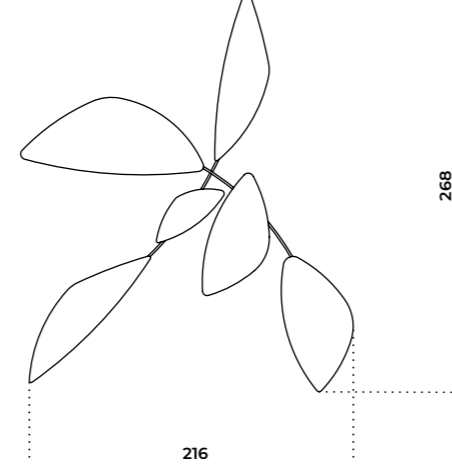

Lebel 10 | Studio G&R, 2010

Product information / p. 582

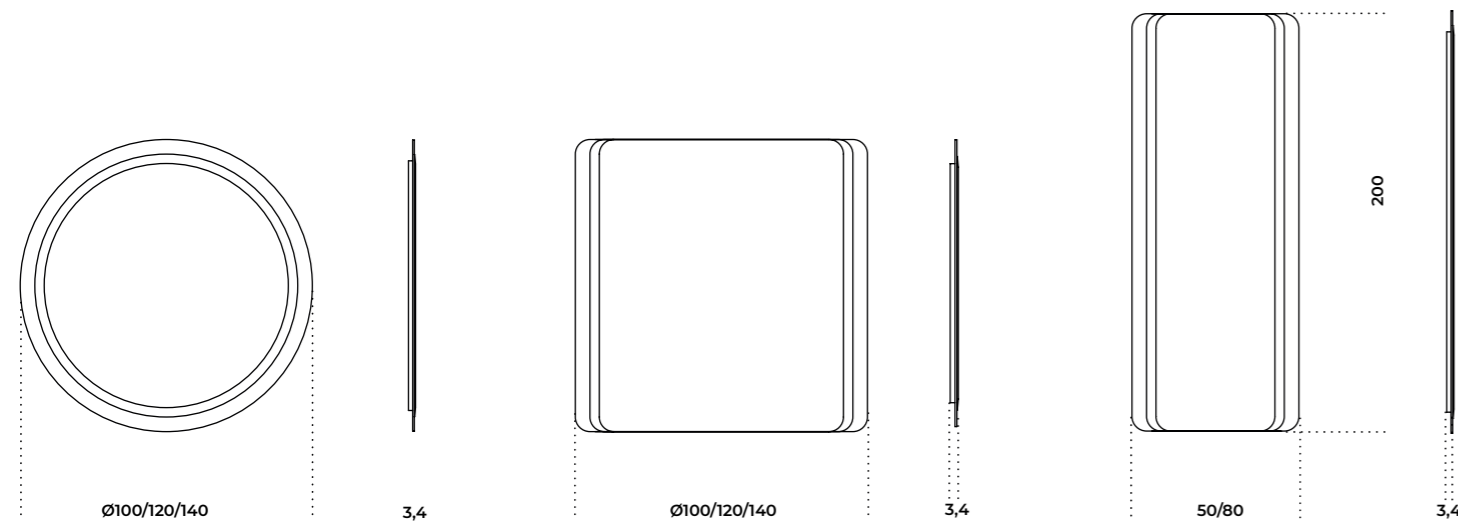

Niagara | Pierangelo Gallotti, 1987

Product information / p. 584

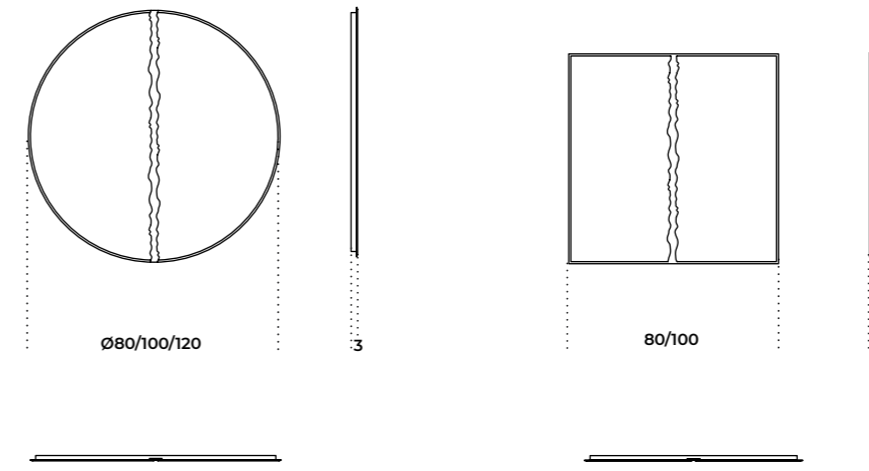

Odette | Studio G&R, 2015

Product information / p. 586

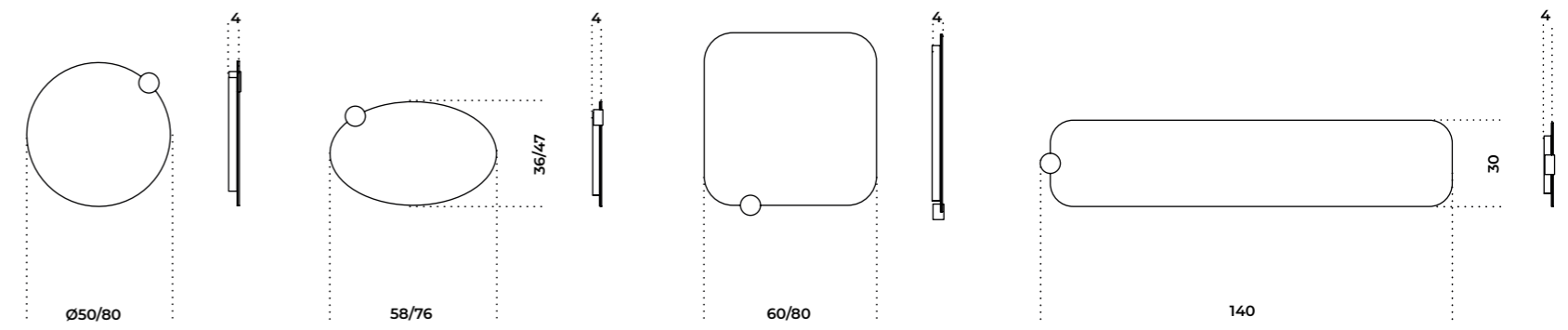

Selene Mirror | Pietro Russo, 2016

Product information / p. 588

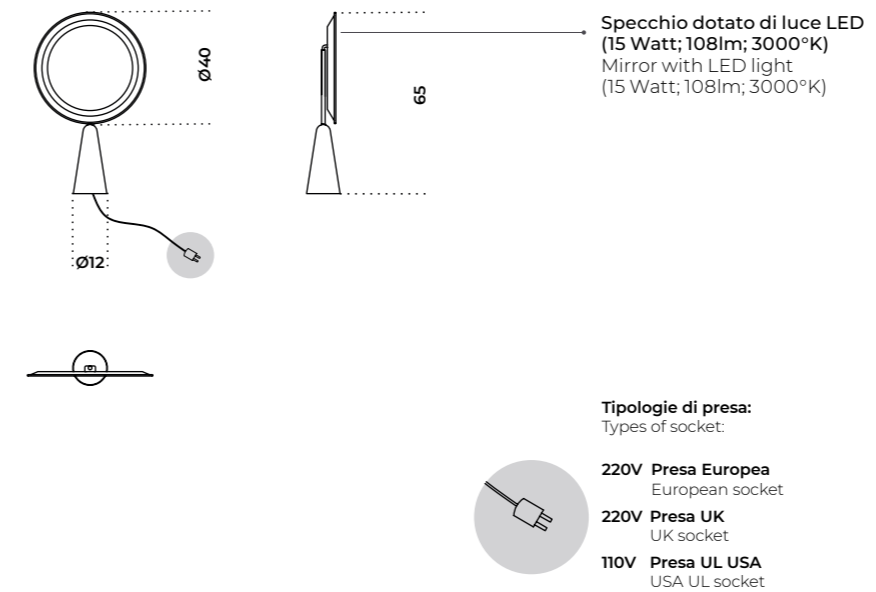

Soft | Studio G&R, 2014

Product information / p. 590

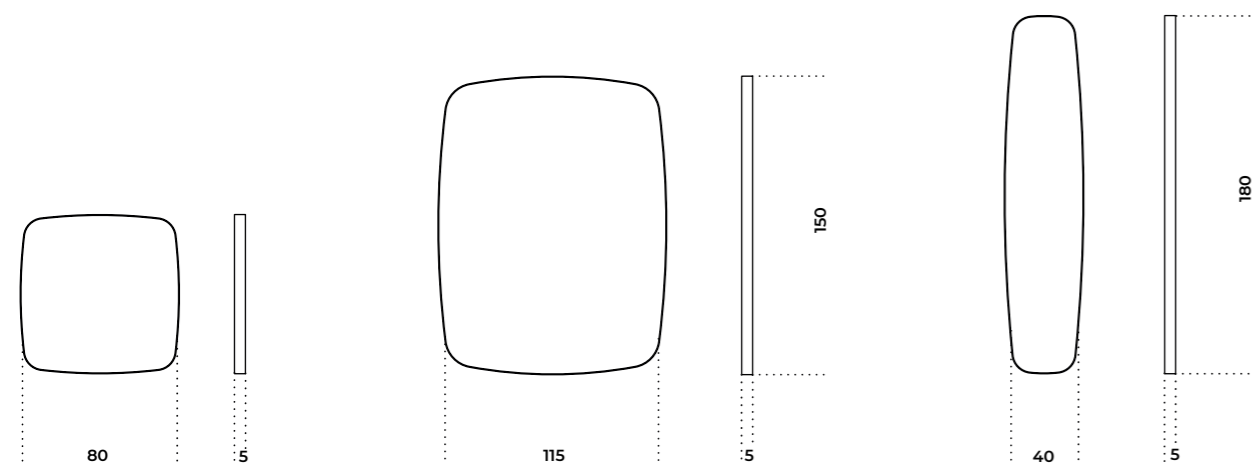

Zeiss Mirror | Luca Nichetto, 2009

Product information / p. 596

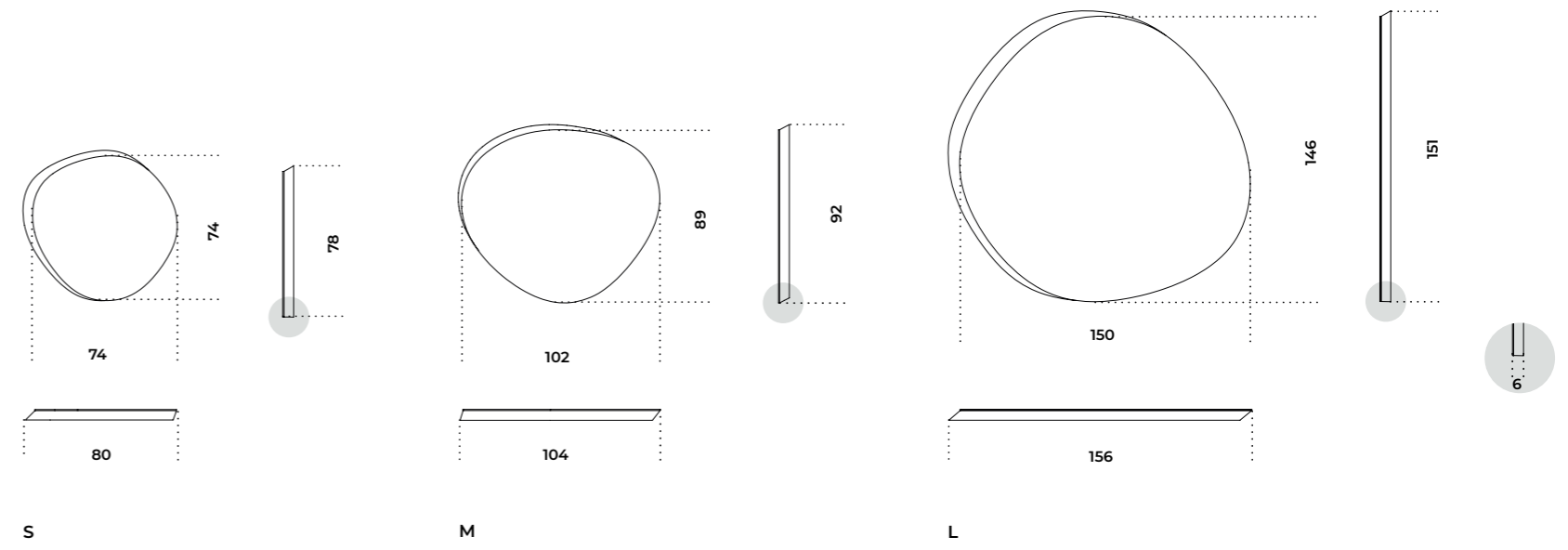

Sole | Studio G&R, 1975

Product information / p. 592

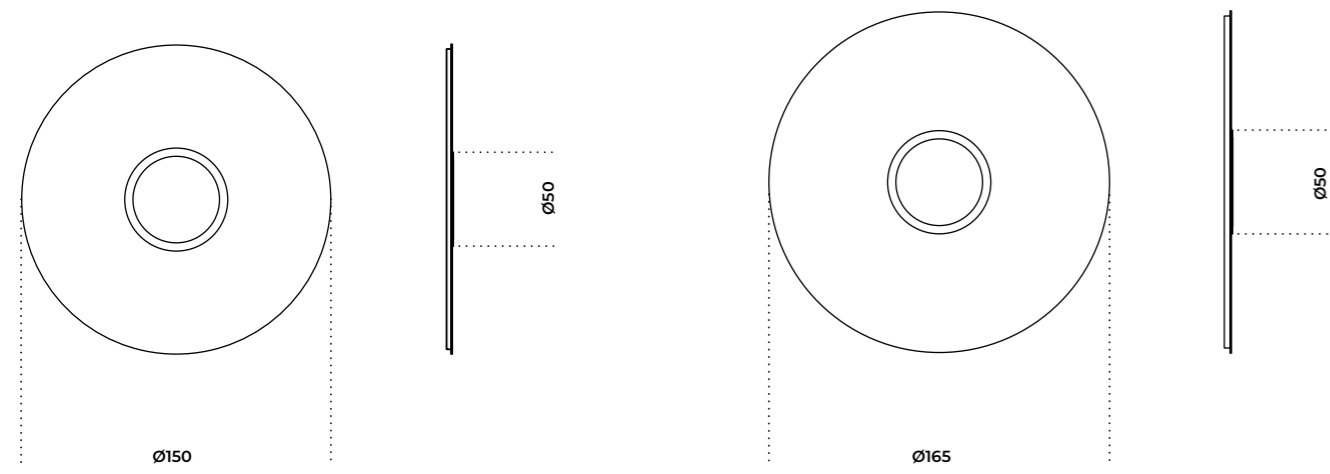

Zed | Ricardo Bello Dias, 2006

Product information / p. 594

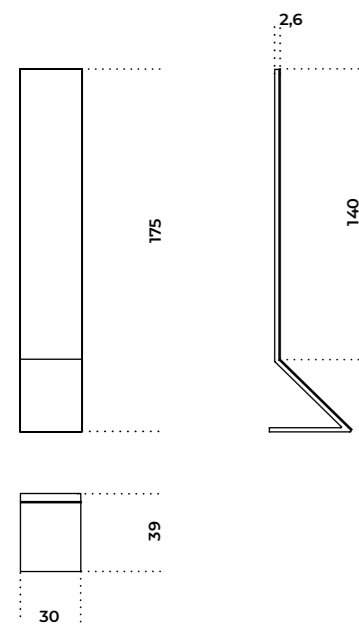

16 Elementi decorativi /
Decorative elements

608 [Lazy Susan](#)
610 [Leaf Sculpture](#)

612 [Informazioni tecniche /](#)
[Technical informations](#)

Lazy Susan

Studio G&R / 1986

Piano girevole in cristallo extralight 10mm molato a bisello (10mm) con parte centrale retroverniciata nei colori del campionario nella versione brillante. Disponibile versione completamente retroverniciata nei colori del campionario nella versione brillante o satinata. Può essere appoggiato su qualsiasi piano.

Rotating plate in 10mm extralight glass with bevelled edge (10mm). Painted glass central part as per sample in the bright version. Also available version completely painted as per samples in the bright or satin version. It can be placed on any top.

! Nella versione con parte centrale retroverniciata la retroverniciatura è realizzabile esclusivamente nella versione brillante.

! In the painted glass central part version the painting in the middle part can only be done in the bright version.



Cm	Inches
Ø 70	Ø 27¾"
Ø 75	Ø 29¾"
Ø 80	Ø 31½"
Ø 85	Ø 33½"
Ø 90	Ø 35½"
Ø 95	Ø 37½"
Ø 100	Ø 39½"

[For technical drawing / p. 614](#)

[Pricelist 2023 / p. 192](#)

PIANO GIREVOLE E PARTE CENTRALE ROTATING PLATE/CENTRAL PART



Cristallo extralight/Cristallo retroverniciato
brillante nei colori del campionario
Extralight glass/Bright
painted glass as per samples

PIANO GIREVOLE/ROTATING PLATE



Cristallo retroverniciato brillante/satinato
nei colori del campionario
Bright/satin painted glass
as per samples

• LAZY SUSAN
Piano girevole in cristallo extralight con parte centrale retroverniciato liquirizia brillante
Rotating plate in extralight glass with bright liquorice black painted central part

Leaf Sculpture

Ricardo Bello Dias / 2019

Sculpture in cristallo verniciate nella finitura metallo liquido color Avana e Lava. Montate su pannelli con diverse inclinazioni. Disponibili in composizioni predefinite. Strutture di collegamento in metallo laccato color brunito.

Sculptures in liquid metal lacquered glass in the colour Avana and Lava. Fixed on panels on different tilts. Available single or as per standard compositions. Burnished lacquered metal joint structure.

NOTE TECNICHE SUI MATERIALI

METALLO LIQUIDO | La componente metallica della vernice fa sì che durante l'applicazione il naturale procedimento di ossidazione crei disomogeneità di sfumature che conferiscono carattere ed unicità alla superficie. Il procedimento naturale viene accentuato attraverso l'utilizzo di acidi e la spazzolatura permette di ottenere i due diversi colori.

TECHNICAL INFORMATION ON THE MATERIALS

LIQUID METAL | The metallic component of the paint during the natural oxidation process creates uneven shades, that give uniqueness to the surface. The natural oxidation process is then enhanced by the use of acids and manual brushing to achieve the two different colours.

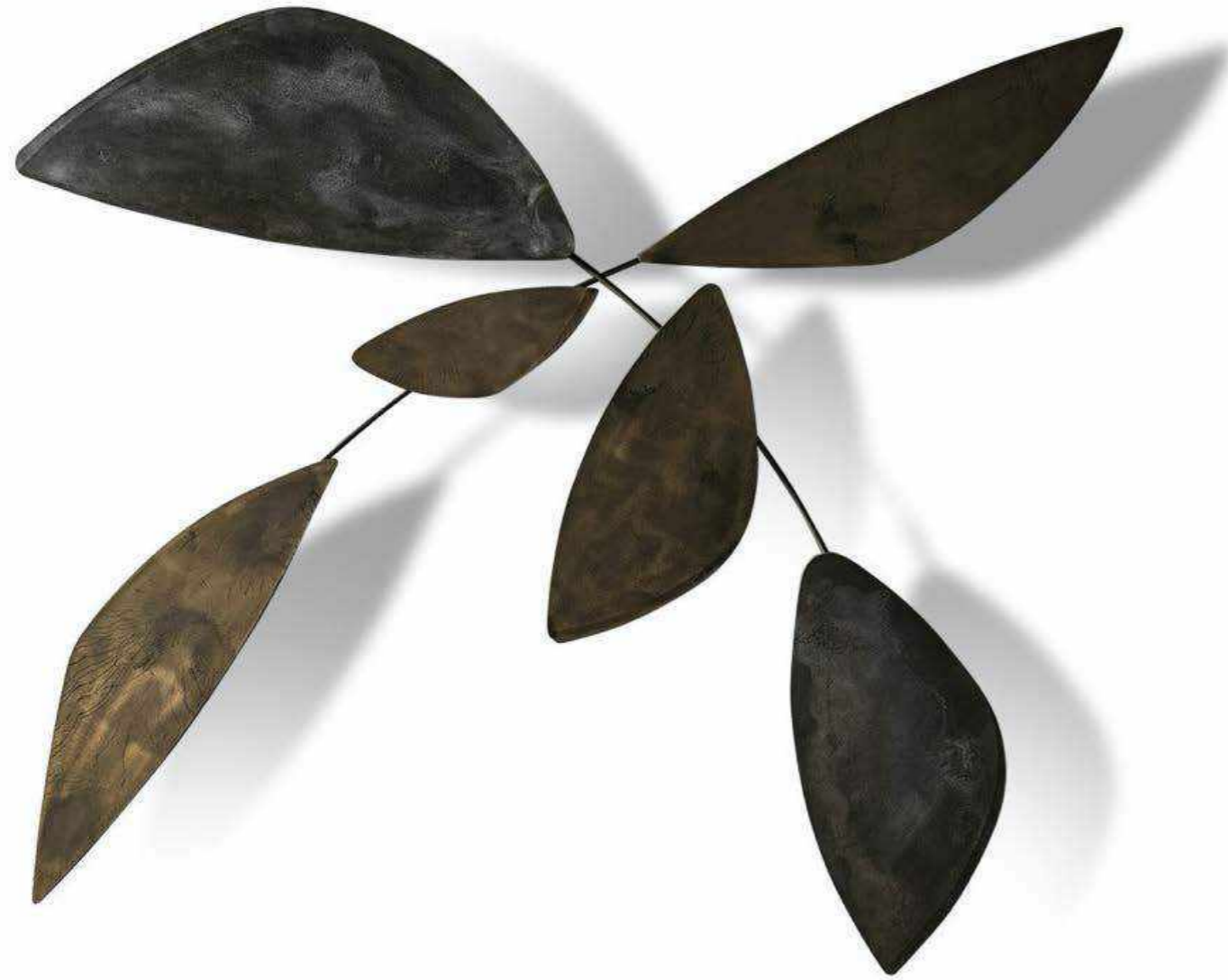

Cm
Composizione 1
215 x 200

Composizione 2
180 x 235

Inches
Composition 1
84¾" x 78¾"

Composition 2
71" x 92¾"

[For technical drawing / p. 614](#)

[Pricelist 2023 / p. 193](#)
[Homescapes, sense of materials / p. 38](#)

SCULTURE/SCULPTURES

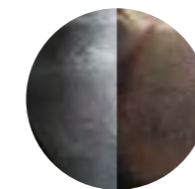

Cristallo verniciato
metallo liquido Avana e Lava
Liquid metal lacquered
Avana e Lava glass

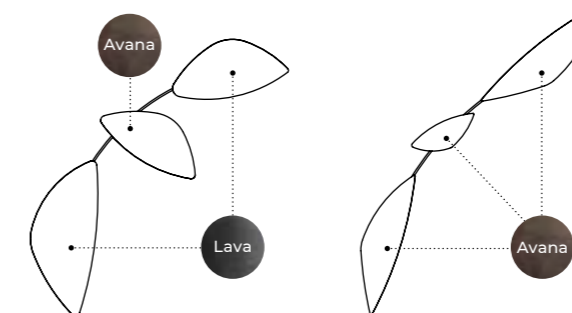

STRUTTURA/STRUCTURE

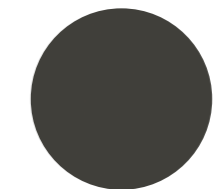

Metallo laccato
color brunito
Burnished lacquered metal

16

Elementi Decorativi / Decorative Elements
TECHNICAL MODULE

Lazy Susan | Studio G&R, 1986

Product information / p. 608

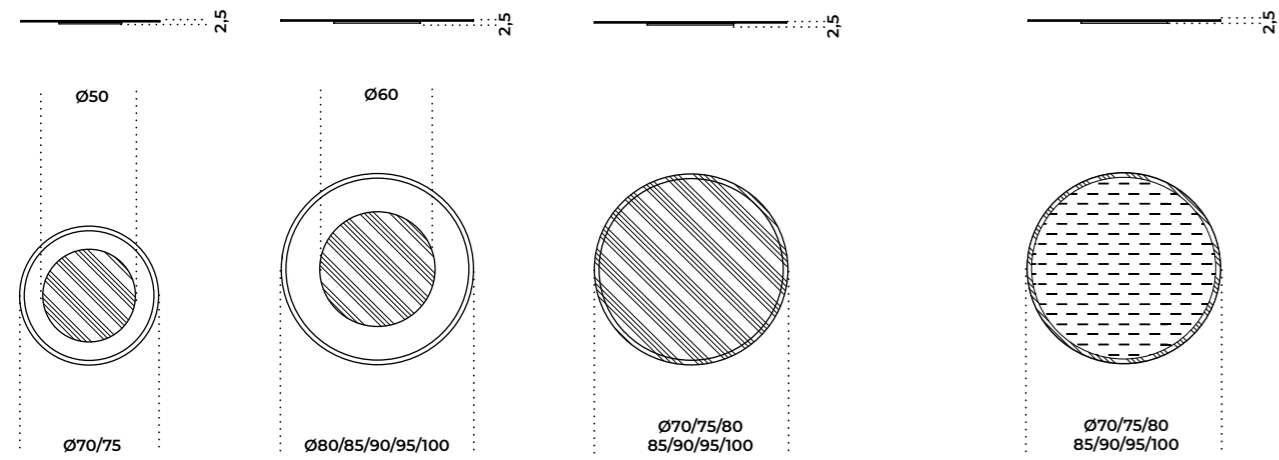

 **Cristallo retroverniciato brillante**
Bright painted glass

 **Cristallo retroverniciato satinato**
Satin painted glass

 **Cristallo retroverniciato brillante**
Bright painted glass

Leaf Sculpture | Ricardo Bello Dias, 2019

Product information / p. 510

Composizione 1
Composition 1

Composizione 2
Composition 2

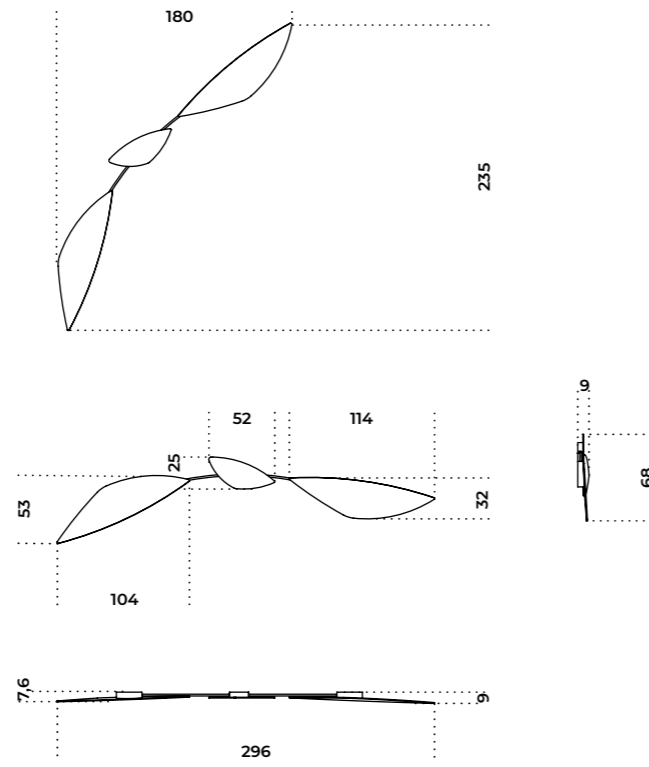
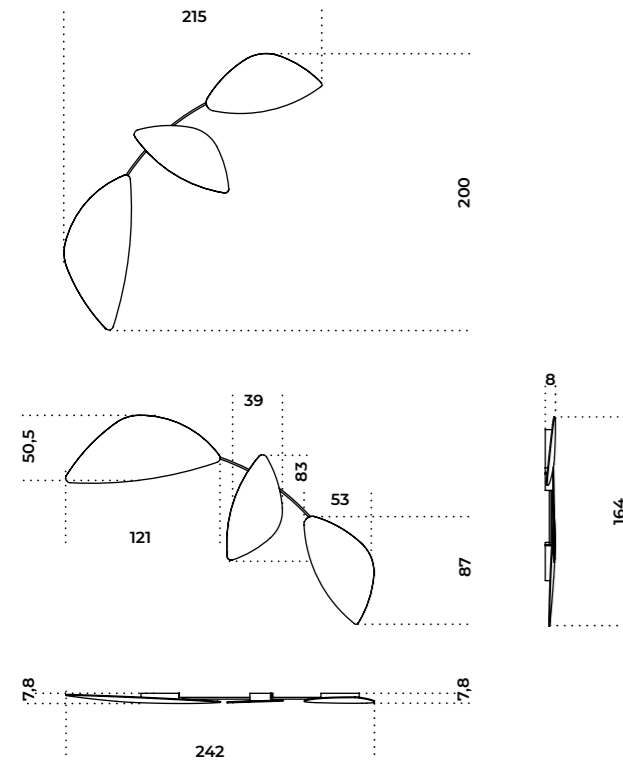

Combinazione 1 / Combination 1

Combinazione 2 / Combination 2

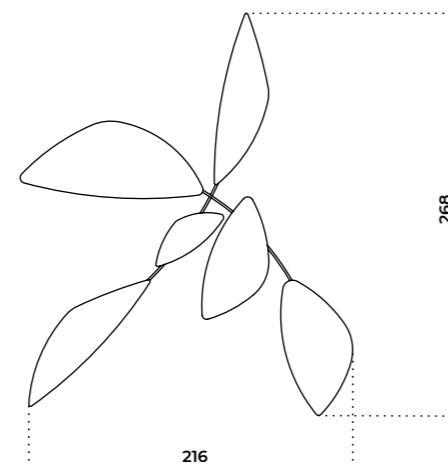
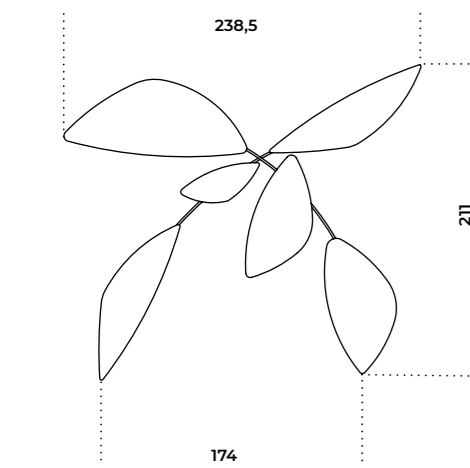

17 Tappeti /
Rugs

618 [Metaphores](#)

622 [Resia](#)

624 [Ruggy](#)

626 [Informazioni tecniche/
Technical informations](#)



▲ METAPHORES

Tappeto realizzato con: pelo corto beige e tessuto "Rigo" rosa "Dalia"
Rug made with: beige short pile and "Dalia" rose "Rigo" fabric

Metaphores

Studio G&R / 2023

Tappeto composto da una composizione di materiali realizzati con tecniche diverse: pelo corto, pelo lungo e tessuto "Rigo". Il tappeto a pelo corto è sempre realizzato nel colore beige, il tappeto a pelo lungo è sempre realizzato nel colore bianco. La parte in tessuto "Rigo" è tessuta e finita a mano e può essere realizzata in tre diversi colori: bianco "Conchiglia", rosa "Dalia" e grigio "Nuvola". L'unione degli diversi materiali è realizzata attraverso una termosaldatura.

Carpet composed of a composition of materials made with different techniques: short pile, long pile and "Rigo" fabric. The short pile carpet is always made in the color beige, the deep pile carpet is always made in the color white. The part in "Rigo" fabric is woven and finished by hand and can be made in three different colours: "Conchiglia" white, "Dalia" rose and "Nuvola" grey. The union of the different materials is achieved by heat-sealing.

! Eventuali variazioni cromatiche sono dovute alla lavorazione artigianale del tappeto.
! I colori potrebbero risultare di tonalità differenti da una partita all'altra.

! Any slight color variation is due to the craftsmanship.
! Colors can be different, if dye bath change.



Cm	Inches
A 432,5 x 420	170½" x 165½"
B 490 x 412,5	193" x 162½"
C 490 x 365	193" x 143¾"

[For technical drawing / p. 628](#)

[Pricelist 2023 / p. 195](#)
[Homescapes, embracing beauty / pp. 48, 82, 106](#)
[Homescapes, intimate portraits / p. 65](#)

PELO CORTO/SHORT PILE PELO LUNGO/DEEP PILE

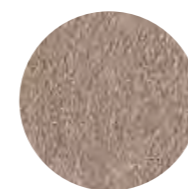

Beige
Beige

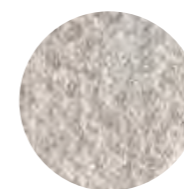

Bianco
White

TESSUTO "RIGO"/"RIGO FABRIC

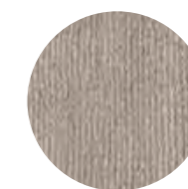

Bianco "Conchiglia"
"Conchiglia" white



Rosa "Dalia"
"Dalia" rose



Grigio "Nuvola"
"Nuvola" grey

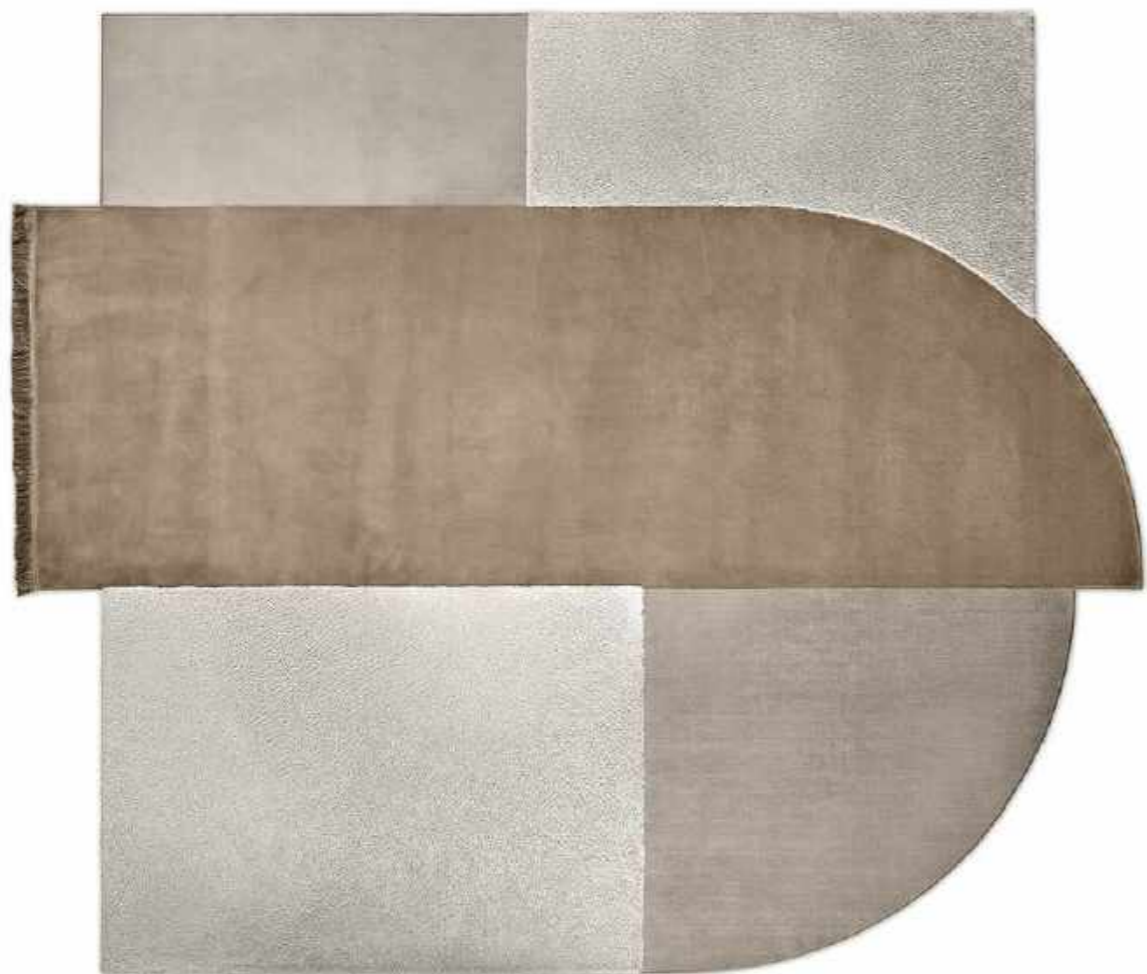

• METAPHORES

Tappeto realizzato con: pelo corto beige, pelo lungo bianco e tessuto "Rigo" bianco "Conchiglia"
Rug made with: beige short pile, white deep pile and "Conchiglia" white "Rigo" fabric

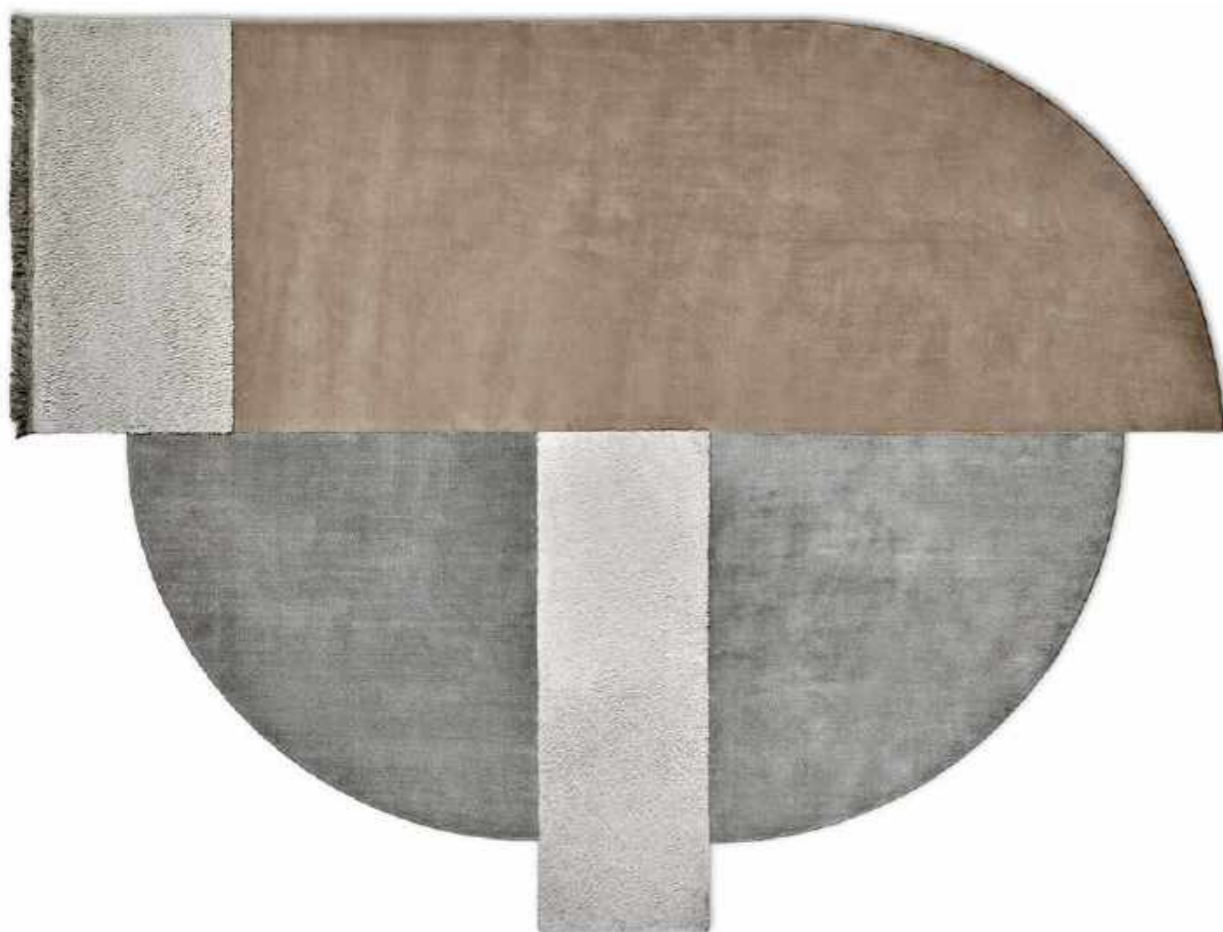

• METAPHORES

Tappeto realizzato con: pelo corto beige, pelo lungo bianco e tessuto "Rigo" grigio "Nuvola"
Rug made with: beige short pile, white deep pile and "Nuvola" grey "Rigo" fabric





• RESIA
Tappeto Tea Rose
Tea Rose rug

Resia

Dainelli Studio / 2021

Tappeto a pelo corto effetto velluto, piacevole sia per l'occhio che al tatto. Il disegno caratterizzante è costituito da elementi geometrici. L'unione degli elementi geometrici e il bordo perimetrale sono realizzati in filo in tinta. Disponibili nei colori Tea Rose, Amazing Grey e Simply White. La morbida fibra sintetica di cui è composto garantisce un'eccezionale praticità e una semplice manutenzione.

! I colori potrebbero risultare di tonalità differenti da una partita all'altra.
Le giunte tra due teli potrebbero risultare visibili.

Low pile rug with velvet effect, pleasant both to the eye and to the touch. The distinctive design consists of geometric elements. The joining of the geometric elements and the perimeter edge are made of matching yarn. Available in the colours Tea Rose, Amazing Grey and Simply White. The soft synthetic fibre of which it is composed guarantees an exceptional practicality and a simple maintenance.

! Colors can be different, if dye bath change.
Joints between two sheets may be visible.



Cm

400 x 350
400 x 500
450 x 260
560 x 400

Inches

157½" x 138"
157½" x 197"
177¼" x 102½"
220½" x 157½"

[For technical drawing / p. 629](#)

[Pricelist 2023 / p. 196](#)
[Homescapes, intimate portraits / p. 17](#)
[Homescapes, gentle attitude / pp. 41, 43, 92, 93](#)

VARIANTI COLORE/COLOR VARIANTS



Tea Rose



Amazing Grey



Simply White

Ruggy

Massimo Castagna / 2020

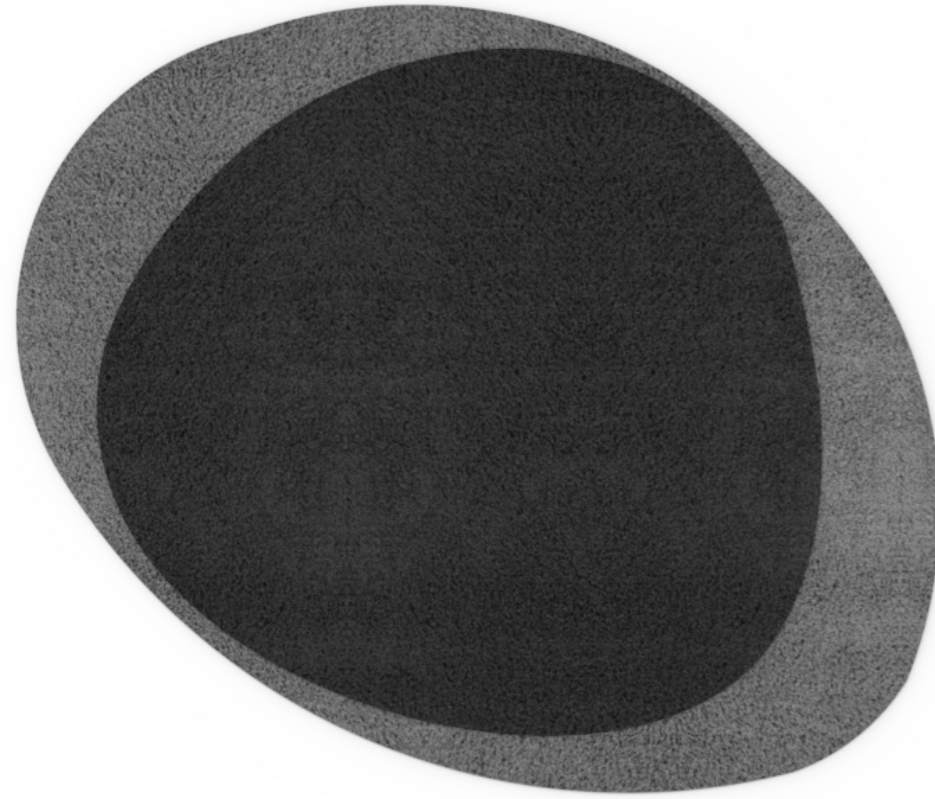

Tappeto bicolore a pelo alto in morbida fibra sintetica. Il vello è realizzato con la tecnica del tufting ed è molto morbido al tatto, con un marcato effetto scrivente. Il disegno caratterizzante è costituito da due forme organiche concentriche di differenti tonalità: ogni zona è termosaldata a quella vicina e ciò consente di non avere giunte visibili sulla superficie del tappeto. Il tappeto è bordato a filo, in tinta con le diverse aree di colore.

Disponibili in quattro combinazioni colore:
Beige 01 – interno bianco, esterno beige
Beige 02 – interno beige, esterno bianco

Grey 01 – interno grigio chiaro, esterno grigio scuro
Grey 02 – interno grigio scuro, esterno grigio chiaro

! I colori potrebbero risultare di tonalità differenti da una partita all'altra.
 Le giunte tra due teli potrebbero risultare visibili.

Two-tone deep pile rug in soft synthetic fiber. The pile is made using the tufting technic and is soft to the touch, with a strong marking effect. The distinctive design consists in two organic concentric shapes in different tones. These parts are heat sealed and this avoids visible joints on the rug's surface. The rug is flush edged in the same tone as the coloured areas. The natural colours offered and the iridescent nature of the fiber give character and refinement to every room.

Available in four colour combinations:
Beige 01 – white inside, beige outside
Beige 02 – beige inside, white outside

Grey 01 – light grey inside, dark grey outside
Grey 02 – dark grey inside, light grey outside

! Colors can be different, if dye bath change.
 Joints between two sheets may be visible.

▲ RUGGY

Tappeto bicolore combinazione Grey 02
 Two-tone rug in Grey 021 color combination

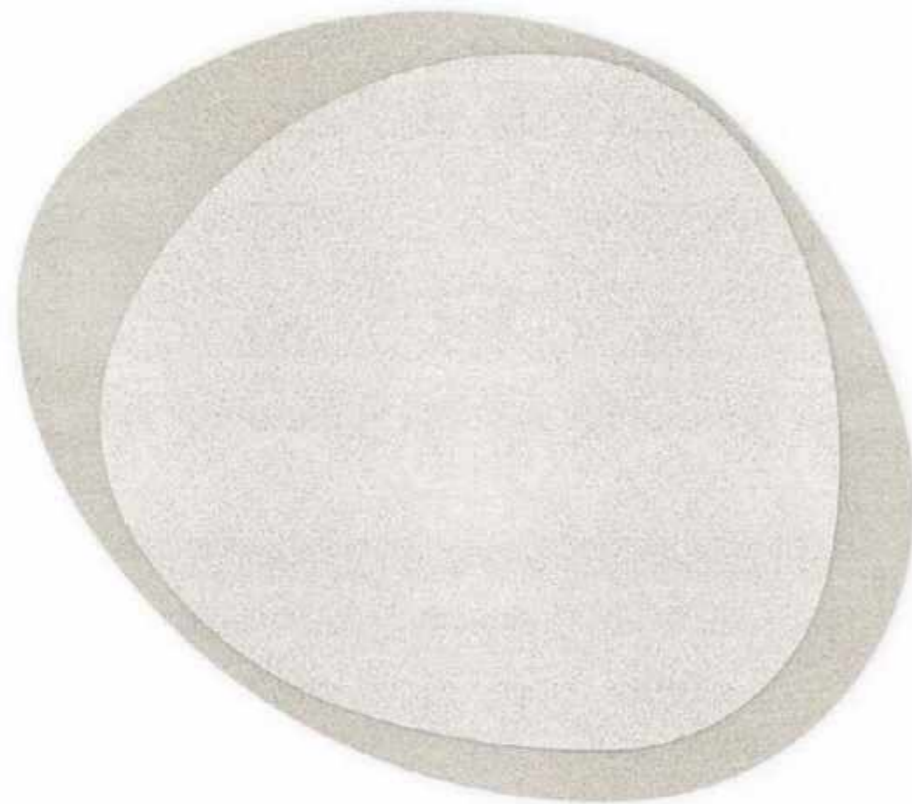

▲ RUGGY

Tappeto bicolore combinazione Beige 01
 Two-tone rug in Beige 01 color combination

Cm
 Ø 388 x 330
 Ø 455 x 400

Inches
 Ø 152¾" x 130"
 Ø 179¼" x 157½"

[For technical drawing / p. 630](#)

[Pricelist 2023 / p. 192](#)
[Homescapes, embracing beauty / pp. 48, 82, 106](#)
[Homescapes, intimate portraits / p. 65](#)

COMBINAZIONI COLORE/COLOUR COMBINATIONS



Beige 01



Beige 02

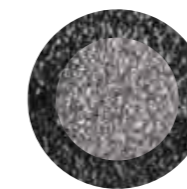

Grey 01

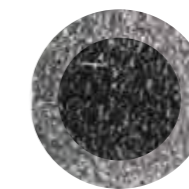

Grey 02

17

Tappeti / Rugs
TECHNICAL MODULE

Metaphores | Studio G&R, 2023

Product information / p. 618

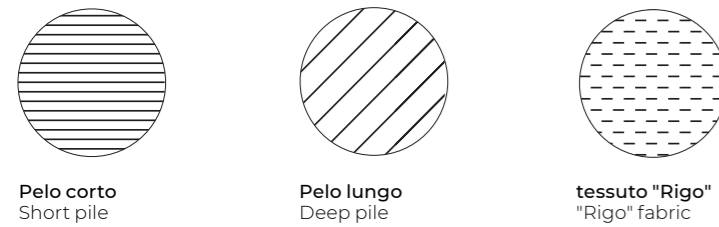
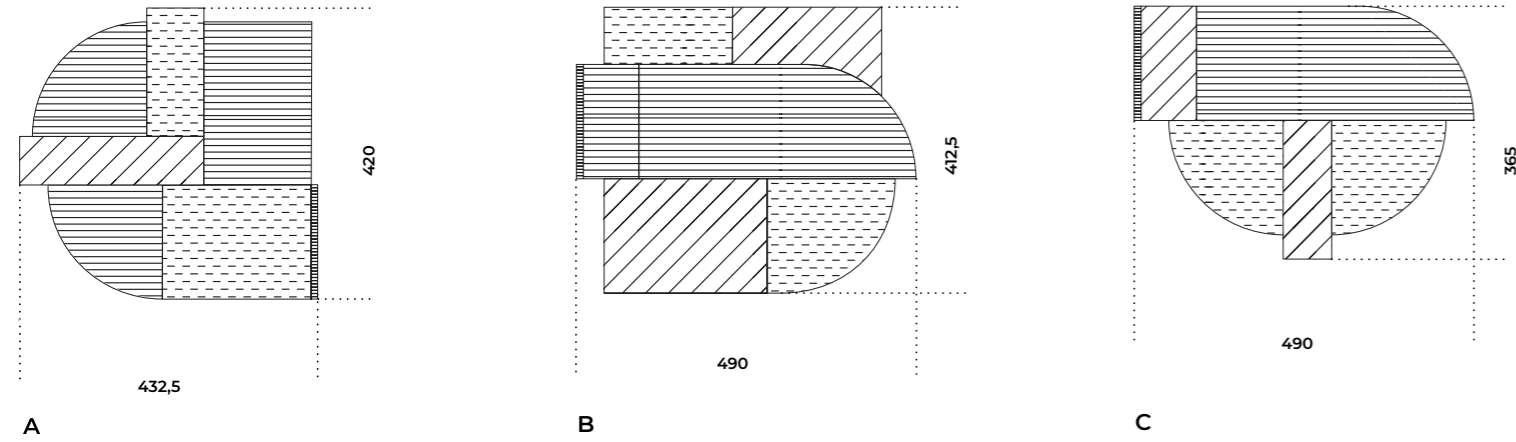

Dati tecnici: pelo corto

Costruzione	Plain saxony 5/64"
Composizione	100% PA IMPREL® Opal
Sottofondo	Twinback
Spessore totale	±12 mm
Peso totale	±2.600 gr/m ²
Numero di punti	±330.000/m ²
Altezza rotolo	±400 cm
Reazione al fuoco	Cfl - s1

Dati tecnici: pelo lungo

Costruzione	Berber Shaggy 1/8"
Composizione	100% PA IMPREL® Opal
Sottofondo	Twinback
Altezza pelo	±9,5 mm
Spessore totale	±13 mm
Peso felpa	±2.500 gr/m ²
Peso totale	±3.200 gr/m ²
Numero di punti	±98.000/m ²
Altezza rotolo	±400 cm
Reazione al fuoco	Cfl - s1

Dati tecnici: tessuto "Rigo"

Composizione	100% Polyamide 6.0
Sottofondo primario	Action Backing
Sottofondo secondario	Cotton Cloth
Larghezza rotolo	±400 cm
Peso pelo	±2.500 gr/m ²
Peso totale	±3.500 gr/m ²
Altezza pelo	±8 mm
Altezza totale	±11 mm
Reazione al fuoco	Cfl-S1
Zona di utilizzo	Class 32
Solidità alla luce	≥5
Indossabilità	≥5
Solidità all'acqua	≥5
TOG rating	1,14

Technical details: short pile

Construction	Plain saxony 5/64"
Composition	100% PA IMPREL® Opal
Backing	Twinback
Total height	±12 mm
Total weight	±2.600 gr/m ²
Tuft density	±330.000/m ²
Roll width	±400 cm
Flammability	Cfl - s1



Technical details: deep pile

Construction	Berber Shaggy 1/8"
Composition	100% PA IMPREL® Opal
Backing	Twinback
Pile height	±9,5 mm
Total height	±13 mm
Pile weight	±2.500 gr/m ²
Total weight	±3.200 gr/m ²
Tuft density	±98.000/m ²
Roll width	±400 cm
Flammability	Cfl - s1



Technical details: "Rigo" fabric

Composition	100% Polyamide 6.0
Primary backing	Action Backing
Secondary backing	Cotton Cloth
Roll width	±400 cm
Pile weight	±2.500 gr/m ²
Total weight	±3.500 gr/m ²
Pile height	±8 mm
Total height	±11 mm
Fire Classification	Cfl-S1
Use area	Class 32
Light fastness	≥5
Wearability	≥5
Water fastness	≥5
TOG rating	1,14



Resia | Dainelli Studio, 2021

Product information / p. 622

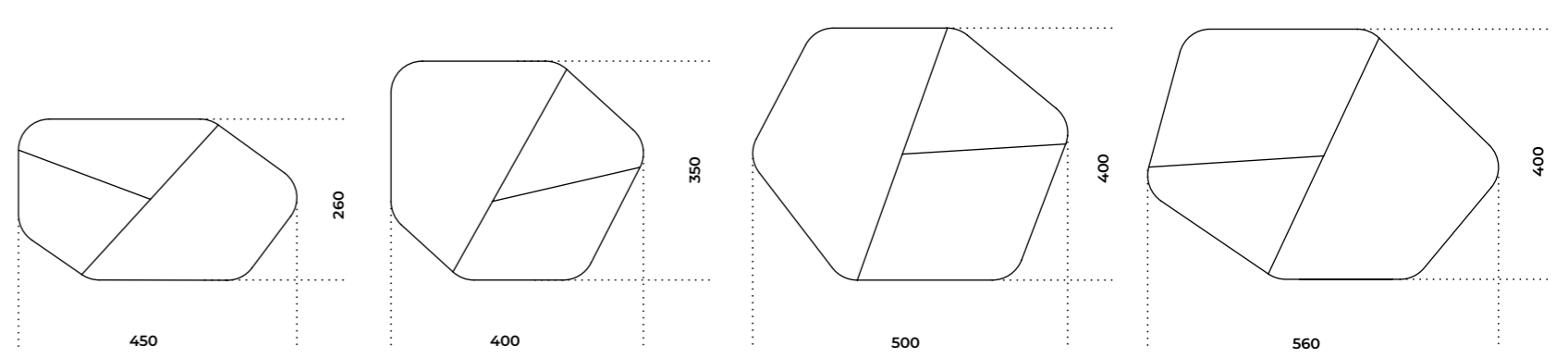

Dati tecnici

Aspetto	Velluto
Composizione	100% PA 6.6 Antron®
Costruzione	Tufting 1/10"
Peso felpa	1.950 gr/m ²
Peso totale	2.750 gr/m ²
Altezza felpa	9,00 mm
Altezza totale	11,4 mm
Punti inseriti	307.00/m ²
Colorazione	Tinto in Pezza
Sottofondo	Juta CB
Altezza rotoli	2-4 m
Lunghezza rotoli	25.30 m
Reazione al fuoco	Bfl - s1
Classe di resistenza	23-33
Riduzione del suono	ΔLw 25 dB
Conducibilità termica	0,15 m2 K/W

Technical details

Aspect	Cut Pile
Composition	100% PA 6.6 Antron®
Construction	Tufting 1/10"
Pile weight	1.950 gr/m ²
Total weight	2.750 gr/m ²
Pile thickness	9,00 mm
Total thickness	11,4 mm
Number of Tufts	307.00/m ²
Dyeing method	Continue
Backing	Action Back
Rolls width	2-4 m
Rolls length	25.30 m
Flammability	Bfl - s1
Resistance class	23-33
Impact sound reduction	ΔLw 25 dB
Thermal conductivity	0,15 m2 K/W

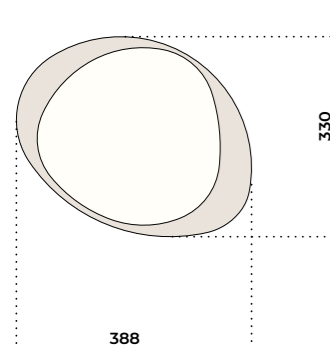

388

Small Beige 01

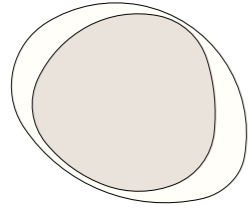

Small Beige 02

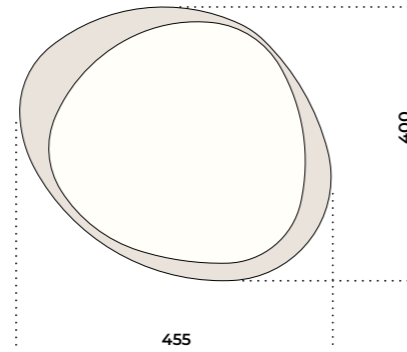

455

Big Beige 01

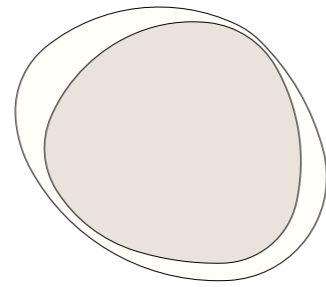

Big Beige 02

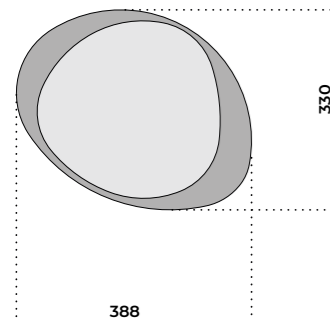

388

Small Grey 01

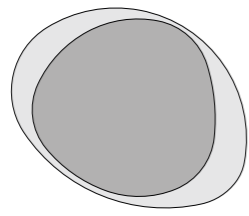

Small Grey 02

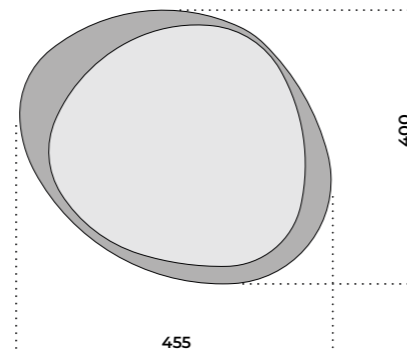

455

Big Grey 01

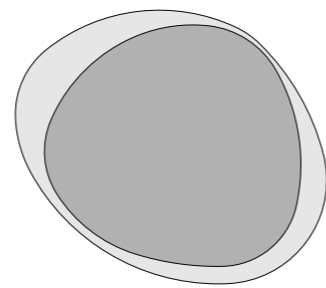

Big Grey 02

Dati tecnici

Costruzione	Tufting
Composizione	100% poliestere
Sottofondo	Geotessile satinato
Altezza pelo	±15
Altezza totale	±19
Peso totale	± 3.700 gr/m ²
Larghezza rotolo	400 cm
Reazione al fuoco	Cfl-s1

Technical details

Construction	Tufting
Composition	100% polyester
Backing	Satin geotextile
Pile height	±15
Total height	±19
Total weight	± 3.700 gr/m ²
Rolls width	400 cm
Flammability	Cfl-s1

18 Accessori /

Accessories

- [634](#) [Vase 1968](#)
- [636](#) [Candle Holder](#)
- [637](#) [Candle Holder Hexagonal](#)
- [638](#) [Desk Card Holder](#)
- [640](#) [Desk Set](#)
- [642](#) [Flabello](#)
- [644](#) [Folded Tray](#)
- [646](#) [Moonlight](#)
- [647](#) [Mouse Pad](#)
- [648](#) [Odette Tray](#)
- [650](#) [Paperweight](#)
- [652](#) [Pleiadi](#)
- [654](#) [Segno](#)
- [655](#) [Teddy](#)
- [656](#) [Tic Tac 14](#)
- [658](#) [Tip Tap Toe](#)

- [660](#) [Informazioni tecniche/
Technical informations](#)



Vase 1968

Silvia Gallotti / 2018

Vaso in ottone satinato e marmo levigato opaco Nero Marquinia o Calacatta Vagli Oro. Disponibile versione con due (M2) o tre marmi (M3). Riedizione del 1968.

NOTE TECNICHE SUI MATERIALI

MARMO | Il marmo è un materiale naturale di origine sedimentaria che può presentare particolarità come venature, lievi irregolarità superficiali, colorazioni differenti e cristallizzazioni. Queste disomogeneità sono da attribuirsi alla naturalezza del materiale e non sono da considerarsi difetti ma caratteristiche tipiche del marmo. Ogni prodotto risulterà unico, esclusivo e non replicabile.

Vase in satin brass and honed mat Nero Marquinia or Calacatta Vagli oro marble. Available version with two (M2) or three marbles (M3). Re-edition of 1968.

TECHNICAL INFORMATION ON THE MATERIALS

MARBLE | Il marmo è un materiale naturale di origine sedimentaria che può presentare particolarità come venature, lievi irregolarità superficiali, colorazioni differenti e cristallizzazioni. Queste disomogeneità sono da attribuirsi alla naturalezza del materiale e non sono da considerarsi difetti ma caratteristiche tipiche del marmo. Ogni prodotto risulterà unico, esclusivo e non replicabile.



	Cm	Inches
M2	10 x 10 x 23	4" x 4" x 9 1/4"
M3	10 x 10 x 23	4" x 4" x 9 1/4"

For technical drawing / p.662

Pricelist 2023 / p.314

STRUTTURA



Ottone satinato/
Marmo levigato opaco
Nero Marquinia
Satin brass/ Honed mat
Nero Marquinia marble



Ottone satinato/
Marmo levigato opaco
Calacatta Vagli Oro
Satin brass/ Honed mat
Calacatta Vagli Oro marble

Candle Holder

Studio G&R / 2014

Porta candele in ottone massiccio lucido. Set di due pezzi.

Candle holders in solid bright brass. Set of two.



Cm
Ø3 x 4 x 20

Inches
Ø1" x 1¼" x 8"

[For technical drawing / p.662](#)
[Pricelist 2023 / p.315](#)

STRUTTURA/STRUCTURE

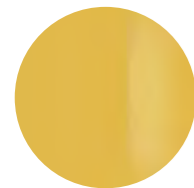

Ottone lucido
Bright brass

Candle Holder Hexagonal

Studio G&R / 2014

Porta candele esagonali in ottone massiccio lucido all'esterno e opaco all'interno. Set di tre pezzi.

Hexagonal candle holders in solid bright brass outside and opaque brass inside. Set of three.

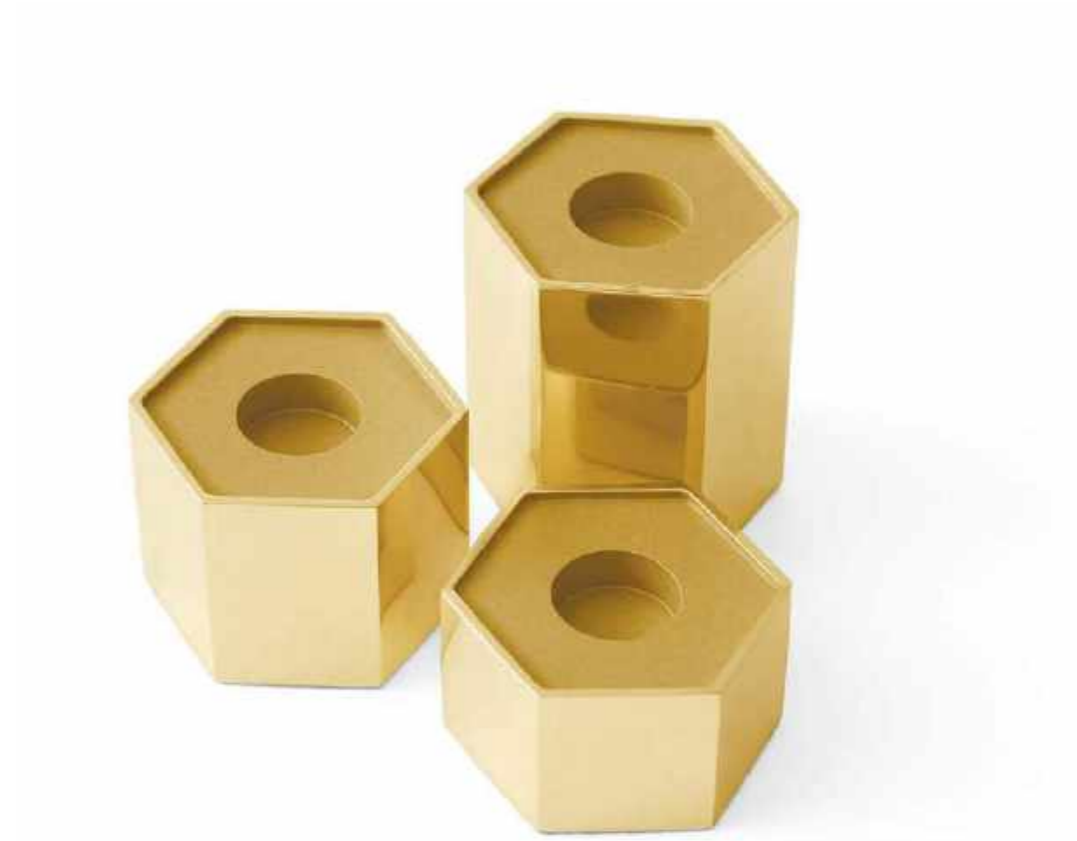

Cm
Ø5 x 5 x 6

Inches
Ø 2" x 2" x 2½"

[For technical drawing / p.662](#)
[Pricelist 2023 / p.316](#)

STRUTTURA/STRUCTURE

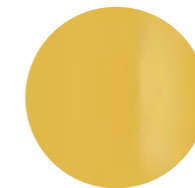

Ottone lucido
Bright brass



Desk Card Holder

Studio G&R / 2014

Porta biglietti da visita in ottone massiccio lucido.

Desk card holder in solid bright brass.



Cm
Ø 7 x 4

Inches
Ø 3" x 1 1/4"

[For technical drawing / p.663](#)

[Pricelist 2023 / p.317](#)

STRUTTURA/STRUCTURE

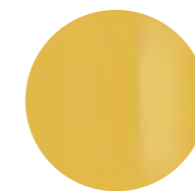

Ottone lucido
Bright brass



Desk Set

Silvia Gallotti / 2019

Organizer da scrivania in ottone satinato con tre elementi in appoggio: un portabiglietti in marmo Verde Alpi spazzolato, un calendario in frassino tinto nero poro aperto e un portapenne in cristallo trasparente da 24mm.

Desk organizer in satin brass with three freestanding elements: a business card holder in Verde Alpi brushed marble, a calendar in black stained open pore ash and a 24mm pen holder in transparent glass.

NOTE TECNICHE SUI MATERIALI

MARMO | Il marmo è un materiale naturale di origine sedimentaria che può presentare particolarità come venature, lievi irregolarità superficiali, colorazioni differenti e cristallizzazioni. Queste peculiarità sono da attribuirsi alla naturalezza del materiale e non sono da considerarsi difetti ma caratteristiche tipiche del marmo. Ogni prodotto risulterà unico, esclusivo e non replicabile.

TECHNICAL INFORMATION ON THE MATERIALS

MARBLE | The marble is a natural material of sedimentary origin that can present particularities such as veins, slight surface irregularities, different colors and crystallizations. These peculiarities are to be attributed to the naturalness of the material and are not to be considered defects but typical characteristics of marble. Each product will be unique, exclusive and non-replicable.



Cm
27 x 9,3 x 3,6

Inches
10¾" x 3¾" x 1½"

For technical drawing / p.663

Pricelist 2023 / p. 318

STRUTTURA/STRUCTURE



Ottone satinato
Satin brass

PORTABIGLIETTI/ BUSINESS CARD HOLDER

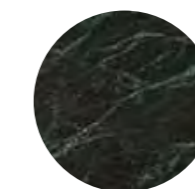

Marmo Verde Alpi
spazzolato
Verde Alpi brushed
marble

CALENDARIO/CALENDAR

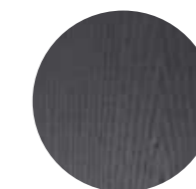

Frassino tinto
nero poro aperto
Black stained
open pore ash

PORTA PENNE/PEN HOLDER



Cristallo trasparente
Transparent glass



Flabello

Lanzavecchia + Wai / 2017

Specchio da tavolo 4mm, argentato ed anticato a mano.
Base in frassino tinto nero poro aperto e ottone lucido.

4mm hand silver-plated and antiqued table mirror.
Black open pore stained ash wooden base and bright brass.

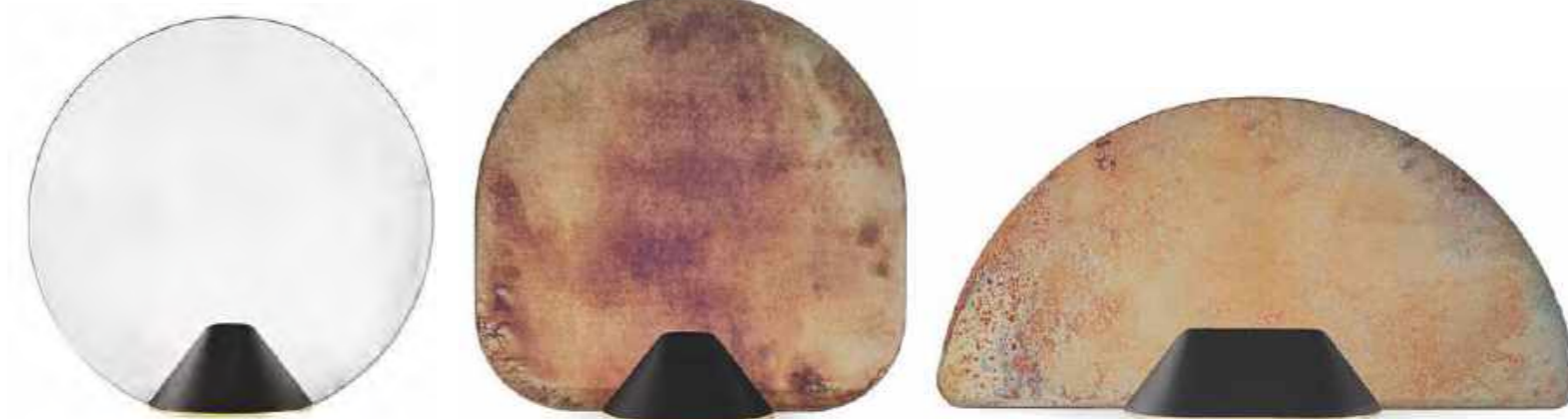

	Cm	Inches
S	32 x 10 x 30	12 ³ / ₄ " x 4" x 12"
M	40 x 15 x 38	15 ³ / ₄ " x 6" x 15"
L	50 x 10 x 25	19 ³ / ₄ " x 4" x 10"

For technical drawing / p.663

Pricelist 2023 / p.319

SPECCHIO/MIRROR



Specchio argentato-
anticato a mano
Hand silver-
plated and antiqued mirror

BASE/BASE

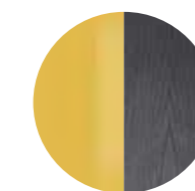

Frassino tinto nero poro aperto/
Ottone lucido
Black stained open pore ash/
Bright brass

Folded Tray

Studio G&R / 2014

Vassoio in ottone satinato e specchio anticato, disponibile nella finitura "Antique 1" o "Antique 2". A richiesta anche in ottone argentato satinato.

Tray in satin brass and antiqued mirror available in the "Antique 1" or "Antique 2" finish. Satin silver-plated brass, on request.



▲ FOLDER TRAY
Piano in specchio "Antique 1" / Lati e base in ottone satinato
"Antique 1" mirror top / Satin brass sides and base



Cm
26 x 35,5 x 6

Inches
10 3/4" x 14" x 2 1/2"

[For technical drawing / p.664](#)

[Pricelist 2023 / p.320](#)

LATI E BASE/SIDES AND BASE



Ottone satinato
Satin brass



Ottone satinato argentato
Satin silver-plated brass

PIANO/TOP



Specchio "Antique 1"
"Antique 1" mirror



Specchio "Antique 2"
"Antique 2" mirror

Moonlight

Silvia Gallotti / 2017

Set di 6 sottopiatte in cristallo 4mm decorato a mano. Sfumature nei toni del nero e nichel sul fronte e nichel satinato spazzolato incrociato sul retro.

NOTE TECNICHE SUI MATERIALI

CRISTALLO | Le finiture esclusive risultato del processo di lavorazione manuale realizzata sul cristallo possono presentare macchie e striature, oltre a differenze cromatiche.

Tali disomogeneità sono caratteristiche che non devono essere considerate difetti ma elementi distintivi che esaltano la bellezza e la peculiarità del pezzo unico.

Table set made of 6 charger plates in 4mm hand decorated glass. On the front black and nickel colours shades, on the back satin nickel hand brushed with woven pattern.

TECHNICAL INFORMATION ON THE MATERIALS

GLASS | Artisanal and exclusive finishes that are obtained from the oxidation of silver, gold and copper leaves may show marks and spots, as well as variations in colour. These differences are inevitable and should not be considered imperfections but evidence of the hand-crafted process. They enhance the beauty and distinctiveness of a unique piece.

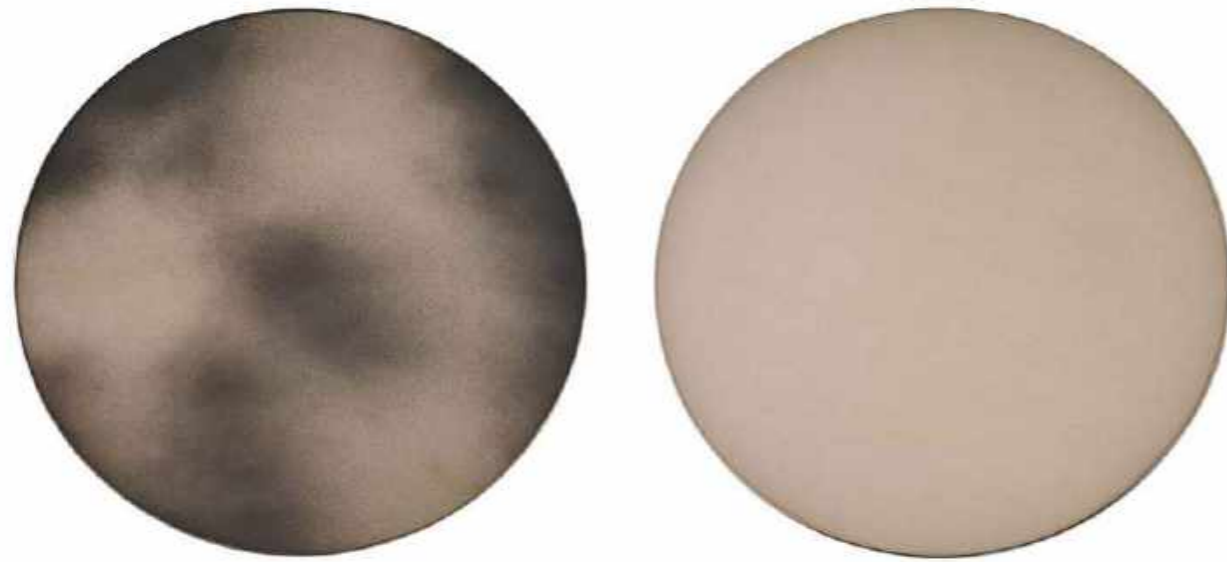

Cm
Ø 33

Inches
Ø 13"

[For technical drawing / p.664](#)

Pricelist 2023 / p.321

FRONTE/FRONT



**Cristallo sfumato
nero e nichel**
Glass with shades in
black and nichel colours

RETRO/BACK



**Cristallo nichel satinato
spazzolato incrociato**
Satin nickel hand brushed
glass with woven pattern

Mouse Pad

Studio G&R / 2009

Mouse pad in cristallo retroverniciato satinato nei colori del campionario. Logo Gallotti&Radice serigrafato sul bisello.

Satin painted glass mouse pad as per samples. Gallotti&Radice screen printed logo on the bevel.



Cm
23 x 23

Inches
9 1/4" x 9 1/4"

[For technical drawing / p.664](#)

Pricelist 2023 / p.322

STRUTTURA/STRUCTURE



**Cristallo retroverniciato
satinato nei colori del
campionario**
Satin painted glass as
per samples

Odette Tray

Studio G&R / 2014

Vassoio in specchio anticato disponibile nella finitura "Antique 1" o "Antique 2".
Supporto in metallo ottonato lucido.

Tray in antiqued mirror available in the "Antique 1" or "Antique 2" finish.
Bright brass-plated metal support.



Cm
38,5 x 30 x 4
50 x 26,5 x 4

Inches
15¼" x 12" x 1¾"
19¾" x 10½" x 1¾"

For technical drawing / p. 665

Pricelist 2023 / p. 323

VASSOIO/TRAY



Specchio "Antique 1"
"Antique 1" mirror



Specchio "Antique 2"
"Antique 2" mirror

SUPPORTO/SUPPORT

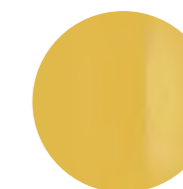

Metallo ottonato
Brassed metal

• ODETTE TRAY
Specchio "Antique 2" / Supporto in metallo ottonato
"Antique 2" mirror / Brass-plated metal support



Paperweight

Studio G&R / 2014

Fermacarte in ottone massiccio lucido. Disponibile in tre versioni.

Paperweight in solid bright brass. Available in three versions.



Cm
Ø12 x 1

Inches
Ø4¾" x ½"

[For technical drawing / p.665](#)

[Pricelist 2023 / p.324](#)

STRUTTURA/STRUCTURE

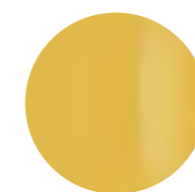

Ottone lucido
Bright brass



Pleiadi

Sutdiopepe/2023

Rivestimento decorativo realizzato in linters di cotone e argille e ottenuto tramite un processo di lavorazione artigianale a freddo. Può essere posizionato sia orizzontalmente che verticalmente per creare diverse composizioni e effetti grafici. Disponibile nel colore "nature". Trattandosi di un prodotto realizzato artigianalmente e manualmente, la dimensioni potrebbero variare leggermente.

Decorative wallcovering made of cotton linters and clays and obtained through a cold craft process. Can be placed both horizontally and vertically to create different compositions and graphic effects. Available in 'nature' colour. As this is a handcrafted and manually made product, the dimensions may vary slightly.

NOTE TECNICHE SUI MATERIALI

FINITURE ARTIGIANALI | Le finiture manuali ed esclusive risultato del processo di ossidazione di foglia argento, oro e rame possono presentare macchie e striature, oltre a differenze cromatiche. Tali disomogeneità sono caratteristiche che non devono essere considerate difetti ma elementi distintivi, tipici dell'ossidazione manuale, che esaltano la bellezza e la peculiarità del pezzo unico.

TECHNICAL INFORMATION ON THE MATERIALS

ARTISANAL FINISHES | Artisanal and exclusive finishes that are obtained from the oxidation of silver, gold and copper leaves may show marks and spots, as well as variations in colour. These differences are inevitable and should not be considered imperfections but evidence of the hand-crafted process. They enhance the beauty and distinctiveness of a unique piece.



Cm
20 x 3 x 20

Inches
8" x 1¼" x 8"

For technical drawing / p. 665

Pricelist 2023 / p. 325



"Nature"

Segno

Elisa Ossino / 2018

Segnalibro in ottone satinato. Set di due pezzi.

Satin brass bookmark. Set of two.



Cm
Ø6,5
3,5 x 8

Inches
Ø2¾"
1½" x 3¼"

[For technical drawing / p.666](#)

[Pricelist 2023 / p.326](#)

STRUTTURA/STRUCTURE



Ottone satinato
Satin brass

Teddy

Studio G&R / 2023

Cuscino decorativo rivestito in pregiata pelliccia ecologica piacevole al tatto e dotata di un pelo fitto. Disponibile nei colori: thrill silver 701, thrill ecru 901, thrill blueberry 001 e thrill silt 101.

Decorative cushion covered by finest faux furs pleasant to the touch and with a dense pile. Available in the colours: thrill silver 701, thrill ecru 901, thrill blueberry 001 and thrill silt 101.



Cm
Ø38
40 x 40
60 x 60
35 x 25
70 x 38

Inches
Ø15
15¾" x 15¾"
23¾" x 23¾"
14" x 10"
27¾" x 1"

[For technical drawing / p.666](#)

[Pricelist 2023 / p.327](#)

RIVESTIMENTO/COVER



Pelliccia ecologica
Thrill silver 701
Faux furs
Thrill silver 701



Pelliccia ecologica
Thrill ecru 901
Faux furs
Thrill ecru901



Pelliccia ecologica
Thrill blueberry 001
Faux furs
Thrill blueberry 001



Pelliccia ecologica
Thrill silt 101
Faux furs
Thrill silt 101



▲ **TIC TAC 14**
Struttura in frassino tinto tabacco
Tobacco stained ash structure

Tic Tac 14

Studio G&R/2014

Orologio a pendolo con caricamento manuale. Struttura in frassino tinto tabacco o nero poro aperto. Frontale in cristallo extralight 6mm bisellato. Fondo in acciaio inox lucido "supermirror". Meccanismo in alluminio anodizzato nero e ottone cromato. Orologio con funzione a batteria. Su richiesta, incisione personalizzata sulla ghiera in acciaio inox.

! Per incisione necessario file dwg.

Manual winding pendulum clock. Tobacco stained or black open pore stained ash structure and 6mm extralight bevelled front glass. "Supermirror" bright stainless steel back. Black anodised aluminium and chromed brass mechanism. Striking mechanism clock. Customized engraving on the bright stainless steel ring, on request.

! For engraving dwg file required.



Cm
Ø50 x 20 x 175

Inches
Ø19¾" x 8" x 69"

[For technical drawing / p. 666](#)

[Pricelist 2023 / p. 203](#)

STRUTTURA/STRUCTURE

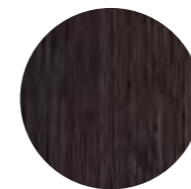

Frassino tinto tabacco
Tobacco open pore
stained ash

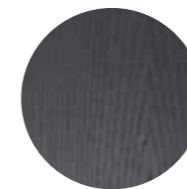

Frassino tinto
nero poro aperto
Black open pore
stained ash

FRONTALE/FRONT



Cristallo extralight
Extralight mirror

FONDO/BACK



Acciaio Inox lucido
Bright stainless steel

MECCANISMO/ MECHANISM

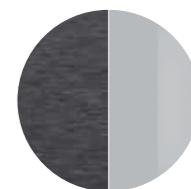

Alluminio anodizzato nero/
ottone cromato
Black anodised aluminium/
chromed brass



Tip Tap Toe

Silvia Gallotti / 2017

Gioco da tavolo in marmo lucido naturale Nero Marquinia e ottone massiccio. Pedine in ottone lucido e satinato.

Table game in natural polished Nero Marquinia marble and solid brass. Pawns in bright and satin brass.

NOTE TECNICHE SUI MATERIALI

MARMO | Il marmo è un materiale naturale di origine sedimentaria che può presentare particolarità come venature, lievi irregolarità superficiali, colorazioni differenti e cristallizzazioni. Queste disomogeneità sono da attribuirsi alla naturalezza del materiale e non sono da considerarsi difetti ma caratteristiche tipiche del marmo. Ogni prodotto risulterà unico, esclusivo e non replicabile.

TECHNICAL INFORMATION ON THE MATERIALS

MARBLE | Il marmo è un materiale naturale di origine sedimentaria che può presentare particolarità come venature, lievi irregolarità superficiali, colorazioni differenti e cristallizzazioni. Queste disomogeneità sono da attribuirsi alla naturalezza del materiale e non sono da considerarsi difetti ma caratteristiche tipiche del marmo. Ogni prodotto risulterà unico, esclusivo e non replicabile.

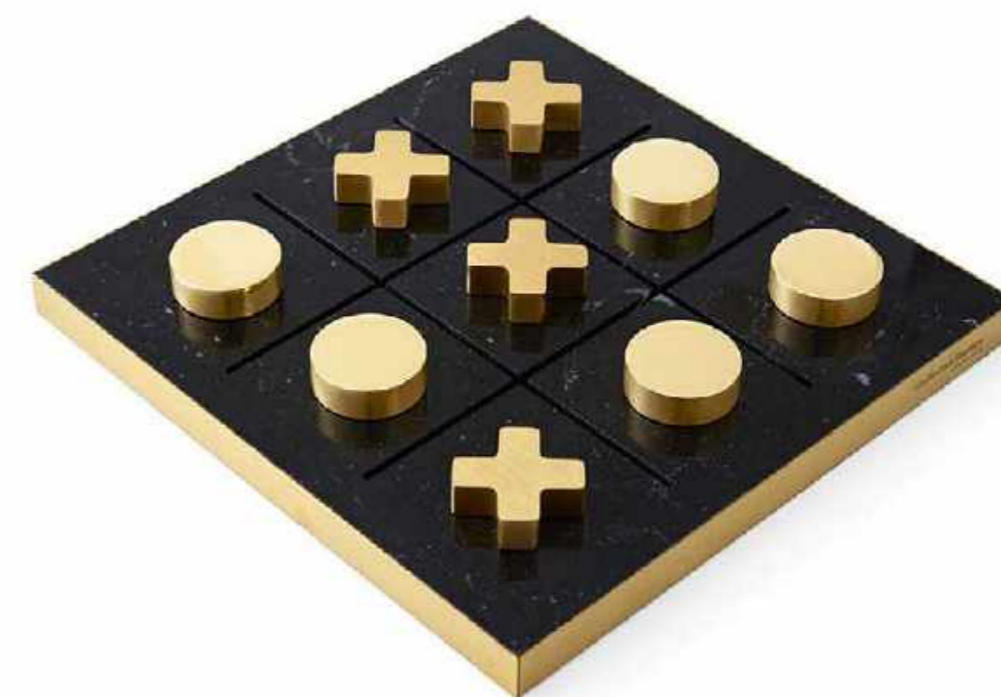

Cm
28 x 28 x 4

Inches
11¼" x 11¼" x 1¼"

[For technical drawing / p. 667](#)

[Pricelist 2023 / p. 328](#)

BASE/BASE



Marmo lucido naturale
Nero Marquinia/
Ottone satinato
Natural polished
Nero Marquinia marble/
Satin brass

PEDINE/ PAWNS



Ottone lucido
Bright brass



Ottone satinato
Satin brass

18

Accessori / Accessories
TECHNICAL MODULE

Vase | Silvia Gallotti, 2018

Product information / p. 634

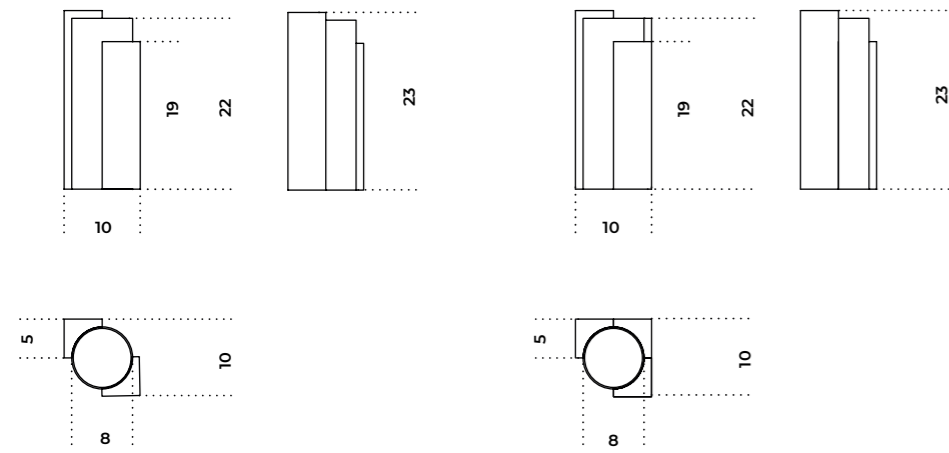

M2

M3

Candle Holder | Studio G&R, 2014

Product information / p. 636

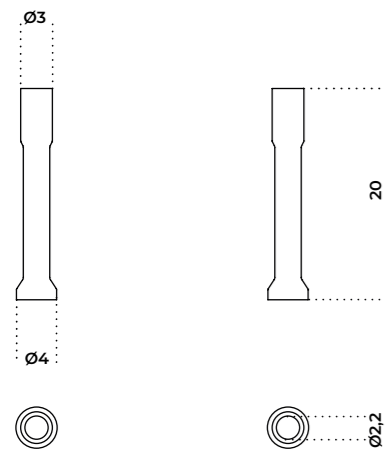

Candle Holder Hexagonal | Studio G&R, 2014

Product information / p. 637

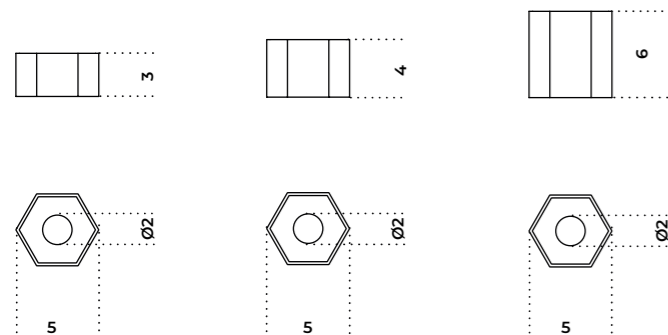

Desk Card Holder | Studio G&R, 2014

Product information / p. 638

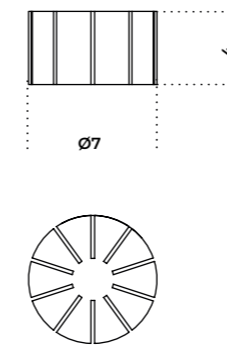

Desk Set | Silvia Gallotti, 2019

Product information / p. 640

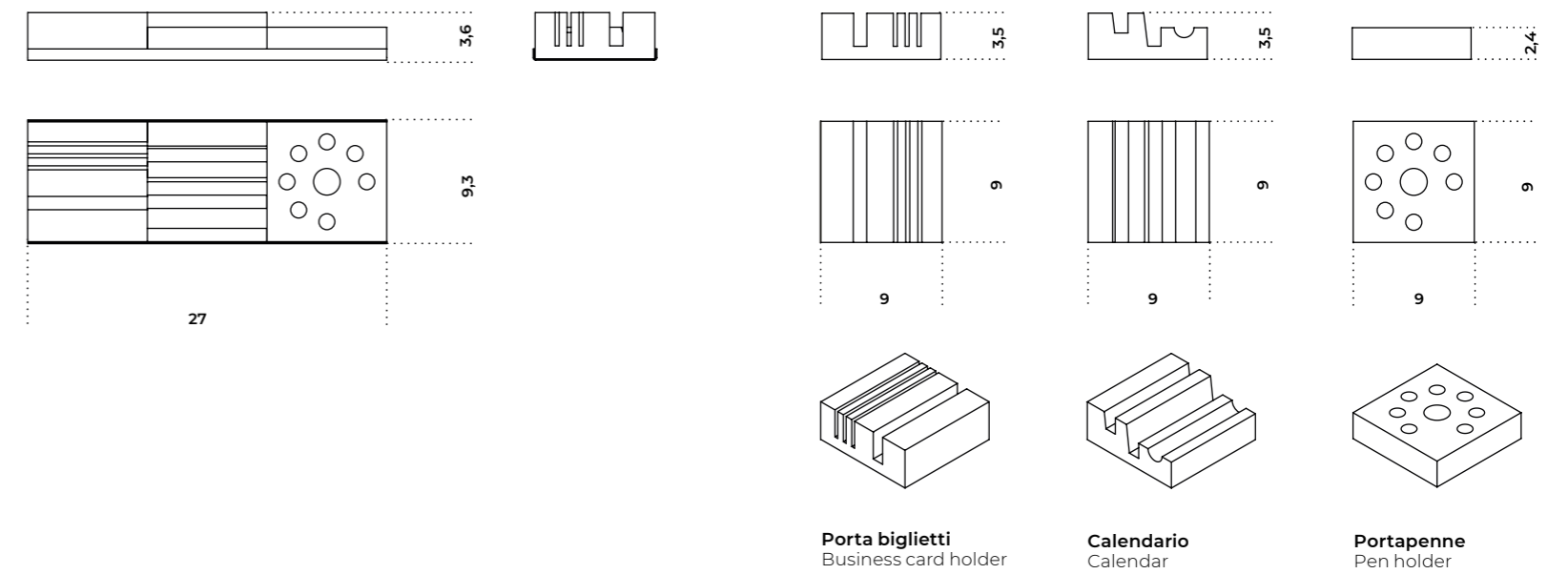

Fiabello | Lanzavecchia + Wai, 2017

Product information / p. 642

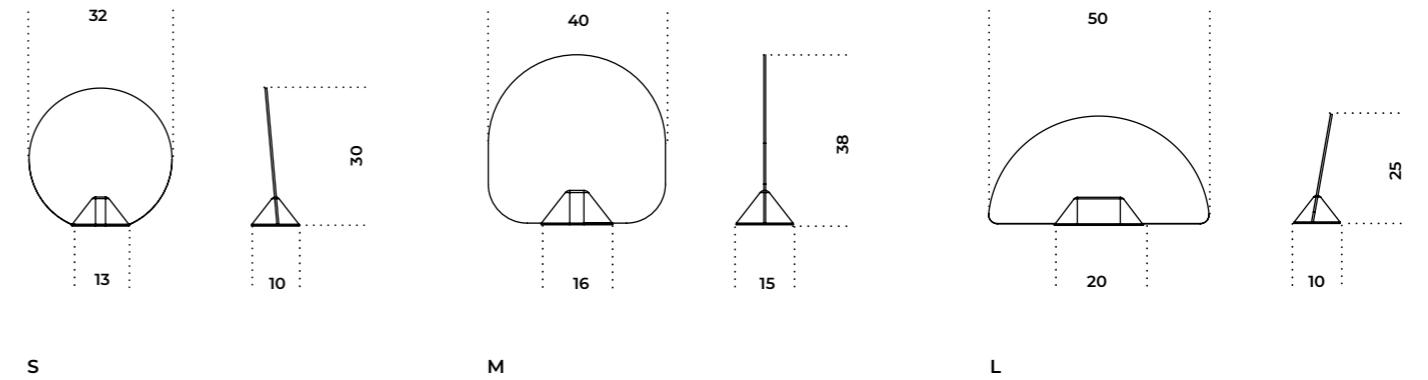

Folded Tray | Studio G&R, 2014

Product information / p.644

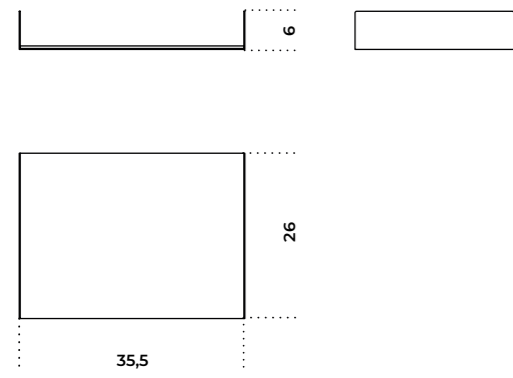

Odette Tray | Studio G&R, 2014

Product information / p.648

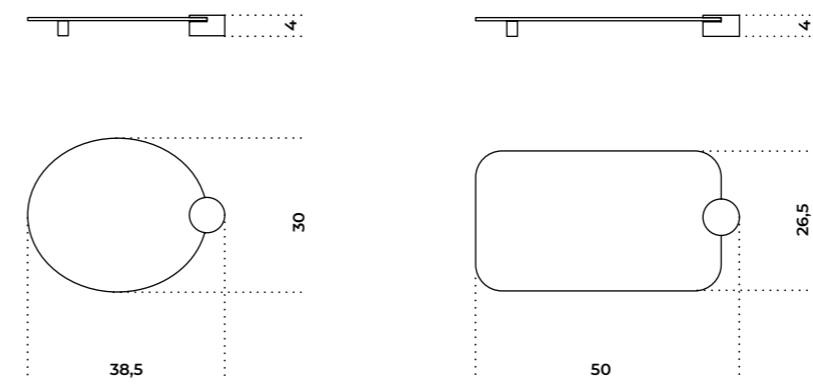

Moonlight | Silvia Gallotti, 2017

Product information / p.646

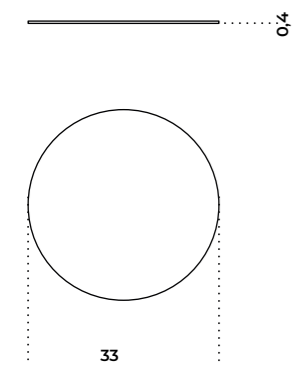

Paperweight | Studio G&R, 2014

Product information / p.650

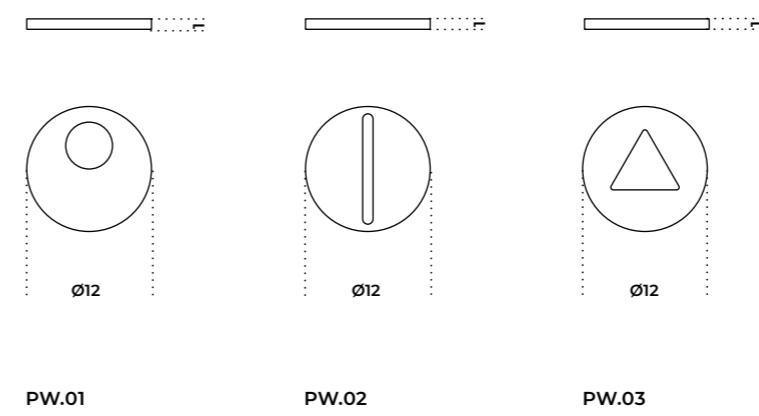

Mouse Pad | Studio G&R, 2009

Product information / p.647

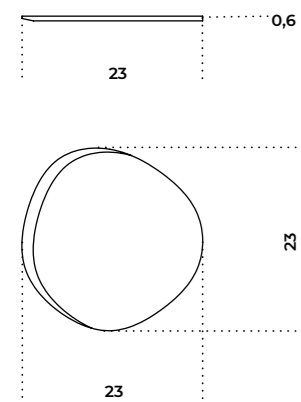

Pleiadi | Studiopepe, 2023

Product information / p.652

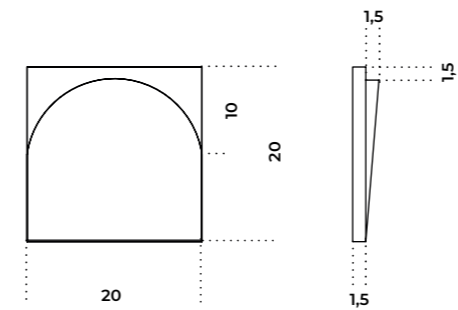

Segno | Elisa Ossino, 2018

Product information / p. 654

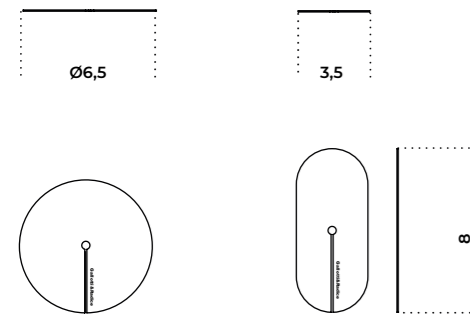

Tip Tap Toe | Silvia Gallotti, 2017

Product information / p. 658

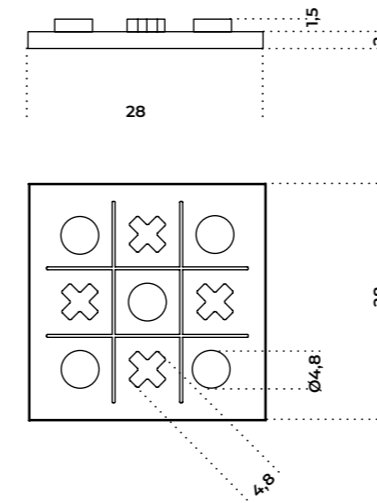

Teddy | Studio G&R, 2023

Product information / p. 655

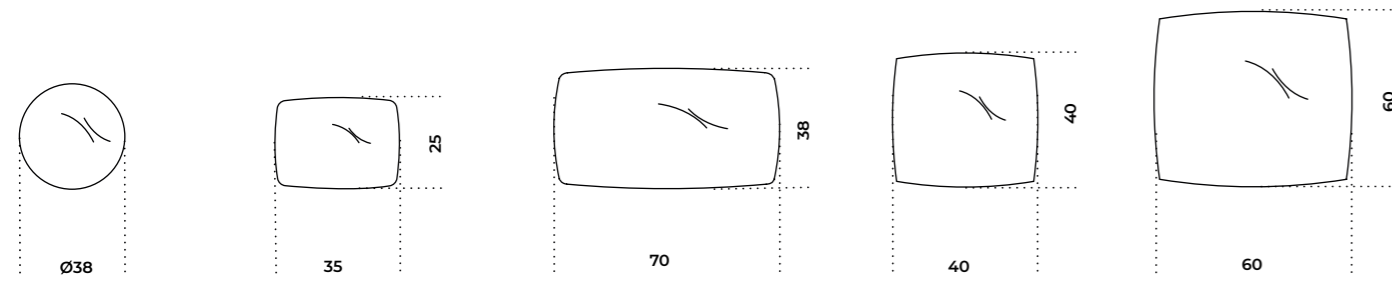

Tic Tac 14 | Studio G&R, 2014

Product information / p. 656

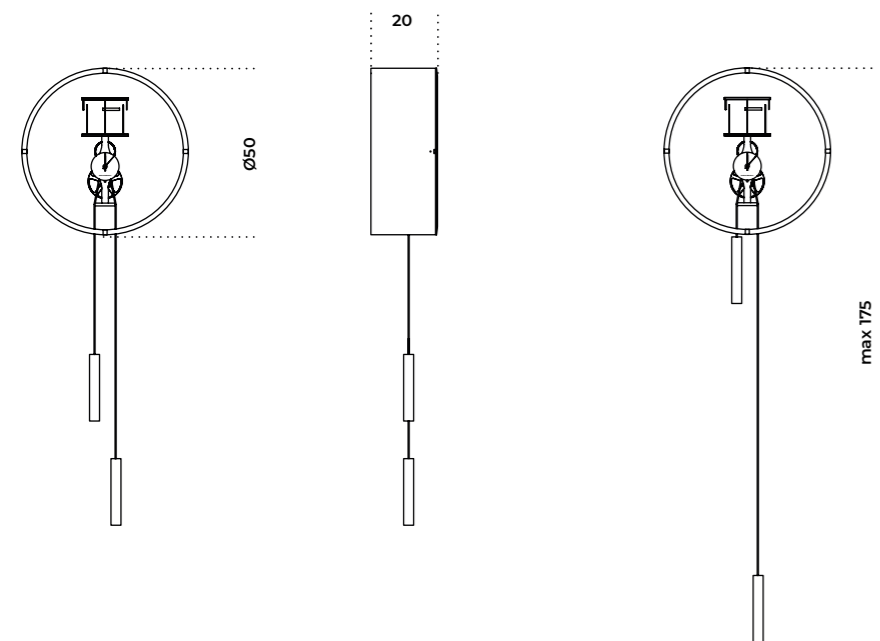

Gallotti&Radice srl
via Matteotti, 17
22072 Cermenate (Como) Italy
T +39 031 777111
info@gallottiradice.it
gallottiradice.it